

DISCRETE THYRISTORS

Phase Control SCR / Inverter Grade SCR

Applications Include:

- Battery Chargers
- Flexible AC Transmissions
- Induction Heating
- Medical Equipment
- Medium Voltage Inverters
- Motor Controls
- Power Supplies
- Traction Inverters
- Transportation
- UPS
- VAR Generators
- Welding

Packages:

- Discrete Discs
- Discrete Studs

TABLE OF CONTENTS

Numbering System	G-2
Product Overview	G-2
Standard Leads.....	G-4
Phase Control SCRs.....	G-5
Inverter Grade SCRs.....	G-8
Outline Drawings.....	G-10

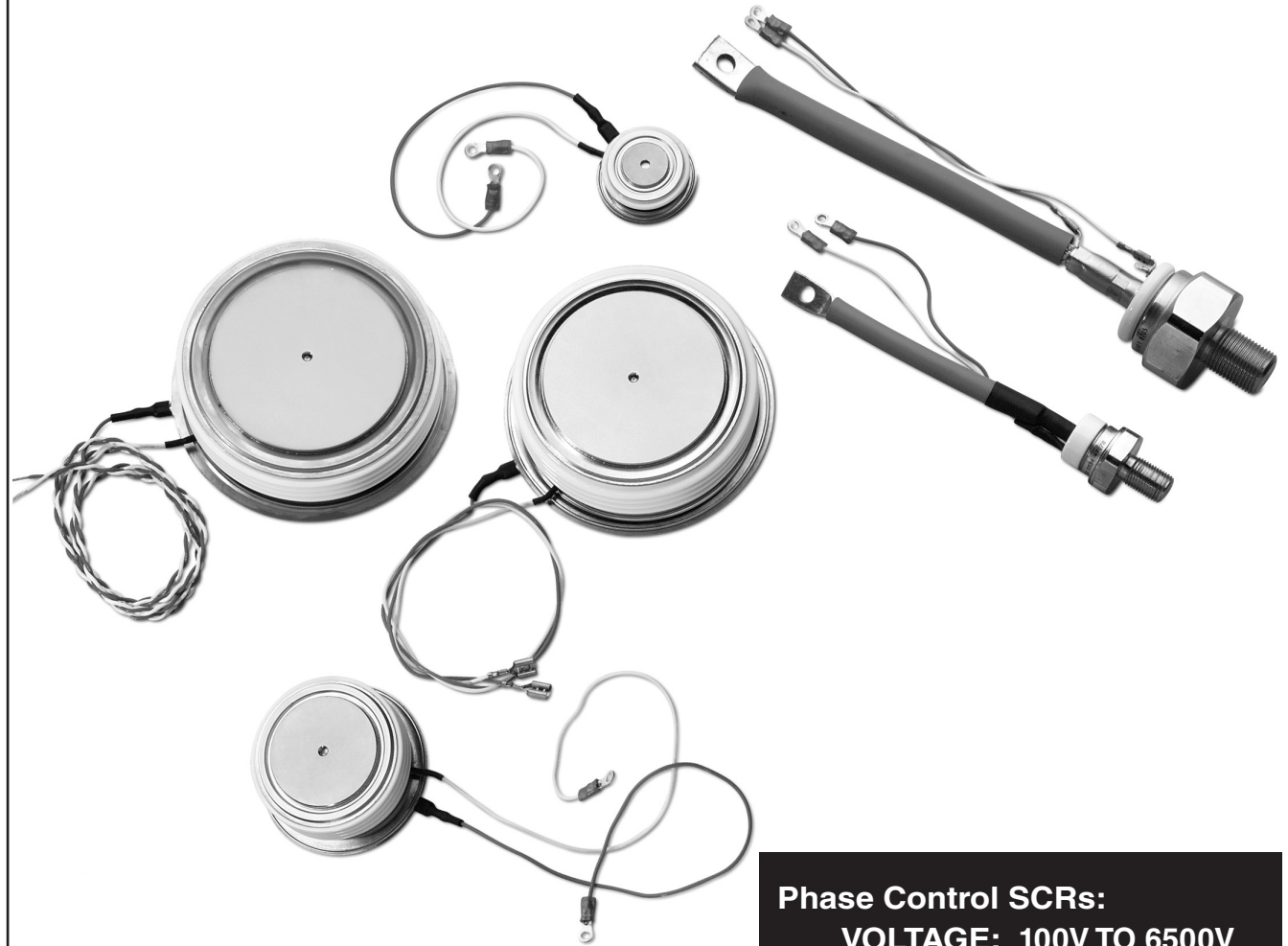

Phase Control SCRs:

VOLTAGE: 100V TO 6500V

CURRENT: 40A TO 5000A

Inverter Grade SCRs:

VOLTAGE: 200V TO 2000V

CURRENT: 40A TO 2100A

Custom
Modules

IGBT
Assemblies

Assemblies

Fast Recovery
Diode Modules

Thyristor &
Diode
Modules

Discrete
Rectifiers

**Discrete
Thyristors**

SiC
Modules

Product Overview

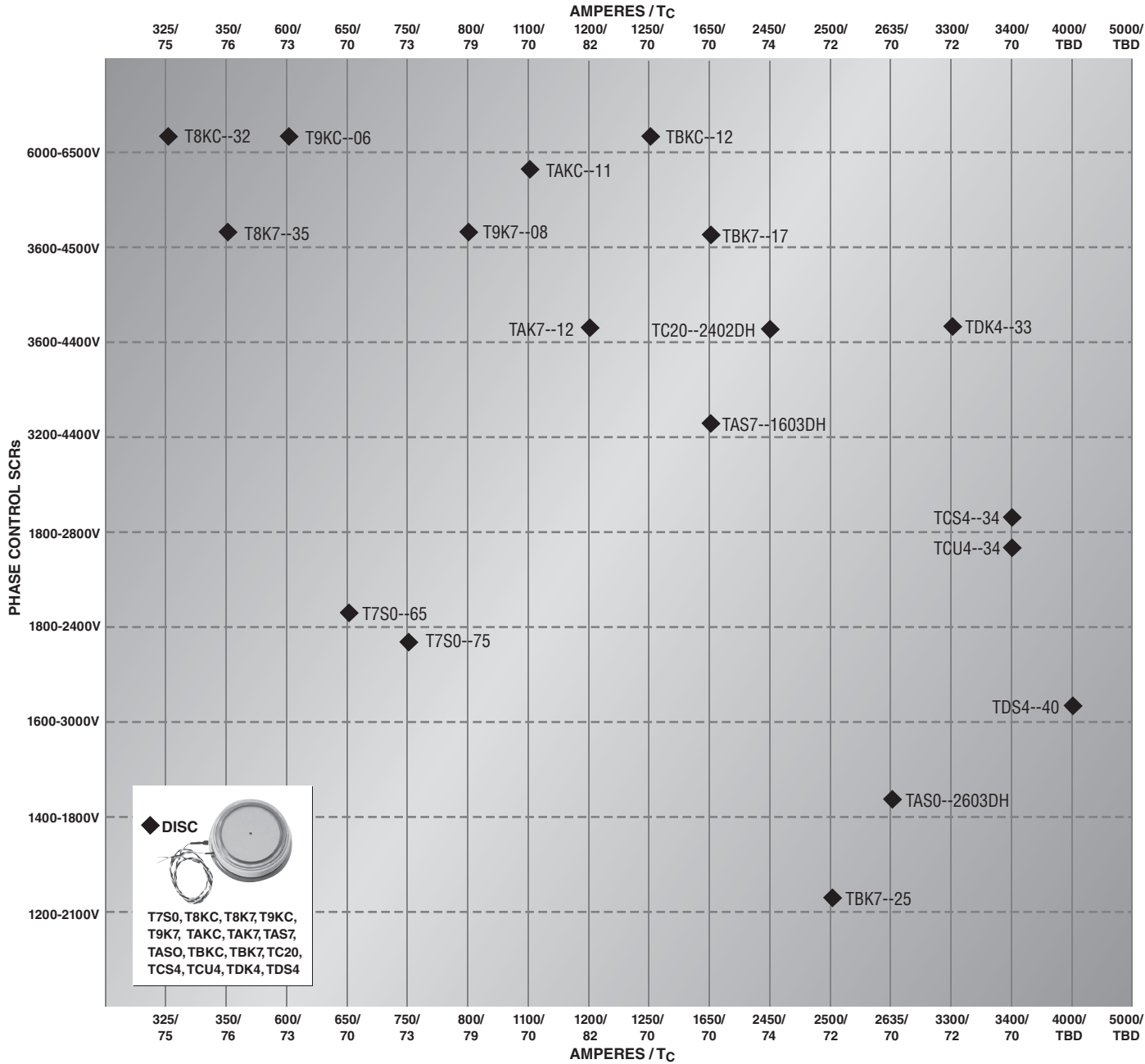

Numbering System

T7S0246504DN is a 650 Ampere, 2400 Volt, Phase Control SCR



T627122064DN is a 200 Ampere, 1200 Volt, Inverter Grade SCR

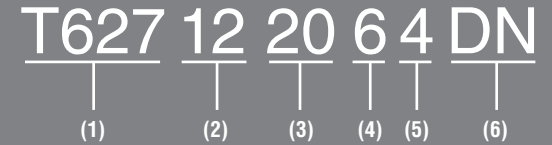

- (1) Type Number
- (2) Voltage Rating (x 100)
- (3) Current Rating:
 - T5 (x 1)
 - T6, T7, T8 (x 10)
 - T9, TA, TB, TC, TD (x 100)

Product Overview

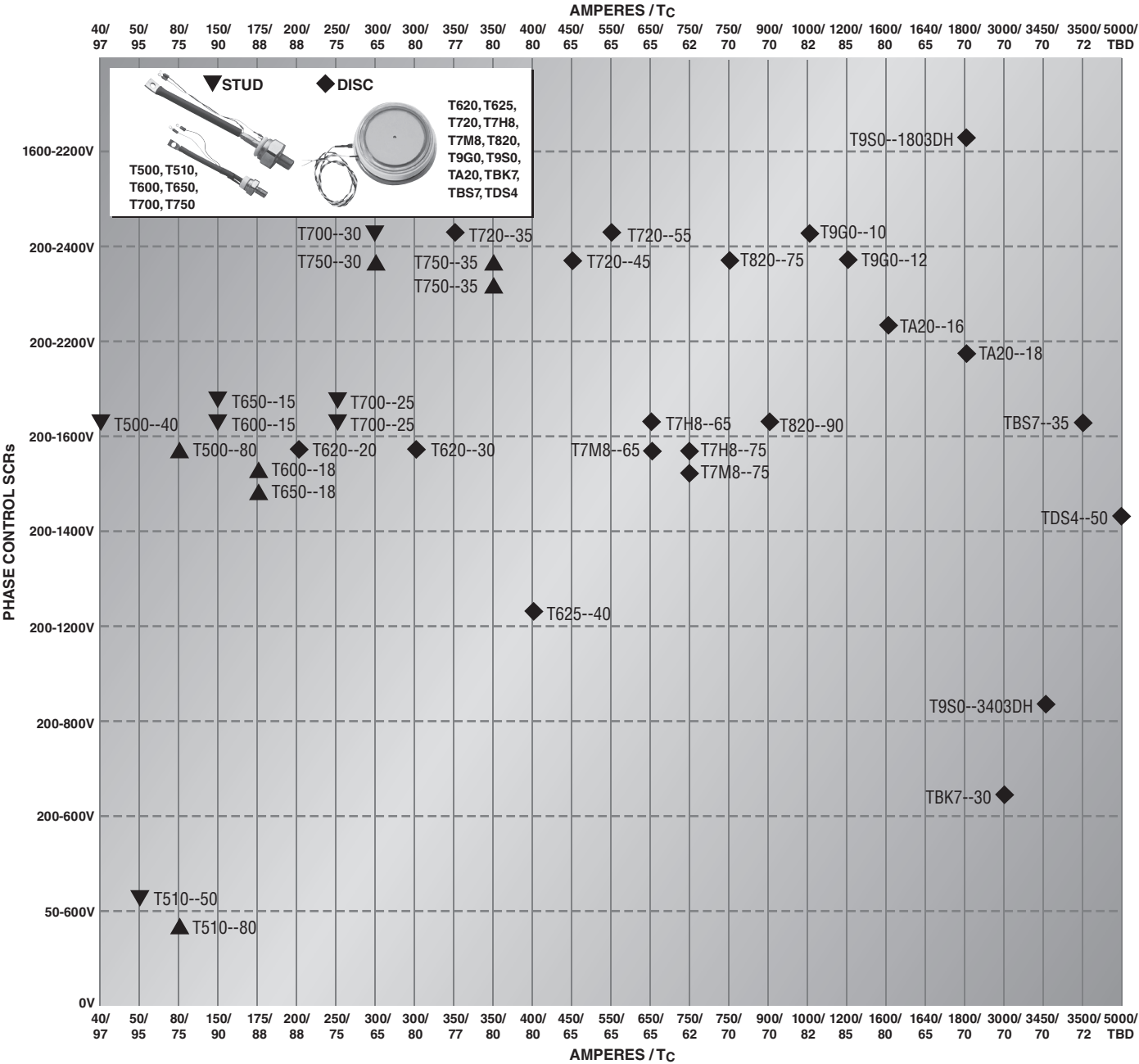

Numbering System

(4) Turn-off Time (T_q) Codes for SCR Part Numbers

Code	Time (μsec)
0	Phase Control
9	8
8	10
7	15
6	20
B	25
5	30
L	35
4	40
3	50
2	60
C	70
1	80
K	100
M	125
N	150
P	175
Q	200
R	250

(5) Maximum Gate Current to Trigger (I_{gt}) Codes for SCR Part Numbers

Code	I _{gt} (mA)
7	70
K	75
6	80
5	100
F	120
4	150
G	180
3	200
H	250
2	300
1	500
X	Not Applicable

(6) Lead Code - Standard Lead Table can be found on page G-4

Product Overview

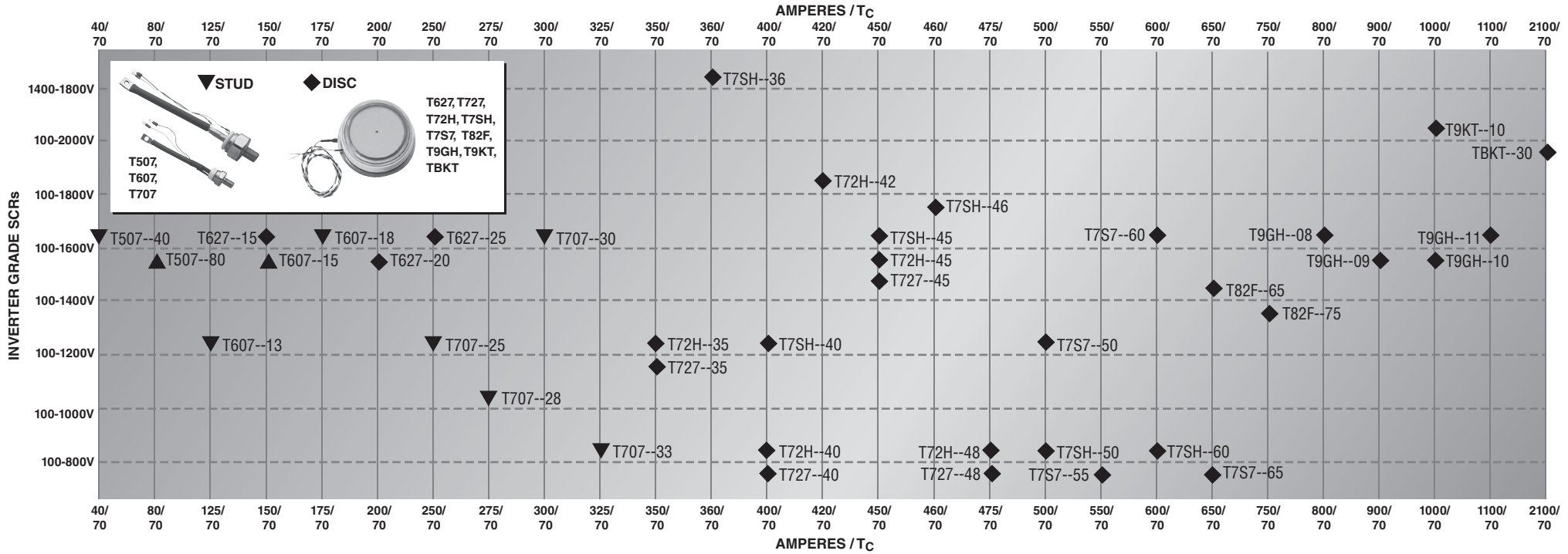

Standard Leads

Device Type	Lead Code	Description
Disc		
Disc	DN	Gate leads: 8" with #6 ring terminals
Disc	DH	Gate leads: 12" with #6 ring terminals
Disc	HE	Gate leads: 20" with #6 ring terminals
Stud		
T5	AQ	Power Lead: 6.04" from seating plane to center of 0.266" diameter hole in terminal lug, Gate leads: 7.34" with #6 ring terminals
T6	BT	Power Lead: 7.85" from seating plane to center of 0.281" diameter hole in terminal lug, Gate leads: 7.86" with #6 ring terminals
T7	BY	Power Lead: 9.66" from seating plane to center of 0.343" diameter hole in terminal lug, Gate leads: 10.03" with #6 ring terminals (Note: High Voltage T7 studs with convoluted seal will have power lead 9.88" from seating plane to center of 0.343" diameter hole in terminal lug, Gate leads: 10.03" with #6 ring terminals)

Phase Control Disc/Hockey Puk SCRs

Type	V_{DRM} / V_{RRM} Volts ($V_{RSM} = V_{RRM} + 100V$)	$I_{T(av)/TC}$ Amperes/°C (180° sin)	$I_{T(RMS)}$ Amperes (180° sin)	EUROPEAN		NORTH AMERICAN		V_{TM}/I_{TM} Volts/Amperes ($T_{j(max)}$)	V_{TO} Volts ($T_{j(max)}$)	R_T mΩ ($T_{j(max)}$)	di/dt Amperes/μsec (Non-Repetitive)	T_q μsec (Typical)	dV/dt^* Volts/μsec	$R_{th(j-c)}$ °C/W	$R_{th(c-s)}$ °C/W	$T_{j(max)}$ °C	Outline Drawings	
				I_{TSM} Amperes (10ms, $T_{j(max)}$), No V_{RRM} Reapplied)	i^2t A ² sec (10ms, $T_{j(max)}$), No V_{RRM} Reapplied)	I_{TSM} Amperes (8.3ms, $T_{j(max)}$), 100% V_{RRM} Reapplied)	i^2t A ² sec (8.3ms, $T_{j(max)}$), 100% V_{RRM} Reapplied)										Number	Page
Up to 1800V																		
T620--2004DN	200 – 1600	200 / 88	315	6,000	180,000	4,000	64,000	1.98 / 500	1.13	1.72	800	100	300	0.08	0.02	125	1	G-10
T620--3004DN	200 – 1600	300 / 80	470	8,250	340,313	5,500	120,000	1.49 / 500	0.99	1.05	800	100	300	0.08	0.02	125	1	G-10
T625--4004DN	200 – 1200	400 / 80	625	7,500	281,250	5,000	100,000	1.1 / 200	0.77	1.24	800	150	300	0.08	0.02	150	1	G-10
T7H8--6504DN	200 – 1600	650 / 65	1,020	13,500	911,250	9,000	338,000	1.38 / 500	1.034	0.629	600	150	300	0.04	0.02	125	2	G-10
T7M8--6504DN	200 – 1600	650 / 65	1,020	13,500	911,250	9,000	338,000	1.38 / 500	1.034	0.629	600	1500	300	0.04	0.02	125	3	G-10
T7H8--7504DN	200 – 1600	750 / 62	1,180	15,750	1.2×10^6	10,500	460,000	1.50 / 1000	0.972	0.482	600	150	300	0.04	0.02	125	2	G-10
T7M8--7504DN	200 – 1600	750 / 62	1,180	15,750	1.2×10^6	10,500	460,000	1.50 / 1000	0.972	0.482	600	1500	300	0.04	0.02	125	3	G-10
T820--9004DH	200 – 1600	900 / 70	1,410	22,500	2.5×10^6	15,000	935,000	1.20 / 1000	0.785	0.351	400	300	300	0.037	0.02	125	5	G-11
TAS0--2603DH	1400 – 1800	2635 / 70	4,139	35,826	6.42×10^6	26,174	2.85×10^6	0.99 / 1500	0.735	0.16	300	550	800	0.01	0.003	125	8	G-12
TBK7--300HHE	200 – 600	3000 / 70	4,710	72,000	25.9×10^6	48,000	9.6×10^6	0.97 / 3000	0.692	0.087	600	400	300	0.012	0.002	125	10	G-13
T9S0--3403DH	200 – 800	3450 / 70	5,419	33,469	5.60×10^6	23,665	5.25×10^6	0.85 / 1500	0.722	8.83×10^6	200	400	600	0.015	0.0025	140	6	G-11
TBS7--350HHE	200 – 1600	3500 / 72	5,600	72,000	25.9×10^6	48,000	9.6×10^6	0.97 / 3000	0.692	0.087	600	400	300	0.010	0.002	125	11	G-13
Up to 2400V																		
T720--3504DN	200 – 2400	350 / 77	550	10,500	551,250	7,000	205,000	1.61 / 500	1.040	1.09	600	150	300	0.06	0.02	125	5	G-11
T720--4504DN	200 – 2400	450 / 65	700	12,600	793,800	8,400	295,000	1.25 / 300	0.93	0.90	600	150	300	0.06	0.02	125	5	G-11
T720--5504DN	200 – 2400	550 / 65	850	15,000	1.1×10^6	10,000	416,000	1.0 / 200	0.99	0.47	600	150	300	0.06	0.02	125	5	G-11
T7S0--6504DN	1800 – 2400	650 / 70	1,020	13,500	911,250	9,000	338,000	1.38 / 500	1.00	0.701	600	150	300	0.035	0.02	125	4	G-11
T7S0--7504DN	1800 – 2400	750 / 73	1,180	15,750	1.2×10^6	10,500	460,000	1.50 / 1000	0.972	0.482	600	150	300	0.035	0.02	125	4	G-11
T820--7504DH	200 – 2400	750 / 70	1,175	18,000	1.6×10^6	12,000	600,000	1.52 / 1000	0.927	0.495	400	200	300	0.037	0.020	125	5	G-11
T9G0--1003DH	200 – 2400	1000 / 82	1,590	25,500	3.2×10^6	17,000	1.2×10^6	1.0 / 300	0.904	0.491	600	250	1000	0.023	0.006	125	7	G-12
T9G0--1203DH	200 – 2400	1200 / 85	1,880	40,500	8.2×10^6	27,000	3.0×10^6	0.97 / 1000	0.606	0.268	300	350	300	0.023	0.008	125	7	G-12
TA20--1603DH	200 – 2200	1600 / 80	2,500	44,250	9.7×10^6	29,500	3.63×10^6	1.12 / 1000	0.891	0.215	400	250	300	0.015	0.007	125	9	G-12
T9S0--1803DH	1600 – 2200	1800 / 70	2,827	19,422	1.89×10^6	13,735	1.77×10^6	1.38 / 1500	1.025	0.23	200	400	1000	0.015	0.0025	125	6	G-11
TA20--1803DH	200 – 2200	1800 / 85	2,820	60,000	18.0×10^6	40,000	6.67×10^6	0.89 / 1000	0.719	0.167	400	250	300	0.015	0.007	125	9	G-12
TBK7--250HHE	1200 – 2100	2500 / 72	3,925	67,500	22.7×10^6	45,000	8.5×10^6	1.35 / 2000	0.95	0.123	600	250	500	0.012	0.002	125	10	G-13

*Please consult factory for critical dv/dt requirements to 1000Volts/μsec

Phase Control Disc/Hockey Puk SCRs (Continued)

Type	V_{DRM} / V_{RRM} Volts ($V_{RSM} = V_{RRM} + 100V$)	$I_{T(av)/TC}$ Amperes/°C (180° sin)	$I_T(RMS)$ Amperes (180° sin)	EUROPEAN		NORTH AMERICAN		V_{TM}/I_{TM} Volts/Amperes ($T_{j(max)}$)	V_{TO} Volts ($T_{j(max)}$)	R_T mΩ ($T_{j(max)}$)	di/dt Amperes/μsec (Non-Repetitive)	T_q μsec (Typical)	dV/dt Volts/μsec	$R_{th(j-c)}$ °C/W	$R_{th(c-s)}$ °C/W	$T_{j(max)}$ °C	Outline Drawings	
				I_{TSM} Amperes (10ms, $T_{j(max)}$), No V_{RRM} Reapplied)	i^2t A ² sec (10ms, $T_{j(max)}$), No V_{RRM} Reapplied)	I_{TSM} Amperes (8.3ms, $T_{j(max)}$), 100% V_{RRM} Reapplied)	i^2t A ² sec (8.3ms, $T_{j(max)}$), 100% V_{RRM} Reapplied)										Number	Page
Up to 4500V																		
T8K7--3503DH	3600 – 4500	350 / 76	550	8,250	340,313	5,500	100,000	3.50 / 1000	1.562	2.141	500	250	1000	0.040	0.020	125	5	G-11
T9K7--0802DH	3600 – 4500	800 / 79	1,250	13,500	911,250	9,000	337,500	1.79 / 1000	1.213	0.602	200	500	800	0.023	0.008	125	7	G-12
TAK7--1202DH	3600 – 4400	1200 / 82	1,700	60,000	18.0 x 10 ⁶	40,000	6.67 x 10 ⁶	1.90 / 1500	1.262	0.397	400	500	1000	0.015	0.007	125	9	G-12
TAS7--1603DH	3200 – 4400	1650 / 70	2,592	20,742	2.15 x 10 ⁶	15,154	956,845	2.00 / 1500	0.881	0.374	300	550	800	0.01	0.003	125	8	G-12
TBK7--1702HHE	3600 – 4500	1650 / 70	2,590	39,000	7.6 x 10 ⁶	26,000	2.75 x 10 ⁶	1.85 / 2000	1.033	0.358	600	400	1000	0.012	0.002	125	10	G-13
TC20--2402DH	3600 – 4400	2450 / 74	3848	28,284	4.00 x 10 ⁶	20,664	1.78 x 10 ⁶	1.80 / 3000	0.99	0.271	300	500	400	0.009	0.003	125	12	G-13
TDK4--3302DH	3600 – 4400	3300 / 72	5,184	47,140	1.11 x 10 ⁷	31,427	1.04 x 10 ⁷	1.60 / 3000	0.991	0.196	300	400	2000	0.005	0.001	125	13	G-14
TCS4--340HDH	1800 – 2800	3400 / 70	5,341	56,568	1.60 x 10 ⁷	37,712	1.50 x 10 ⁷	1.34 / 3000	0.915	0.14	600	400	1000	0.007	0.001	125	14	G-14
TCU4--340HDH	1800 – 2800	3400 / 70	5,341	75,424	2.84 x 10 ⁷	53,330	1.19 x 10 ⁷	1.35 / 3000	0.978	0.112	400	400	1000	0.008	0.002	125	16	G-15
TDS4--340HDH	3000 - 3400	3475 / 70	5,459	67,200	2.26 x 10 ⁷	TBD	TBD	1.50 / 4000	0.914	0.145	600	600	800	0.007	0.0015	125	15	G-14
TDS4--50	200 – 1400	5000	7,854	TBD	TBD	TBD	TBD	TBD	TBD	TBD	TBD	TBD	TBD	0.007	0.0015	125	15	G-14
Up to 6500V																		
T8KC--3203DH	6000 – 6500	325 / 75	511	4,243	9 x 10 ⁴	2,950	36,260	4.40 / 1000	1.17	3.26	200	450	1000	0.038	0.007	125	5	G-11
T9KC--0603DH	6000 – 6500	600 / 73	942	7,307	2.67 x 10 ⁵	5,040	105,840	3.70 / 1500	1.32	1.58	300	600	1000	0.023	0.006	125	7	G-12
TAKC--1103DH	6000 – 6500	1100 / 70	1728	11,314	6.40 x 10 ⁵	8,266	2.84 x 10 ⁵	2.80 / 2000	1.06	0.84	200	650	1000	0.13	0.0035	125	9	G-12
TBKC--1203DH	6000 – 6500	1250 / 70	1,963	20,742	2.15 x 10 ⁶	14,300	852,042	2.70 / 2000	1.153	0.744	200	800	1000	0.011	0.001	125	10	G-13

Phase Control Stud SCRs

Type	V_{DRM} / V_{RRM} Volts ($V_{RSM} = V_{RRM} + 100V$)	$I_{T(av)}/T_C$ Amperes/°C (180° sin)	$I_T(RMS)$ Amperes (180° sin)	EUROPEAN		NORTH AMERICAN		V_{TM}/I_{TM} Volts/Amperes ($T_{j(max)}$)	V_{T0} Volts ($T_{j(max)}$)	R_T mΩ ($T_{j(max)}$)	di/dt Amperes/μsec (Non-Repetitive)	T_q μsec (Typical)	dV/dt* Volts/μsec	$R_{th(j-c)}$ °C/W	$R_{th(c-s)}$ °C/W	$T_{j(max)}$ °C	Outline Drawings	
				I_{TSM} Amperes (10ms, $T_{j(max)}$), No V_{RRM} Reapplied)	i^2t A ² sec (10ms, $T_{j(max)}$), No V_{RRM} Reapplied)	i_{TSM} Amperes (8.3ms, $T_{j(max)}$), 100% V_{RRM} Reapplied)	i^2t A ² sec (8.3ms, $T_{j(max)}$), 100% V_{RRM} Reapplied)										Number	Page
Up to 1600V																		
T500--4004AQ	200 – 1600	40 / 97	63	1,800	16,200	1,200	6,000	2.02 / 100	0.91	11.85	800	100	300	0.28	0.12	125	17	G-15
T510--5004AQ	50 – 600	50 / 95	80	1,800	16,200	1,200	6,000	1.95 / 100	0.79	12.54	100	100	300	0.28	0.12	125	18	G-15
T500--8004AQ	200 – 1600	80 / 75	125	2,700	36,450	1,800	13,500	1.43 / 100	0.99	3.57	800	100	300	0.28	0.12	125	17	G-15
T510--8004AQ	50 – 600	80 / 75	125	2,400	28,800	1,600	10,700	1.36 / 100	0.85	4.71	100	100	300	0.28	0.12	125	18	G-15
T600--1504BT	200 – 1600	150 / 90	235	6,000	180,000	4,000	66,000	1.41 / 200	1.07	1.46	800	100	300	0.13	0.075	125	19	G-16
T650--1504BT	200 – 1600	150 / 90	235	6,000	180,000	4,000	66,000	1.41 / 200	1.07	1.46	800	100	300	0.13	0.075	125	20	G-16
T600--1804BT	200 – 1600	175 / 88	275	8,250	340,313	5,500	120,000	1.20 / 200	0.90	1.26	800	100	300	0.13	0.075	125	19	G-16
T650--1804BT	200 – 1600	175 / 88	275	8,250	340,313	5,500	120,000	1.20 / 200	0.90	1.26	800	100	300	0.13	0.075	125	20	G-16
T700--2504BY	200 – 1600	250 / 75	400	10,500	551,250	7,000	205,000	1.16 / 100	1.06	1.01	800	150	300	0.10	0.05	125	21	G-16
T750--2504BY	200 – 1600	250 / 75	400	10,500	551,250	7,000	205,000	1.16 / 100	1.06	1.01	800	150	300	0.10	0.05	125	22	G-17
Up to 2400V																		
T700--3004BY	200 – 2400	300 / 65	470	12,600	793,800	8,400	295,000	0.98 / 100	0.88	0.92	800	150	300	0.10	0.05	125	21	G-16
T750--3005BY	200 – 2400	300 / 65	470	12,600	793,800	8,400	295,000	0.98 / 100	0.88	0.92	800	150	300	0.10	0.05	125	22	G-17
T700--3504BY	200 – 2400	350 / 80	550	15,000	1.1 x 10 ⁶	10,000	416,000	0.98 / 200	0.83	0.61	800	150	300	0.10	0.05	125	21	G-16
T750--3504BY	200 – 2400	350 / 80	550	15,000	1.1 x 10 ⁶	10,000	416,000	0.98 / 200	0.83	0.61	800	150	300	0.10	0.05	125	22	G-17

*Please consult factory for critical dv/dt requirements to 1000Volts/μsec

Inverter Grade Disc/Hockey Puk SCRs

Type	V_{DRM} / V_{RRM} Volts ($V_{RSM} = V_{RRM} + 100V$)	$I_{(av)TC}$ Amperes/°C ($180^\circ \sin$)	$I_{T(RMS)}$ Amperes ($180^\circ \sin$)	EUROPEAN		NORTH AMERICAN		V_{TM}/I_{TM} Volts/Amperes ($T_{j(max)}$)	V_{TO} Volts ($T_{j(max)}$)	R_T mΩ ($T_{j(max)}$)	di/dt Amperes/μsec (Non-Repetitive)	T_q μsec (Typical)	dV/dt* Volts/μsec	$R_{th(j-c)}$ °C/W	$R_{th(c-s)}$ °C/W	$T_{j(max)}$ °C	Outline Drawings	
				I_{TSM} Amperes (10ms, $T_{j(max)}$). No V_{RRM} Reapplied)	i^2t A ² sec (10ms, $T_{j(max)}$). No V_{RRM} Reapplied)	i_{TSM} Amperes (8.3ms, $T_{j(max)}$). No V_{RRM} Reapplied)	i^2t A ² sec (8.3ms, $T_{j(max)}$). No V_{RRM} Reapplied)										Number	Page
Up to 1200V																		
T727--35*4DN	100 – 1200	350 / 70	550	10,500	551,250	7,000	205,000	1.70 / 600	1.27	0.71	800	15 – 60	300	0.06	0.02	125	5	G-11
T72H--35*4DN	100 – 1200	350 / 70	550	10,500	551,250	7,000	205,000	2.09 / 500	1.77	0.68	1200	10 – 50	300	0.06	0.02	125	5	G-11
T727--40*4DN	100 – 800	400 / 70	625	10,500	551,250	7,000	205,000	1.55 / 500	1.40	0.34	800	10 – 50	300	0.06	0.02	125	5	G-11
T72H--40*4DN	100 – 800	400 / 70	625	10,500	551,250	7,000	205,000	1.49 / 500	1.19	0.55	1200	10 – 20	300	0.06	0.02	125	5	G-11
T7SH--40*4DN	100 – 1200	400 / 70	700	12,000	720,000	8,000	267,000	2.11 / 500	1.76	0.73	1200	10 – 50	300	0.045	0.02	125	4	G-11
T727--48*4DN	100 – 800	475 / 70	750	12,000	720,000	8,000	265,000	1.37 / 500	1.35	0.44	800	15 – 50	300	0.06	0.02	125	5	G-11
T72H--48*4DN	100 – 800	475 / 70	750	12,000	720,000	8,000	265,000	1.37 / 500	1.14	0.44	1200	20 – 40	300	0.06	0.02	125	5	G-11
T7S7--50*4DN	100 – 1200	500 / 70	786	12,000	720,000	8,000	267,000	1.62 / 500	1.29	0.65	800	15 – 60	300	0.035	0.02	125	2	G-10
T7SH--50*4DN	100 – 800	500 / 70	780	12,750	812,813	8,500	301,000	1.44 / 500	1.18	0.43	1200	10 – 20	300	0.045	0.02	125	4	G-11
T7S7--55*4DN	100 – 800	550 / 70	864	12,750	812,813	8,500	301,000	1.53 / 500	1.36	0.34	800	10 – 50	300	0.035	0.02	125	2	G-10
T7SH--60*4DN	100 – 800	600 / 70	950	13,500	911,250	9,000	338,000	1.04 / 500	0.90	0.28	1200	20 – 40	300	0.045	0.02	125	4	G-11
T7S7--65*4DN	100 – 800	650 / 70	1,026	14,250	1.0 x 10 ⁶	9,500	376,000	1.36 / 500	1.15	0.40	800	10 – 50	300	0.035	0.02	125	2	G-10
Up to 1600V																		
T627--15*4DN	100 – 1600	150 / 70	235	5,250	137,813	3,500	50,000	1.64 / 100	1.41	1.80	800	10 – 50	300	0.08	0.02	125	1	G-10
T627--20*4DN	100 – 1600	200 / 70	315	6,000	180,000	4,000	65,000	1.48 / 100	1.27	1.50	800	10 – 50	300	0.08	0.02	125	1	G-10
T627--25*4DN	100 – 1600	250 / 70	400	6,750	227,813	4,500	84,000	1.38 / 100	1.22	1.12	800	10 – 50	300	0.08	0.02	125	1	G-10
T727--45*4DN	100 – 1600	450 / 70	700	12,000	720,000	8,000	265,000	1.42 / 500	1.14	0.57	800	15 – 60	300	0.06	0.02	125	5	G-11
T72H--45*4DN	100 – 1600	450 / 70	700	11,250	632,813	7,500	234,000	1.55 / 500	1.08	0.79	1200	15 – 50	300	0.06	0.02	125	5	G-11
T7SH--45*4DN	100 – 1600	450 / 70	700	12,750	812,813	8,500	301,000	1.80 / 800	1.05	0.96	1200	15 – 50	300	0.045	0.02	125	4	G-11
T7S7--60*4DN	100 – 1600	600 / 70	943	13,500	911,250	9,000	338,000	1.44 / 500	1.16	0.56	800	15 – 60	300	0.035	0.02	125	2	G-10
T82F--65*3DN	100 – 1400	650 / 70	1,000	12,750	812,813	8,500	300,000	1.75 / 1000	1.46	0.30	1000	10 – 50	400	0.037	0.02	125	5	G-11
T82F--75*3DN	100 – 1400	750 / 70	1,180	15,000	1.1 x 10 ⁶	10,000	416,000	1.52 / 1000	1.21	0.29	1200	25 – 60	400	0.037	0.02	125	5	G-11
T9GH--08*2DH	100 – 1600	800 / 70	1,250	15,000	1.1 x 10 ⁶	10,000	416,000	1.98 / 1000	1.58	0.41	1000	20 – 100	400	0.023	0.075	125	7	G-12
T9GH--09*2DH	100 – 1600	900 / 70	1,400	19,500	1.9 x 10 ⁶	13,000	700,000	1.73 / 1000	1.32	0.40	1000	20 – 100	400	0.023	0.075	125	7	G-12
T9GH--10*2DH	100 – 1600	1000 / 70	1,570	22,500	2.5 x 10 ⁶	15,000	937,000	1.70 / 1000	1.29	0.40	1000	20 – 60	400	0.023	0.075	125	7	G-12
T9GH--11*2DH	100 – 1600	1100 / 70	1,725	25,500	3.2 x 10 ⁶	17,000	1.2 x 10 ⁶	1.39 / 1000	1.12	0.25	1000	40 – 60	100	0.023	0.075	125	7	G-12
Up to 2000V																		
T7SH--36*4DN	1400 – 1800	360 / 70	565	9,000	405,000	6,000	297,000	2.19 / 500	1.81	0.81	800	40 – 60	300	0.045	0.02	125	4	G-11
T72H--42*4DN	100 – 1800	420 / 70	650	10,200	520,200	6,800	205,000	1.67 / 700	1.27	0.57	1200	15 – 100	300	0.06	0.02	125	5	G-11
T7SH--46*4DN	100 – 1800	460 / 70	720	10,200	520,200	6,800	301,000	1.47 / 500	1.22	0.58	800	15 – 70	300	0.045	0.02	125	4	G-11
T9KT--10J2DE	100 – 2000	1000 / 70	1,570	30,000	4.5 x 10 ⁶	20,000	1.6 x 10 ⁶	1.50 / 1000	1.13	0.35	800	55	500	0.023	0.075	125	7	G-12
TBKT--3022DH	100 – 2000	2100 / 70	3,300	57,000	16.2 x 10 ⁶	38,000	6.0 x 10 ⁶	1.55 / 1000	1.27	0.26	800	80	500	0.012	0.002	125	10	G-13

*Please consult factory for critical dv/dt requirements to 1000Volts/μsec

Inverter Grade Stud SCRs

Type	V _{DRM} / V _{RRM} Volts (V _{RSM} = V _{RRM} + 100V)	I _{T(av)} /T _C Amperes/°C (180° sin)	I _{T(RMS)} Amperes (180° sin)	EUROPEAN		NORTH AMERICAN		V _{TM} /I _{TM} Volts/Amperes (T _{j(max)})	V _{T0} Volts (T _{j(max)})	R _T mΩ (T _{j(max)})	di/dt Amperes/μsec (Non-Repetitive)	T _q μsec (Typical)	dV/dt* Volts/μsec	R _{th(j-c)} °C/W	R _{th(c-s)} °C/W	T _{j(max)} °C	Outline Drawings	
				I _{TSM} Amperes (10ms, T _{j(max)}), No V _{RRM} Reapplied)	i ² t A ² sec (10ms, T _{j(max)}), No V _{RRM} Reapplied)	I _{TSM} Amperes (8.3ms, T _{j(max)}), No V _{RRM} Reapplied)	i ² t A ² sec (8.3ms, T _{j(max)}), No V _{RRM} Reapplied)										Number	Page
Up to 1200V																		
T607--13*4BT	100 – 1200	125 / 70	200	5,250	137,813	3,500	50,000	1.63 / 100	1.37	2.10	800	10 – 50	300	0.13	0.08	125	19	G-16
T707--25*4BY	100 – 1200	250 / 70	400	10,500	551,250	7,000	205,000	1.46 / 500	1.29	0.43	800	25 – 60	300	0.10	0.05	125	21	G-16
T707--28*4BY	100 – 1000	275 / 70	430	10,500	551,250	7,000	205,000	1.58 / 700	1.34	0.33	800	10 – 50	300	0.10	0.05	125	21	G-16
Up to 1600V																		
T507--40*4AQ	100 – 1600	40 / 70	63	1,500	11,250	1,000	4,000	2.36 / 100	1.00	14.81	800	10 – 50	200	0.28	0.12	125	17	G-15
T507--80*4AQ	100 – 1600	80 / 70	125	2,100	22,050	1,400	8,150	1.88 / 100	0.95	9.87	800	10 – 50	200	0.28	0.12	125	17	G-15
T607--15*4BT	100 – 1600	150 / 70	235	6,000	180,000	4,000	65,000	1.47 / 100	1.25	1.67	800	10 – 50	300	0.13	0.08	125	19	G-16
T607--18*4BT	100 – 1600	175 / 70	275	6,750	227,813	4,500	84,000	1.28 / 100	1.13	1.23	800	10 – 50	300	0.13	0.08	125	19	G-16
T707--30*4BY	100 – 1600	300 / 70	475	12,000	720,000	8,000	265,000	1.45 / 800	1.05	0.53	800	25 – 60	300	0.10	0.05	125	21	G-16
T707--33*4BY	100 – 800	325 / 70	500	12,000	720,000	8,000	265,000	1.52 / 1000	1.17	0.32	800	10 – 50	300	0.10	0.05	125	21	G-16

*Please consult factory for critical dv/dt requirements to 1000Volts/μsec

1

T620, T625, T627

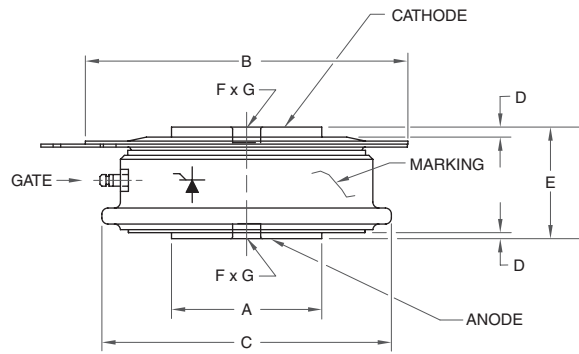

Dim.	Inches	Millimeters
A	0.752 Max.	19.1 Max.
B	1.6575 Dia.	42.1 Dia.
C	1.461 Dia.	37.1 Dia.
D	0.0197 Min.	0.5 Min.

Dim.	Inches	Millimeters
E	0.606 Max.	14.4 Max.
F	0.142 Dia.	3.6 Dia.
G	0.079 Deep	2.0 Deep

2

T7H8, T7S7

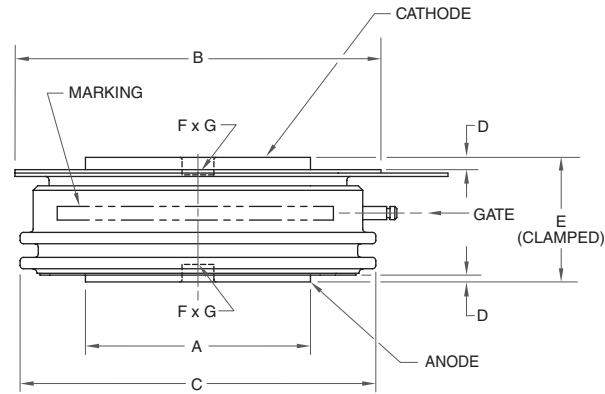

Dim.	Inches	Millimeters
A	0.996 Dia.	25.3 Dia.
B	1.6496 Dia.	41.9 Dia.
C	1.5866 Dia.	40.3 Dia.
D	0.028 Min.	0.7 Min.

Dim.	Inches	Millimeters
E	0.606 Max.	15.4 Max.
F	0.142 Dia.	3.6 Dia.
G	0.0787 Deep	2.0 Deep

3

T7M8

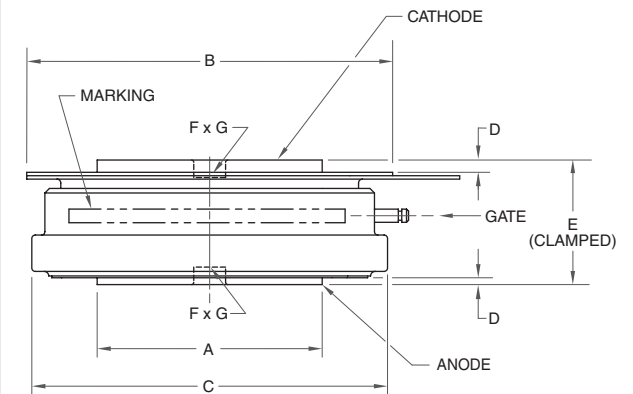

Dim.	Inches	Millimeters
A	0.996 Dia.	25.3 Dia.
B	1.6496 Dia.	41.9 Dia.
C	1.5866 Dia.	40.3 Dia.
D	0.028 Min.	0.7 Min.

Dim.	Inches	Millimeters
E	0.606 Max.	15.4 Max.
F	0.142 Dia.	3.6 Dia.
G	0.0787 Deep	2.0 Deep

4 T7SH, T7SO

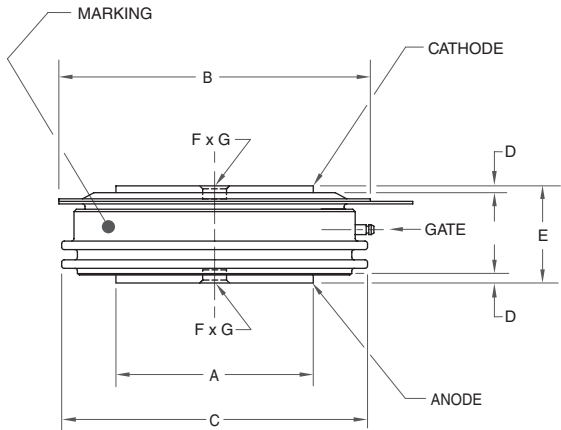

Dim.	Inches	Millimeters
A	1.180 Dia.	29.97 Dia.
B	1.90 Dia.	48.26 Dia.
C	1.850 Dia.	46.99 Dia.
D	0.025 Min.	0.64 Min.

Dim.	Inches	Millimeters
E	0.605 Max.	15.37 Max.
F	0.145 Dia.	3.68 Dia.
G	0.082 Deep	2.08 Deep

5 T720, T72H, T727, T8KC, T8K7, T82F, T820

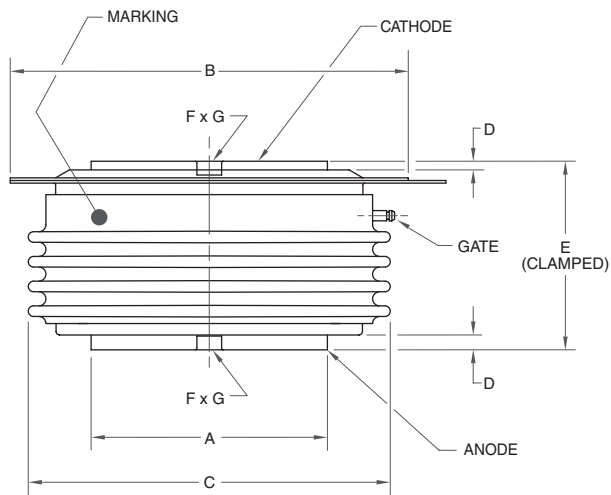

Dim.	Inches	Millimeters
A	1.34 Dia.	34.0 Dia.
B	2.28 Dia.	57.9 Dia.
C	2.05 Dia.	52.1 Dia.
D	0.03 Min.	0.76 Min.

Dim.	Inches	Millimeters
E	1.060 Max.	26.92 Max.
F	0.140 Dia.	3.56 Dia.
G	0.078 Deep	1.98 Deep

6 T9SO

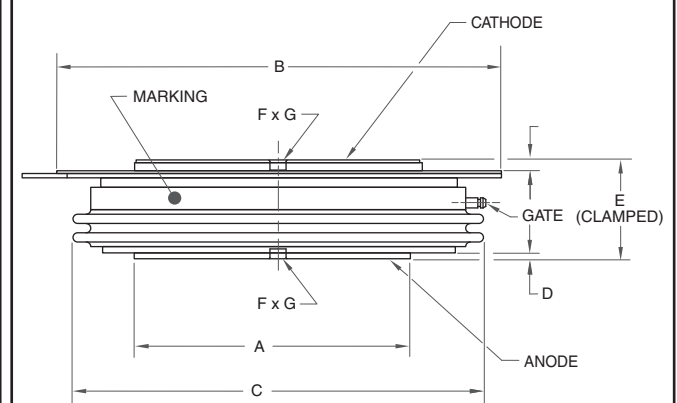

Dim.	Inches	Millimeters
A	1.85 Dia.	47.0 Dia.
B	2.91 Dia.	74.0 Dia.
C	2.64 Dia.	67.0 Dia.
D	0.028 Min.	0.7 Min.

Dim.	Inches	Millimeters
E	0.65 Max.	16.5 Max.
F	0.14 Dia.	3.5 Dia.
G	0.0787 Deep	2.0 Deep

7 T9GH, T9GO, T9KC, T9KT, T9K7

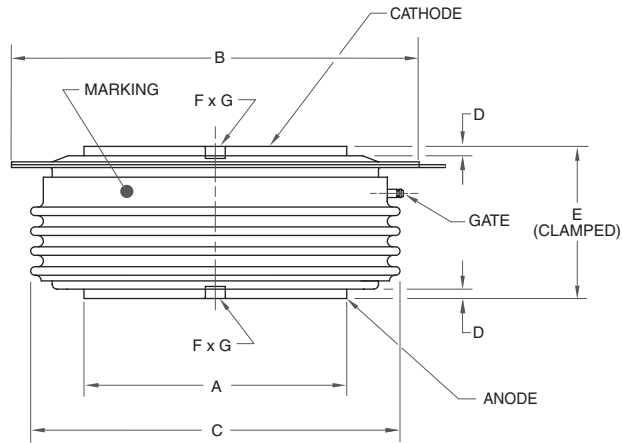

Dim.	Inches	Millimeters	Dim.	Inches	Millimeters
A	1.858 Dia.	47.2 Dia.	E	1.091 Max.	27.7 Max.
B	2.902 Dia.	73.7 Dia.	F	0.142 Dia.	3.6 Dia.
C	2.642 Dia.	67.1 Dia.	G	0.0787 Deep	2.0 Deep
D	0.028 Min.	0.7 Min.			

8 TAS7, TAS0

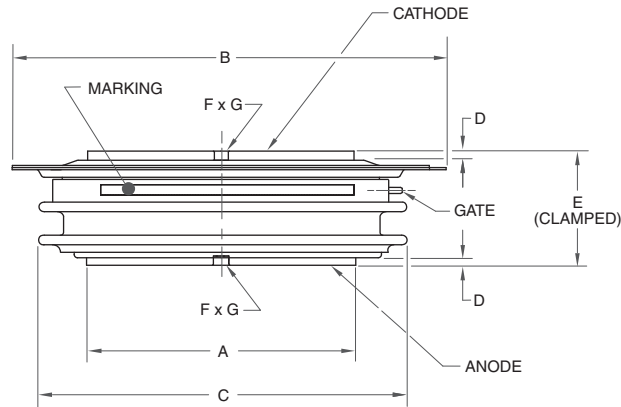

Dim.	Inches	Millimeters	Dim.	Inches	Millimeters
A	2.480 Dia.	63.0 Dia.	E	1.03 Max.	26.162 Max.
B	3.937 Dia.	100.0 Dia.	F	0.14 Dia.	3.556 Dia.
C	3.551 Dia.	90.2 Dia.	G	0.0787 Deep	2.0 Deep
D	0.028 Min.	0.7 Min.			

9 TAKC, TAK7, TA20

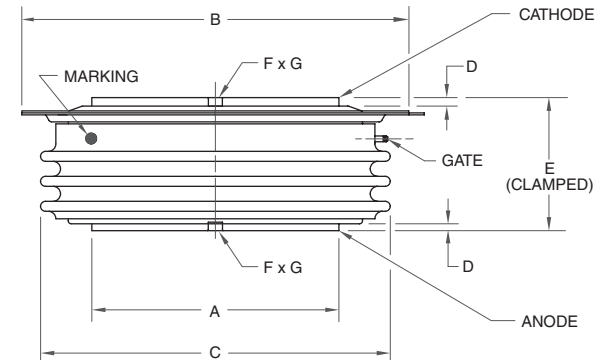

Dim.	Inches	Millimeters	Dim.	Inches	Millimeters
A	2.480 Dia.	63.0 Dia.	E	1.362 Max.	34.6 Max.
B	3.937 Dia.	100.0 Dia.	F	0.142 Dia.	3.6 Dia.
C	3.551 Dia.	90.2 Dia.	G	0.0787 Deep	2.0 Deep
D	0.028 Min.	0.7 Min.			

10 TBKC, TBKT, TBK7

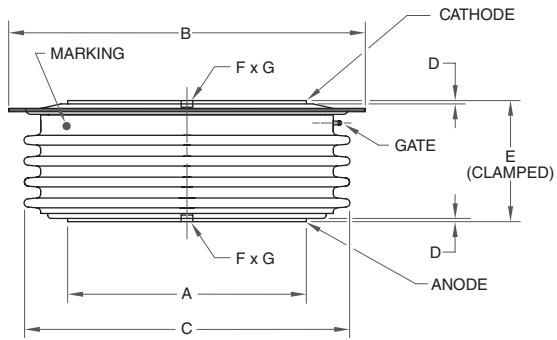

Dim.	Inches	Millimeters
A	2.882 Dia.	73.2 Dia.
B	4.36 Dia.	110.7 Dia.
C	3.961 Dia.	100.6 Dia.
D	0.028 Min.	0.7 Min.

Dim.	Inches	Millimeters
E	1.5 Max.	38.1 Max.
F	0.142 Dia.	3.6 Dia.
G	0.0787 Deep	2.0 Deep

11 TBS7

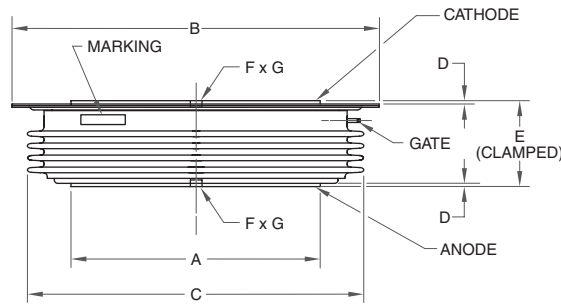

Dim.	Inches	Millimeters
A	2.88 Dia.	73.2 Dia.
B	4.36 Dia.	110.7 Dia.
C	3.95 Dia.	100.3 Dia.
D	0.03 Min.	0.76 Min.

Dim.	Inches	Millimeters
E	1.05 Max.	26.67 Max.
F	0.14 Dia.	3.56 Dia.
G	0.08 Deep	2.03 Deep

12 TC20

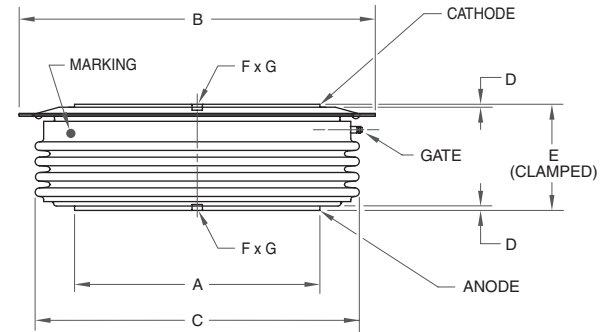

Dim.	Inches	Millimeters
A	3.11 Dia.	84.1 Dia.
B	4.8898 Dia.	124.2 Dia.
C	4.37 Dia.	111.0 Dia.
D	0.028 Min.	0.7 Min.

Dim.	Inches	Millimeters
E	1.5 Max.	38.1 Max.
F	0.142 Dia.	3.6 Dia.
G	0.0787 Deep	2.0 Deep

13 TDK4

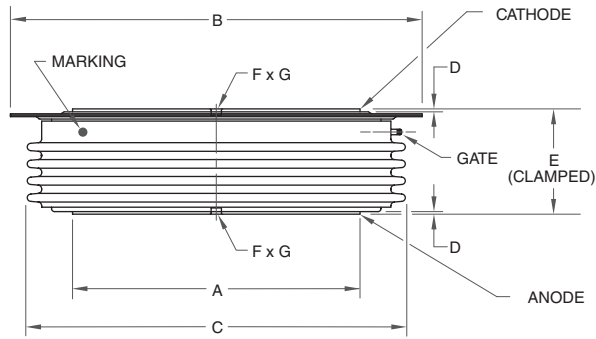

Dim.	Inches	Millimeters
A	3.913 Dia.	99.4 Dia.
B	5.661 Dia.	143.8 Dia.
C	5.181 Dia.	131.6 Dia.
D	0.028 Min.	0.7 Min.

Dim.	Inches	Millimeters
E	1.5 Max.	38.1 Max.
F	0.142 Dia.	3.6 Dia.
G	0.0787 Deep	2.0 Deep

14 TCS4

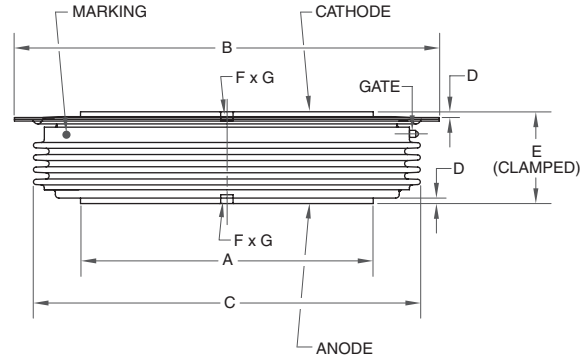

Dim.	Inches	Millimeters
A	3.311 Dia.	84.1 Dia.
B	4.889 Dia.	124.2 Dia.
C	4.370 Dia.	111.0 Dia.
D	0.028 Min.	0.7 Min.

Dim.	Inches	Millimeters
E	1.059 Max.	26.9 Max.
F	0.142 Dia.	3.6 Dia.
G	0.0787 Deep	2.0 Deep

15 TDS4

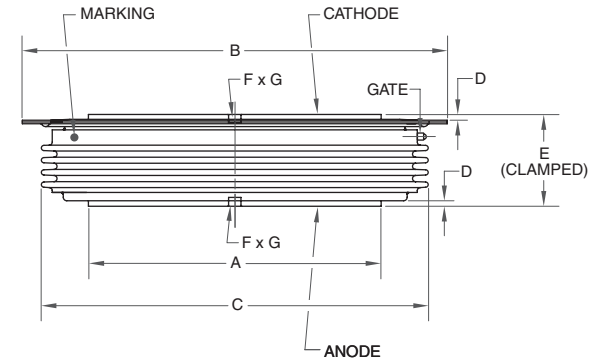

Dim.	Inches	Millimeters
A	3.913 Dia.	99.4 Dia.
B	5.661 Dia.	143.8 Dia.
C	5.181 Dia.	131.6 Dia.
D	0.028 Min.	0.7 Min.

Dim.	Inches	Millimeters
E	1.059 Max.	26.9 Max.
F	0.142 Dia.	3.6 Dia.
G	0.0787 Deep	2.0 Deep

16 TCU4

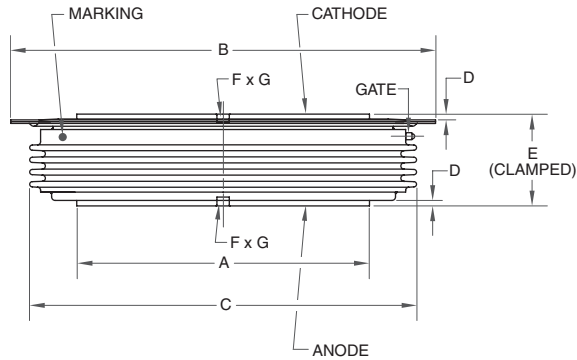

Dim.	Inches	Millimeters
A	3.311 Dia.	84.1 Dia.
B	4.72 Dia.	120.0 Dia.
C	4.370 Dia.	111.0 Dia.
D	0.028 Min.	0.7 Min.

Dim.	Inches	Millimeters
E	1.031 Max.	26.2 Max.
F	0.142 Dia.	3.6 Dia.
G	0.0787 Deep	2.0 Deep

17 T500, T507

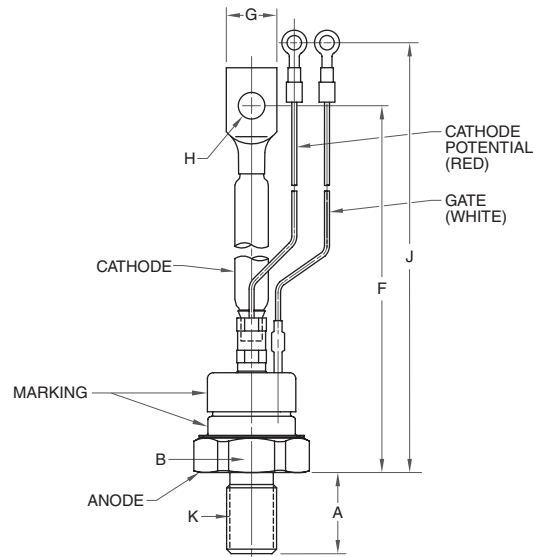

Dim.	Inches	Millimeters
A	0.815 Max.	20.7 Max.
B	1.059 Max.	26.9 Max.
F	6.240 Max.	158.5 Max.

Dim.	Inches	Millimeters
G	0.512 Max.	13.0 Max.
H	0.268 Dia.	6.8 Dia.
J	7.559 Max.	192.0 Max.
K	0.500-20 UNF-2A Thread	

18 T510

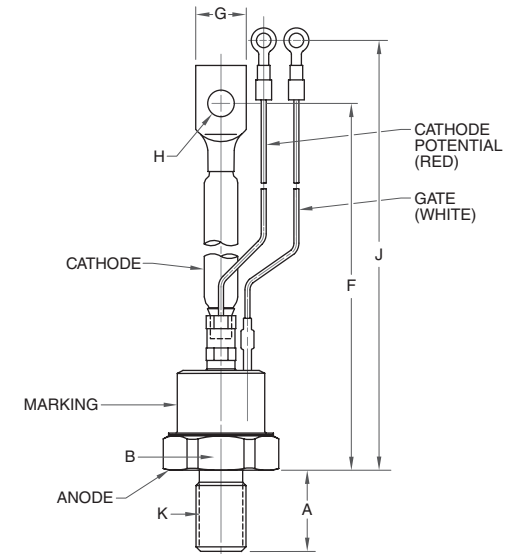

Dim.	Inches	Millimeters
A	0.815 Max.	20.7 Max.
B	1.059 Max.	26.9 Max.
F	6.240 Max.	158.5 Max.

Dim.	Inches	Millimeters
G	0.512 Max.	13.0 Max.
H	0.268 Dia.	6.8 Dia.
J	7.559 Max.	192.0 Max.
K	0.500-20 UNF-2A Thread	

19

T600, T607

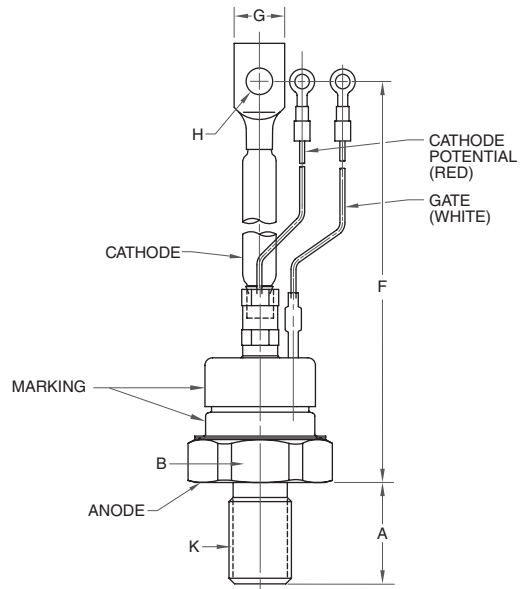

Dim.	Inches	Millimeters	Dim.	Inches	Millimeters
A	1.063 Max.	27.0 Max.	G	0.6299 Max.	16.0 Max.
B	1.252 Max.	31.8 Max.	H	0.2795 Dia.	7.1 Dia.
	(Across Flats)		K	0.75-16 UNF-2A Thread	
F	8.032 Max.	204.0 Max.			

20

T650

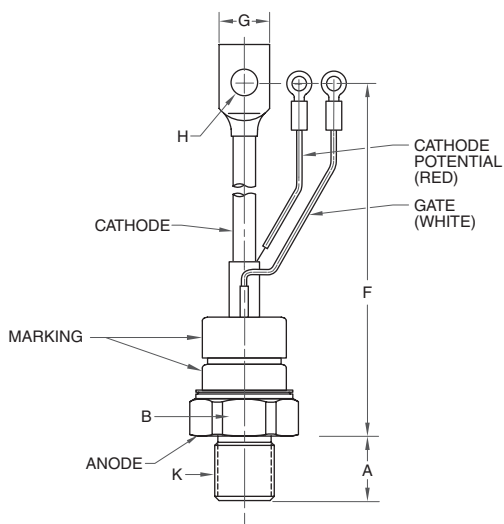

Dim.	Inches	Millimeters	Dim.	Inches	Millimeters
A	0.822 Max.	20.88 Max.	G	0.63 Max.	16.0 Max.
B	1.248 Max.	31.78 Max.	H	0.281 Dia.	7.14 Dia.
	(Across Flats)		K	0.750-16 UNF-2A Thread	
F	8.03 Max.	203.96 Max.			

21

T700, T707

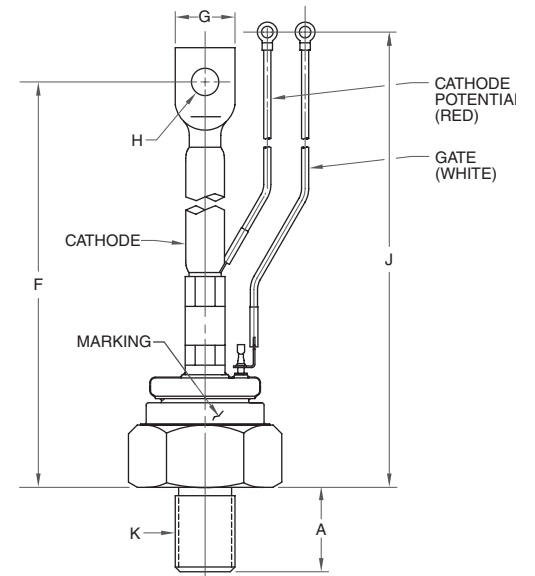

Dim.	Inches	Millimeters	Dim.	Inches	Millimeters
A	1.083 Max.	27.5 Max.	H	0.343 Dia.	8.7 Dia.
F	9.784 Max.	248.5 Max.	J	10.181 Max.	258.6 Max.
G	0.756 Max.	19.2 Max.	K	0.750-16 UNF-2A Thread	

22 T750

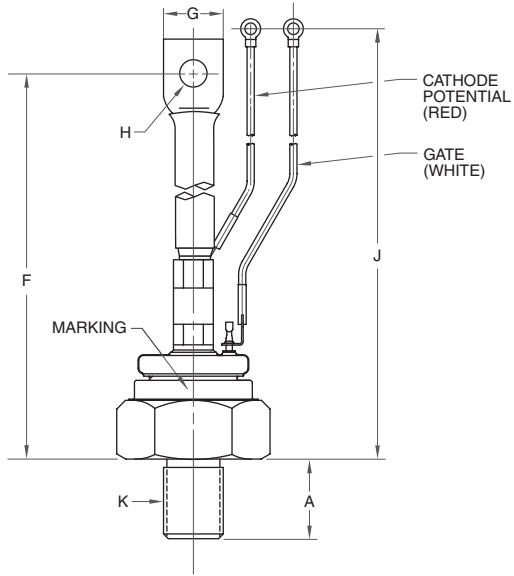

Dim.	Inches	Millimeters	Dim.	Inches	Millimeters
A	1.08 Max.	27.4 Max.	H	0.355 Dia.	9.0 Dia.
F	9.78 Max.	248.4 Max.	J	10.18 Max.	258.5 Max.
G	0.848 Max.	21.5 Max.	K	0.750-16 UNF-2A Thread	

