

OPA2604

www.burr-brown.com/databook/OPA2604.html

Dual FET-Input, Low Distortion OPERATIONAL AMPLIFIER

FEATURES

- **LOW DISTORTION:** 0.0003% at 1kHz
- **LOW NOISE:** $10\text{nV}/\sqrt{\text{Hz}}$
- **HIGH SLEW RATE:** $25\text{V}/\mu\text{s}$
- **WIDE GAIN-BANDWIDTH:** 20MHz
- **UNITY-GAIN STABLE**
- **WIDE SUPPLY RANGE:** $V_s = \pm 4.5$ to $\pm 24\text{V}$
- **DRIVES 600Ω LOADS**

APPLICATIONS

- PROFESSIONAL AUDIO EQUIPMENT
- PCM DAC I/V CONVERTER
- SPECTRAL ANALYSIS EQUIPMENT
- ACTIVE FILTERS
- TRANSDUCER AMPLIFIER
- DATA ACQUISITION

DESCRIPTION

The OPA2604 is a dual, FET-input operational amplifier designed for enhanced AC performance. Very low distortion, low noise and wide bandwidth provide superior performance in high quality audio and other applications requiring excellent dynamic performance.

New circuit techniques and special laser trimming of dynamic circuit performance yield very low harmonic distortion. The result is an op amp with exceptional sound quality. The low-noise FET input of the OPA2604 provides wide dynamic range, even with high source impedance. Offset voltage is laser-trimmed to minimize the need for interstage coupling capacitors.

The OPA2604 is available in 8-pin plastic mini-DIP and SO-8 surface-mount packages, specified for the -25°C to $+85^\circ\text{C}$ temperature range.

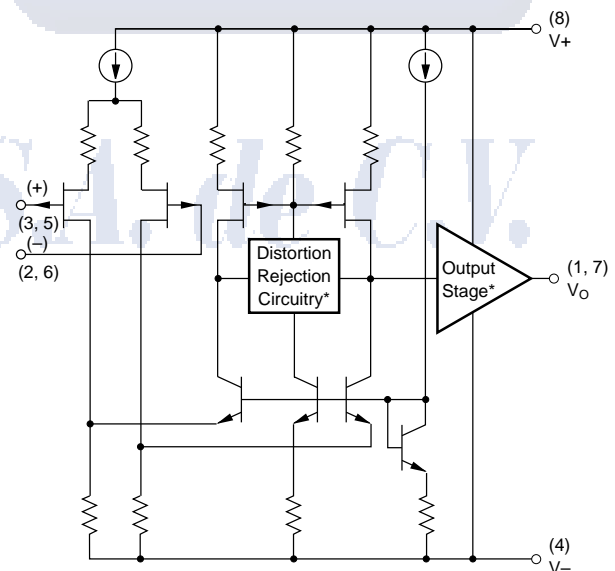

* Patents Granted:
#5053718, 5019789

International Airport Industrial Park • Mailing Address: PO Box 11400, Tucson, AZ 85734 • Street Address: 6730 S. Tucson Blvd., Tucson, AZ 85706 • Tel: (520) 746-1111 • Twx: 910-952-1111
Internet: <http://www.burr-brown.com/> • FAXLine: (800) 548-6133 (US/Canada Only) • Cable: BBRCORP • Telex: 066-6491 • FAX: (520) 889-1510 • Immediate Product Info: (800) 548-6132

SPECIFICATIONS

ELECTRICAL

At $T_A = +25^\circ\text{C}$, $V_S = \pm 15\text{V}$, unless otherwise noted.

PARAMETER	CONDITION	OPA2604AP, AU			UNITS
		MIN	TYP	MAX	
OFFSET VOLTAGE Input Offset Voltage Average Drift Power Supply Rejection	$V_S = \pm 5$ to $\pm 24\text{V}$	70	± 1 ± 8 80	± 5	mV $\mu\text{V}/^\circ\text{C}$ dB
INPUT BIAS CURRENT⁽¹⁾ Input Bias Current Input Offset Current	$V_{\text{CM}} = 0\text{V}$ $V_{\text{CM}} = 0\text{V}$		100 ± 4		pA pA
NOISE Input Voltage Noise Noise Density: $f = 10\text{Hz}$ $f = 100\text{Hz}$ $f = 1\text{kHz}$ $f = 10\text{kHz}$ Voltage Noise, BW = 20Hz to 20kHz Input Bias Current Noise Current Noise Density, $f = 0.1\text{Hz}$ to 20kHz			25 15 11 10 1.5 6		$\text{nV}/\sqrt{\text{Hz}}$ $\text{nV}/\sqrt{\text{Hz}}$ $\text{nV}/\sqrt{\text{Hz}}$ $\text{nV}/\sqrt{\text{Hz}}$ $\mu\text{Vp-p}$ $\text{fA}/\sqrt{\text{Hz}}$
INPUT VOLTAGE RANGE Common-Mode Input Range Common-Mode Rejection	$V_{\text{CM}} = \pm 12\text{V}$	± 12 80	± 13 100		V dB
INPUT IMPEDANCE Differential Common-Mode			$10^{12} \parallel 8$ $10^{12} \parallel 10$		$\Omega \parallel \text{pF}$ $\Omega \parallel \text{pF}$
OPEN-LOOP GAIN Open-Loop Voltage Gain	$V_O = \pm 10\text{V}$, $R_L = 1\text{k}\Omega$	80	100		dB
FREQUENCY RESPONSE Gain-Bandwidth Product Slew Rate Settling Time: 0.01% 0.1% Total Harmonic Distortion + Noise (THD+N) Channel Separation	$G = 100$ 20Vp-p , $R_L = 1\text{k}\Omega$ $G = -1$, 10V Step $G = 1$, $f = 1\text{kHz}$ $V_O = 3.5\text{Vrms}$, $R_L = 1\text{k}\Omega$ $f = 1\text{kHz}$, $R_L = 1\text{k}\Omega$	15	20 25 1.5 1 0.0003 142		MHz $\text{V}/\mu\text{s}$ μs μs % dB
OUTPUT Voltage Output Current Output Short Circuit Current Output Resistance, Open-Loop	$R_L = 600\Omega$ $V_O = \pm 12\text{V}$	± 11	± 12 ± 35 ± 40 25		V mA mA Ω
POWER SUPPLY Specified Operating Voltage Operating Voltage Range Current, Total Both Amplifiers	$I_O = 0$	± 4.5	± 15 ± 10.5	± 24 ± 12	V V mA
TEMPERATURE RANGE Specification Storage Thermal Resistance ⁽²⁾ , θ_{JA}		-25 -40		+85 +125 90	$^\circ\text{C}$ $^\circ\text{C}$ $^\circ\text{C}/\text{W}$

NOTES: (1) Typical performance, measured fully warmed-up. (2) Soldered to circuit board—see text.

The information provided herein is believed to be reliable; however, BURR-BROWN assumes no responsibility for inaccuracies or omissions. BURR-BROWN assumes no responsibility for the use of this information, and all use of such information shall be entirely at the user's own risk. Prices and specifications are subject to change without notice. No patent rights or licenses to any of the circuits described herein are implied or granted to any third party. BURR-BROWN does not authorize or warrant any BURR-BROWN product for use in life support devices and/or systems.



OPA2604

PIN CONFIGURATION

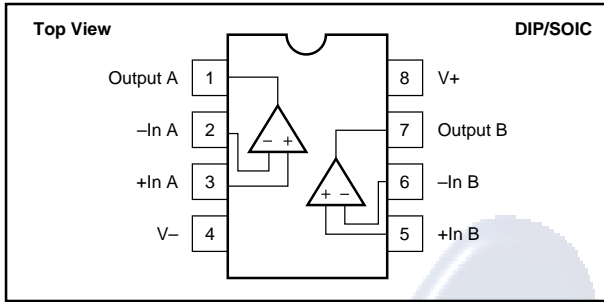

ELECTROSTATIC DISCHARGE SENSITIVITY

Any integrated circuit can be damaged by ESD. Burr-Brown recommends that all integrated circuits be handled with appropriate precautions. Failure to observe proper handling and installation procedures can cause damage.

ESD damage can range from subtle performance degradation to complete device failure. Precision integrated circuits may be more susceptible to damage because very small parametric changes could cause the device not to meet published specifications.

ABSOLUTE MAXIMUM RATINGS⁽¹⁾

Power Supply Voltage	±25V
Input Voltage	(V-) -1V to (V+) +1V
Output Short Circuit to Ground	Continuous
Operating Temperature	-40°C to +100°C
Storage Temperature	-40°C to +125°C
Junction Temperature	+150°C
Lead Temperature (soldering, 10s) AP	+300°C
Lead Temperature (soldering, 3s) AU	+260°C

NOTE: (1) Stresses above these ratings may cause permanent damage.

ORDERING INFORMATION

PRODUCT	PACKAGE	TEMP. RANGE
OPA2604AP	8-Pin Plastic DIP	-25°C to +85°C
OPA2604AU	SO-8 Surface-Mount	-25°C to +85°C

PACKAGING INFORMATION

PRODUCT	PACKAGE	PACKAGE DRAWING NUMBER ⁽¹⁾
OPA2604AP	8-Pin Plastic DIP	006
OPA2604AU	SO-8 Surface-Mount	182

NOTE: (1) For detailed drawing and dimension table, please see end of data sheet, or Appendix C of Burr-Brown IC Data Book.

Electrónica S.A. de C.V.

TYPICAL PERFORMANCE CURVES

At $T_A = +25^\circ\text{C}$, $V_S = \pm 15\text{V}$, unless otherwise noted.

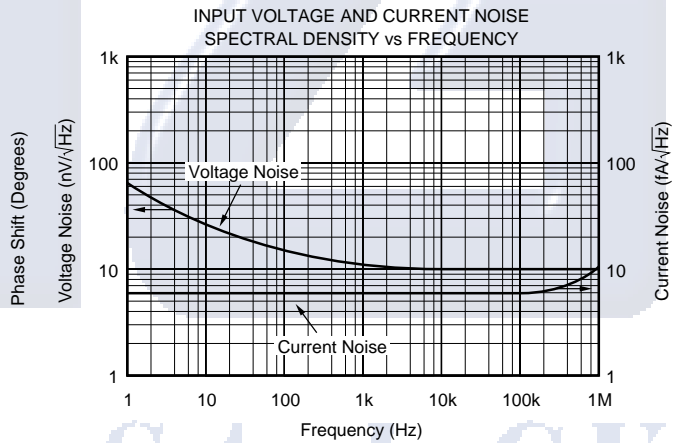
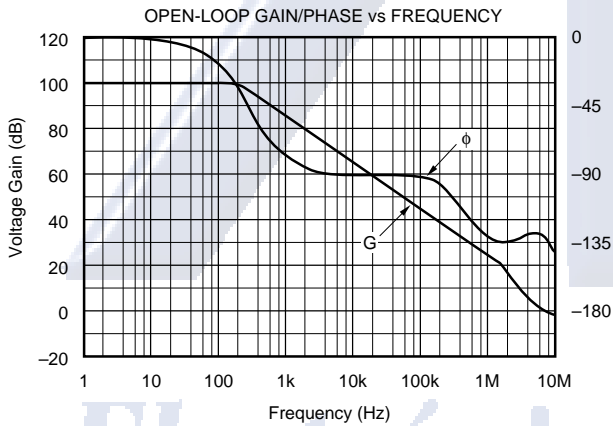
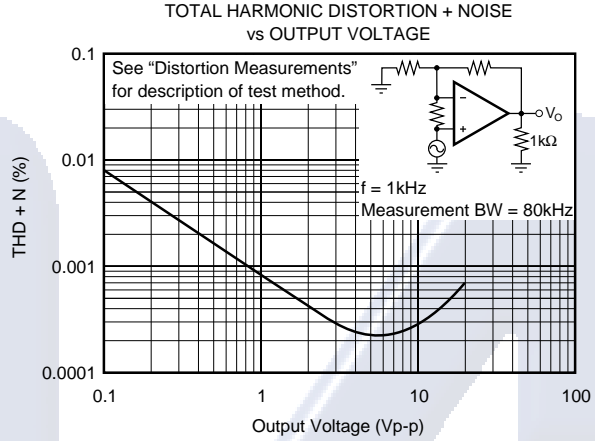
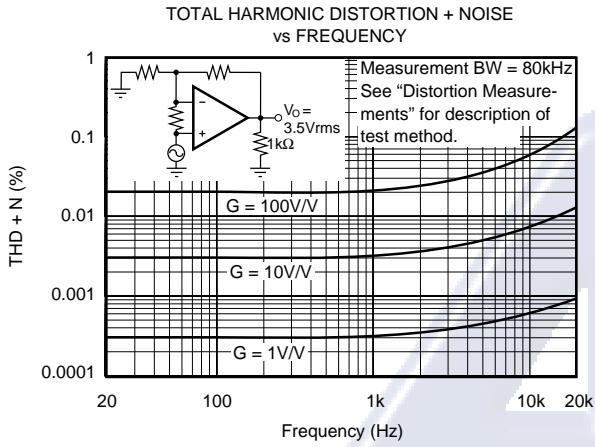

Electrónica S.A. de C.V.

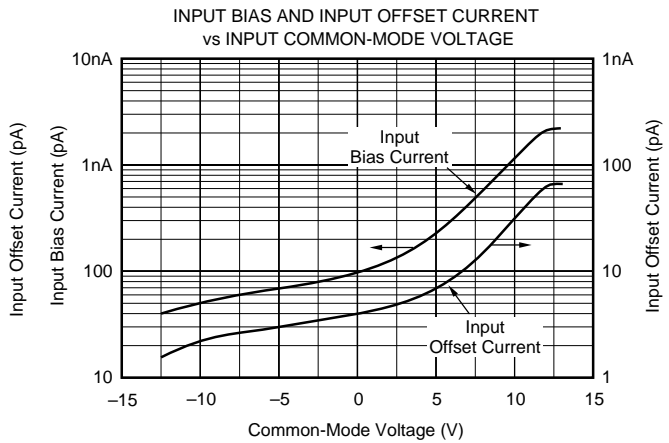
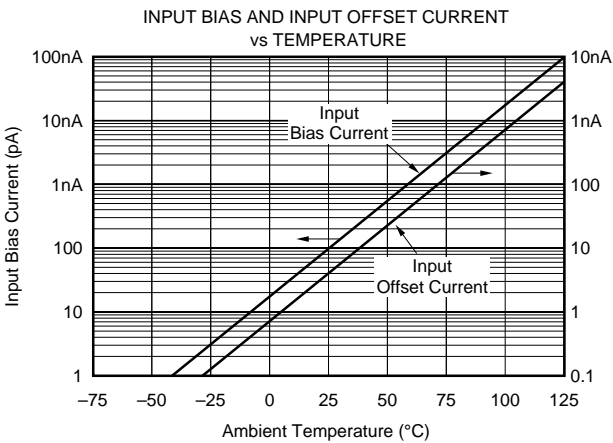

TYPICAL PERFORMANCE CURVES (CONT)

At $T_A = +25^\circ\text{C}$, $V_S = \pm 15\text{VDC}$, unless otherwise noted.

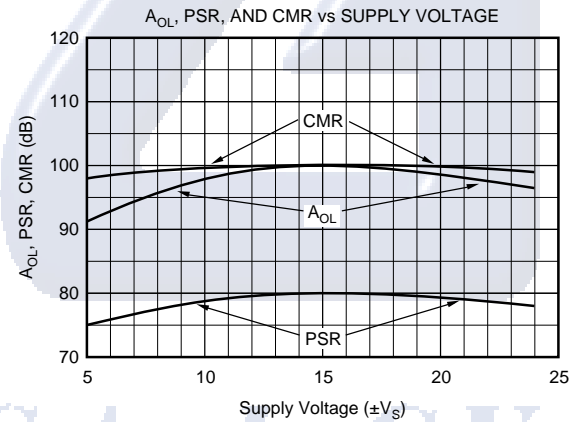
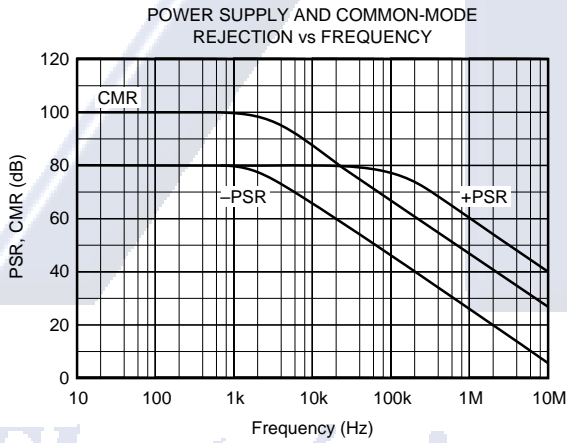
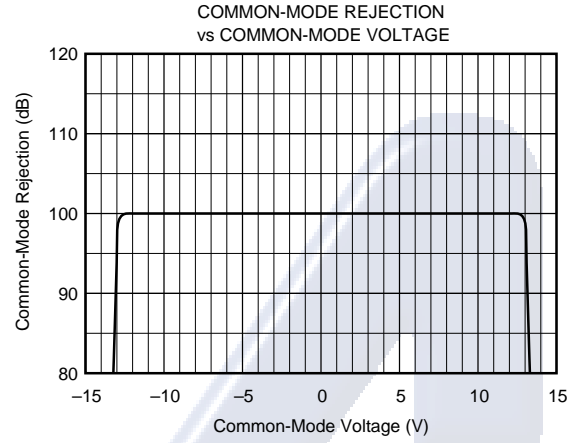
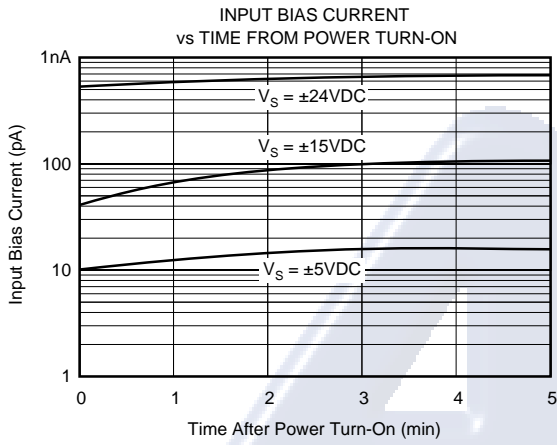

Electrónica S.A. de C.V.

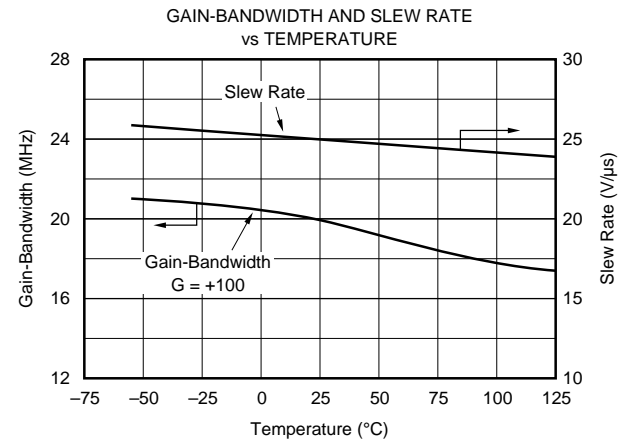
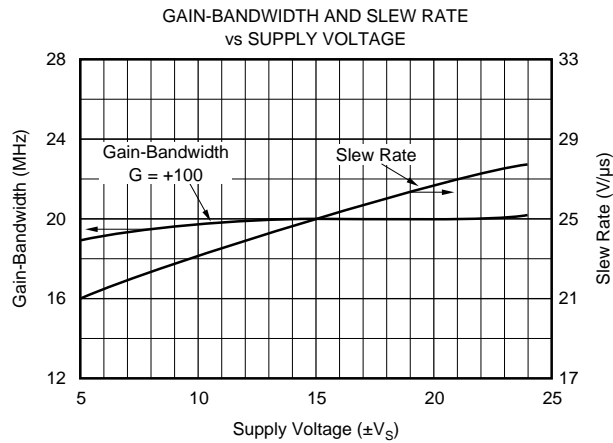

TYPICAL PERFORMANCE CURVES (CONT)

At $T_A = +25^\circ\text{C}$, $V_S = \pm 15\text{V}$, unless otherwise noted.

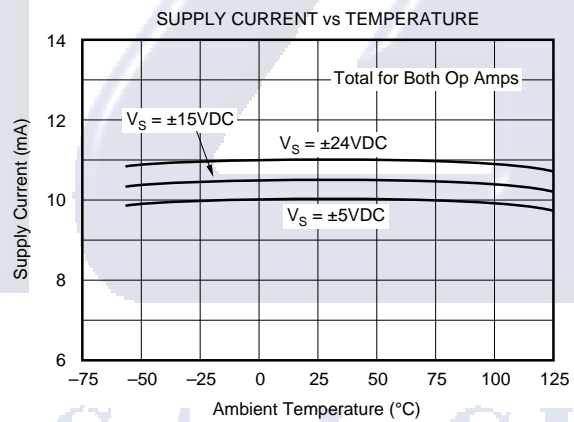
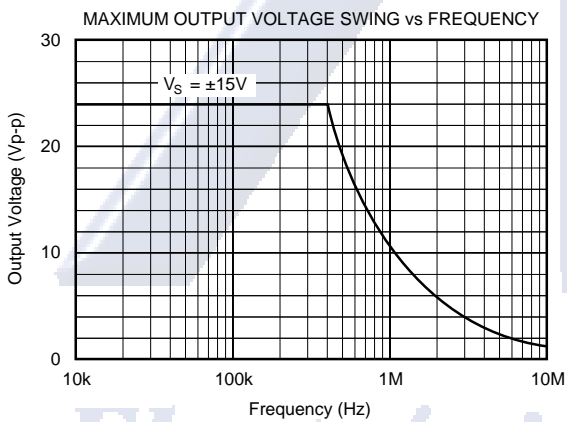
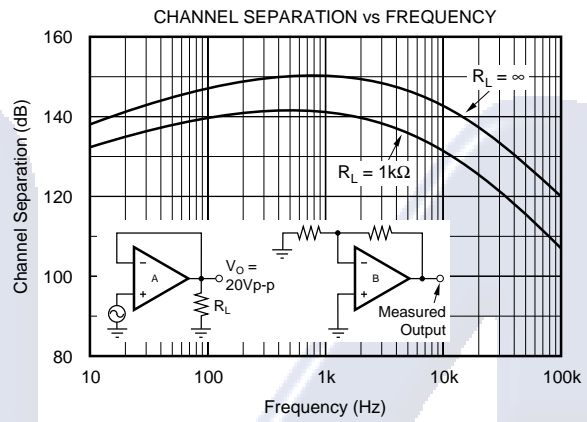
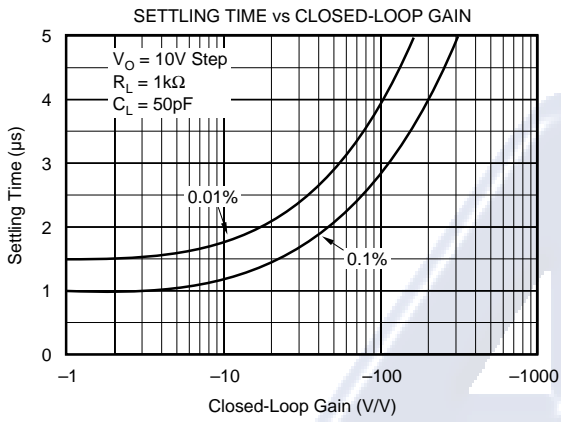

Electrónica S.A. de C.V.

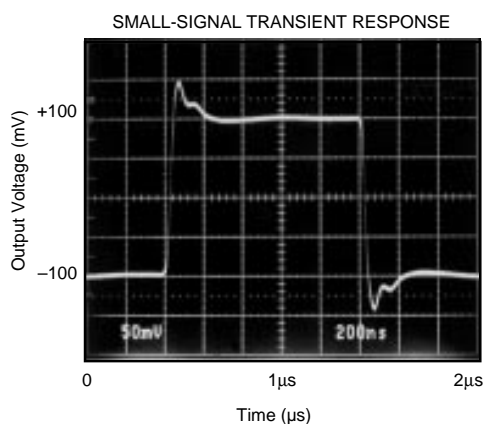
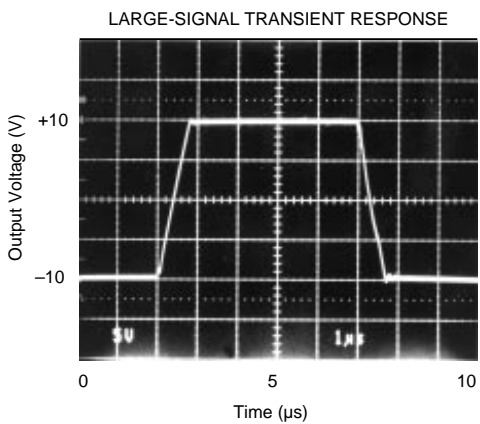

TYPICAL PERFORMANCE CURVES (CONT)

At $T_A = +25^\circ\text{C}$, $V_S = \pm 15\text{V}$, unless otherwise noted.

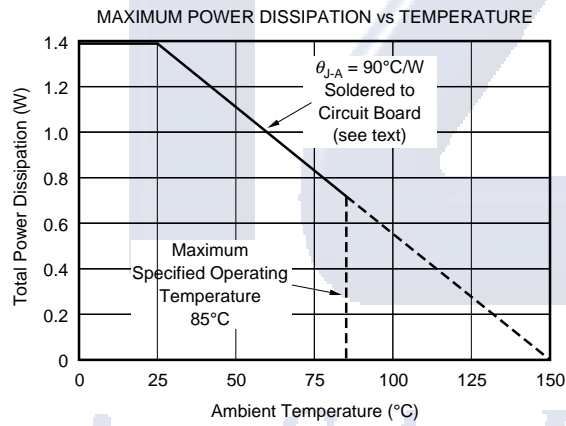
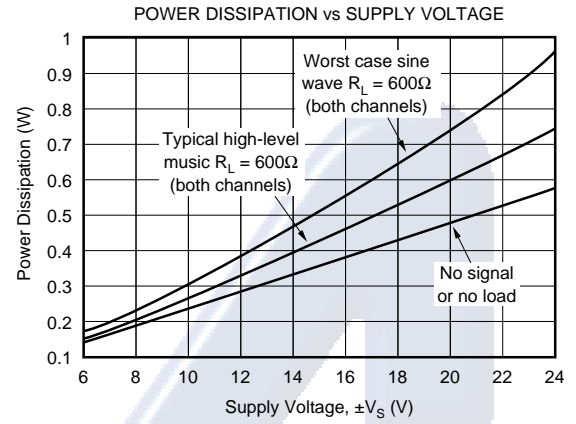
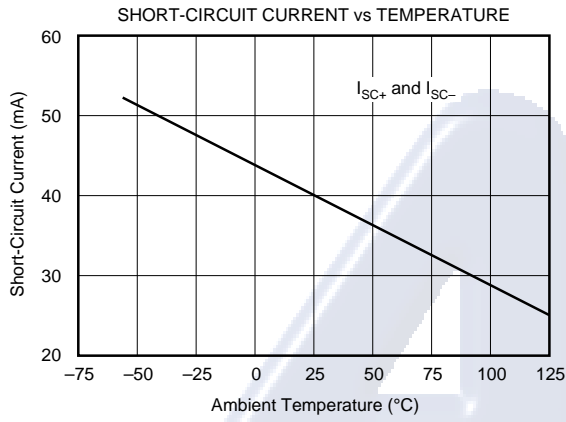

Electrónica S.A. de C.V.

APPLICATIONS INFORMATION

The OPA2604 is unity-gain stable, making it easy to use in a wide range of circuitry. Applications with noisy or high impedance power supply lines may require decoupling capacitors close to the device pins. In most cases 1μF tantalum capacitors are adequate.

DISTORTION MEASUREMENTS

The distortion produced by the OPA2604 is below the measurement limit of virtually all commercially available equipment. A special test circuit, however, can be used to extend the measurement capabilities.

Op amp distortion can be considered an internal error source which can be referred to the input. Figure 1 shows a circuit which causes the op amp distortion to be 101 times greater than normally produced by the op amp. The addition of R_3 to the otherwise standard non-inverting amplifier configuration alters the feedback factor or noise gain of the circuit. The closed-loop gain is unchanged, but the feedback available for error correction is reduced by a factor of 101. This extends the measurement limit, including the effects of the signal-source purity, by a factor of 101. Note that the input signal and load applied to the op amp are the same as with conventional feedback without R_3 .

Validity of this technique can be verified by duplicating measurements at high gain and/or high frequency where the distortion is within the measurement capability of the test equipment. Measurements for this data sheet were made with the Audio Precision System One which greatly simplifies such repetitive measurements. The measurement technique can, however, be performed with manual distortion measurement instruments.

CAPACITIVE LOADS

The dynamic characteristics of the OPA2604 have been optimized for commonly encountered gains, loads and operating conditions. The combination of low closed-loop gain

and capacitive load will decrease the phase margin and may lead to gain peaking or oscillations. Load capacitance reacts with the op amp's open-loop output resistance to form an additional pole in the feedback loop. Figure 2 shows various circuits which preserve phase margin with capacitive load. Request Application Bulletin AB-028 for details of analysis techniques and applications circuits.

For the unity-gain buffer, Figure 2a, stability is preserved by adding a phase-lead network, R_C and C_C . Voltage drop across R_C will reduce output voltage swing with heavy loads. An alternate circuit, Figure 2b, does not limit the output with low load impedance. It provides a small amount of positive feedback to reduce the net feedback factor. Input impedance of this circuit falls at high frequency as op amp gain rolloff reduces the bootstrap action on the compensation network.

Figures 2c and 2d show compensation techniques for noninverting amplifiers. Like the follower circuits, the circuit in Figure 2d eliminates voltage drop due to load current, but at the penalty of somewhat reduced input impedance at high frequency.

Figures 2e and 2f show input lead compensation networks for inverting and difference amplifier configurations.

NOISE PERFORMANCE

Op amp noise is described by two parameters—noise voltage and noise current. The voltage noise determines the noise performance with low source impedance. Low noise bipolar-input op amps such as the OPA27 and OPA37 provide very low voltage noise. But if source impedance is greater than a few thousand ohms, the current noise of bipolar-input op amps react with the source impedance and will dominate. At a few thousand ohms source impedance and above, the OPA2604 will generally provide lower noise.

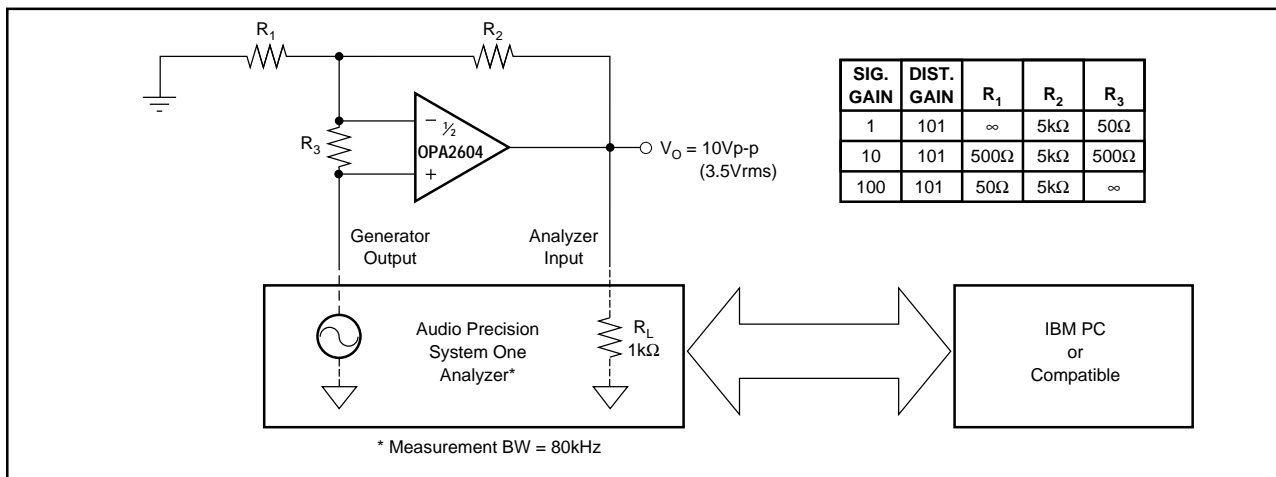

FIGURE 1. Distortion Test Circuit.

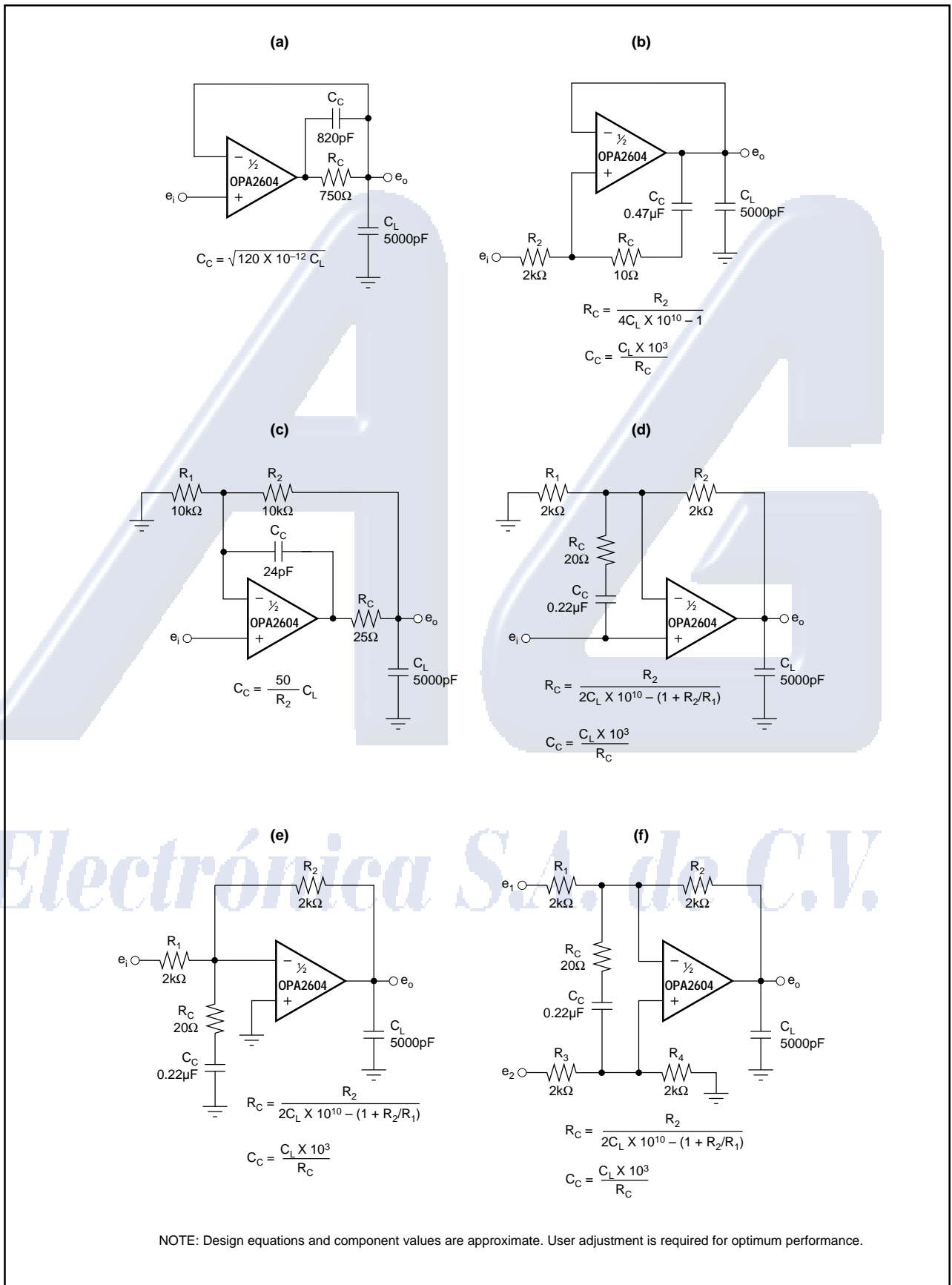

FIGURE 2. Driving Large Capacitive Loads.

POWER DISSIPATION

The OPA2604 is capable of driving 600Ω loads with power supply voltages up to ±24V. Internal power dissipation is increased when operating at high power supply voltage. The typical performance curve, Power Dissipation vs Power Supply Voltage, shows quiescent dissipation (no signal or no load) as well as dissipation with a worst case continuous sine wave. Continuous high-level music signals typically produce dissipation significantly less than worst case sine waves.

Copper leadframe construction used in the OPA2604 improves heat dissipation compared to conventional plastic packages. To achieve best heat dissipation, solder the device directly to the circuit board and use wide circuit board traces.

OUTPUT CURRENT LIMIT

Output current is limited by internal circuitry to approximately ±40mA at 25°C. The limit current decreases with increasing temperature as shown in the typical curves.

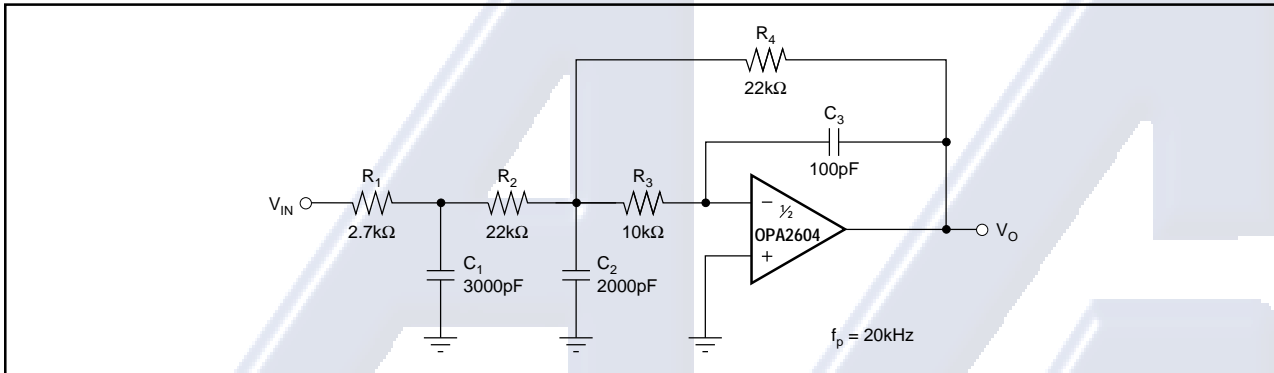

FIGURE 3. Three-Pole Low-Pass Filter.

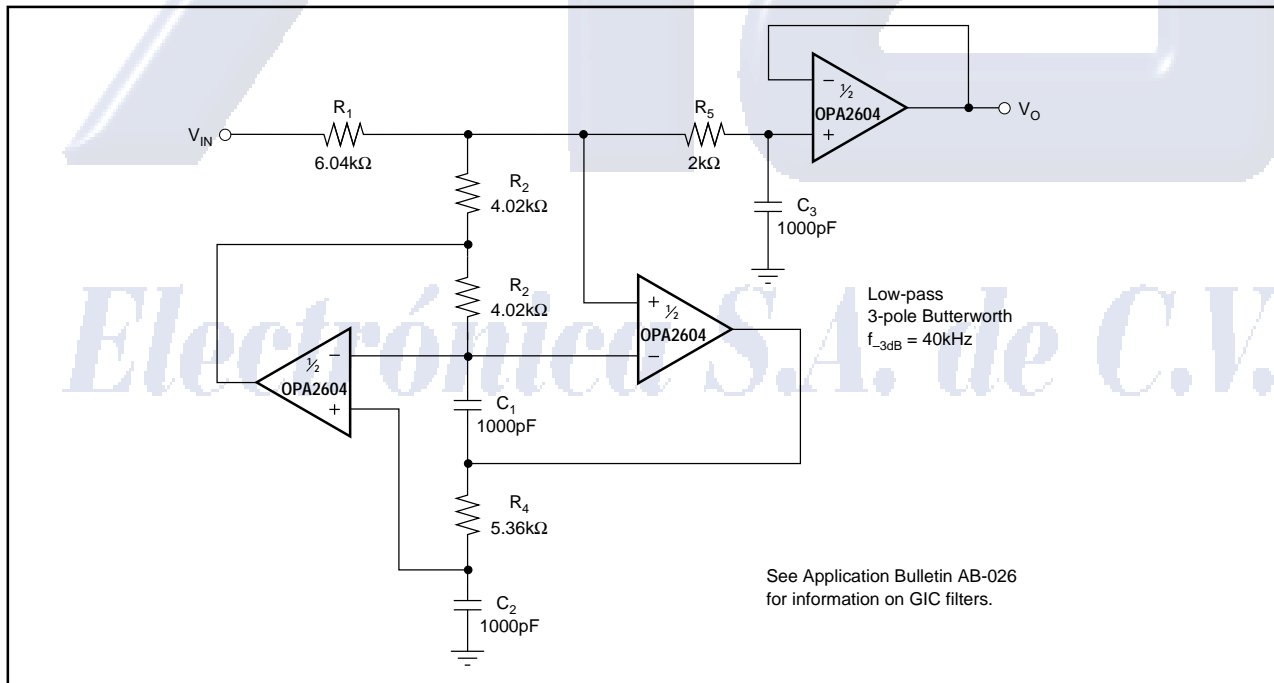

FIGURE 4. Three-Pole Generalized Immittance Converter (GIC) Low-Pass Filter.

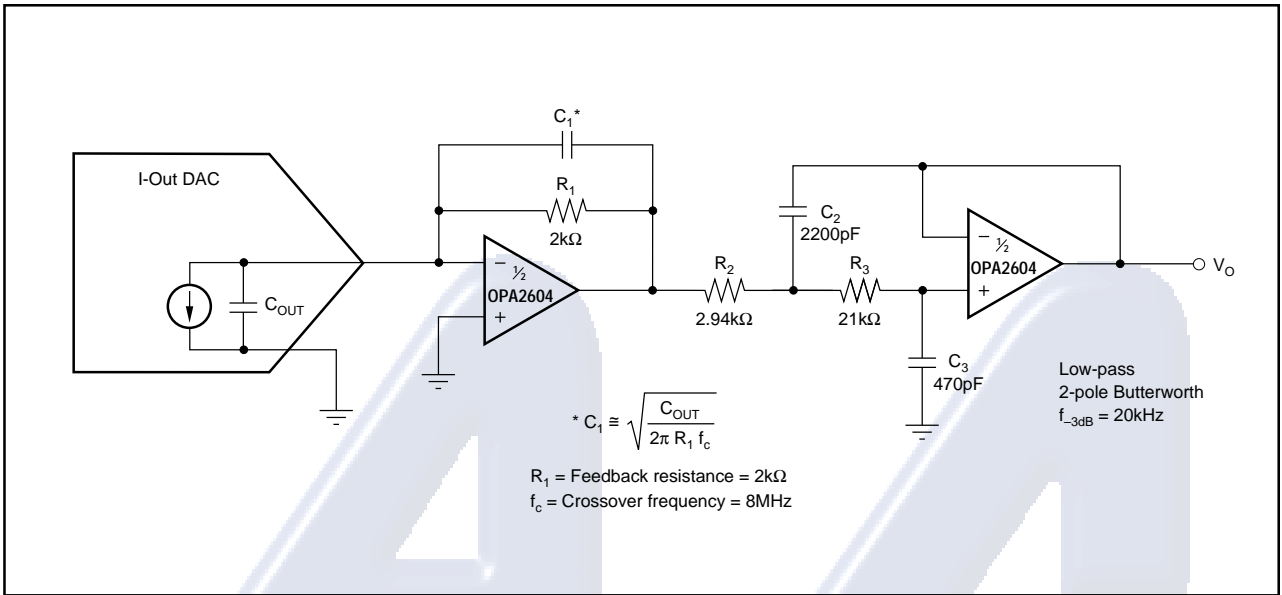

FIGURE 5. DAC I/V Amplifier and Low-Pass Filter.

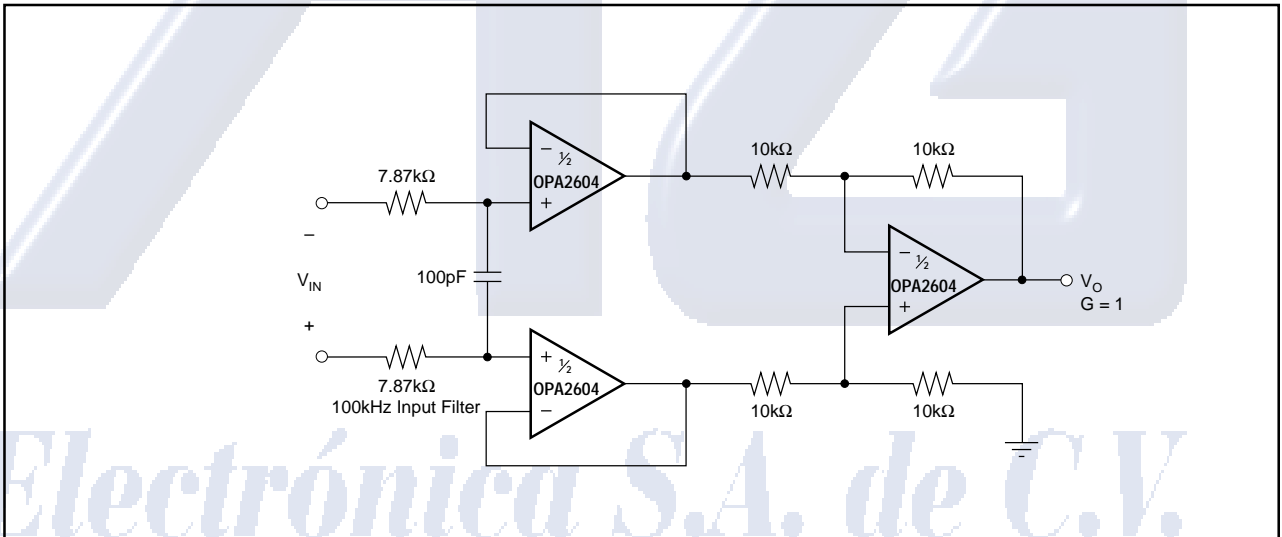

FIGURE 6. Differential Amplifier with Low-Pass Filter.

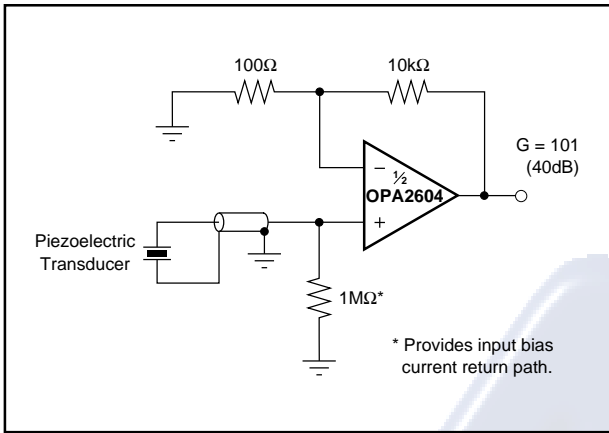

FIGURE 7. High Impedance Amplifier.

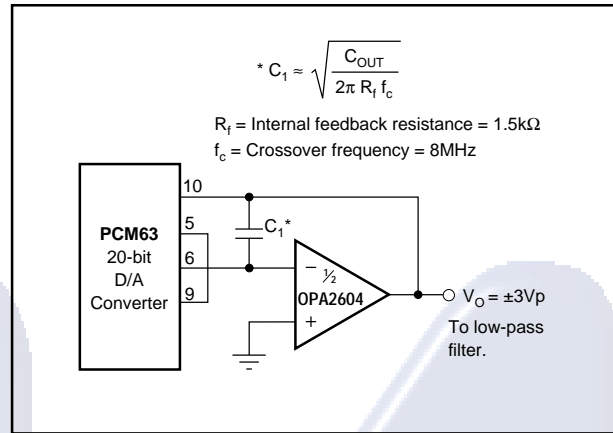

FIGURE 8. Digital Audio DAC I-V Amplifier.

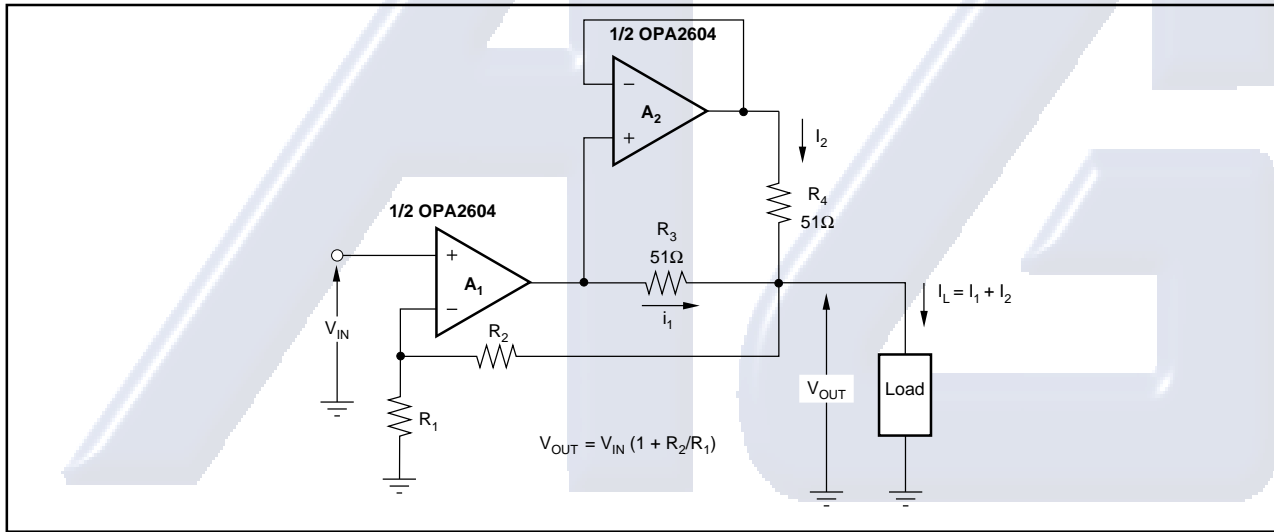

FIGURE 9. Using the Dual OPA2604 Op Amp to Double the Output Current to a Load.

Electrónica S.A. de C.V.