

# RF-300EA



Precious metal-brush motors

**OUTPUT : 0.02W~1.8W (APPROX)**

**WEIGHT : 22g (APPROX)**

**Typical Applications** Office Automation Equipment : CD/DVD-ROM Drive  
 Audio and Visual Equipment : Car CD Player / DVD Player

MODEL	VOLTAGE		NO LOAD		AT MAXIMUM EFFICIENCY				STALL			
	OPERATING RANGE	NOMINAL	SPEED r/min	CURRENT A	SPEED r/min	CURRENT A	TORQUE mN-m	TORQUE g-cm	OUTPUT W	TORQUE mN-m	TORQUE g-cm	CURRENT A
RF-300EA-1D390	2.8~7.0	3.9V CONSTANT	4400	0.021	3520	0.084	0.47	4.8	0.17	2.35	24	0.34
RF-300EA-8Z485	1.6~11.0	8V CONSTANT	7100	0.021	5760	0.090	0.62	6.3	0.37	3.28	33	0.39

Also available with terminals (without leadwires).

## DIRECTION OF ROTATION

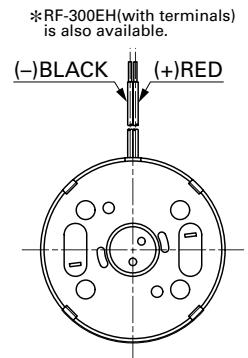
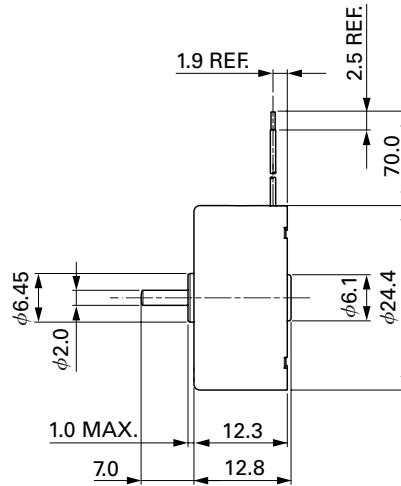
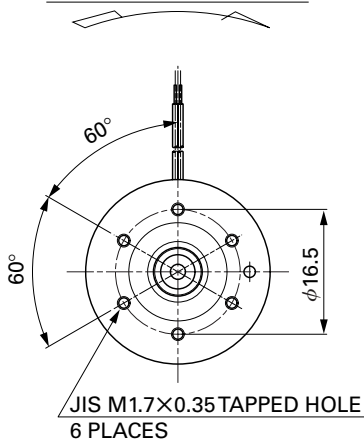

Usable machine screw length 1.1 max. from motor mounting surface.

UNIT: MILLIMETERS

### RF-300EA-1D390

3.9V

### RF-300EA-8Z485

8.0V

