

isc Silicon PNP Power Transistor

2SB1038

DESCRIPTION

- Collector-Emitter Breakdown Voltage-
: $V_{(BR)CEO} = -60V(\text{Min.})$
- Low Collector Saturation Voltage
: $V_{CE(sat)} = -1.5V(\text{Max})@I_C = -2A$
- Complement to Type 2SD1310

APPLICATIONS

- Designed for low frequency power amplifier applications.

ABSOLUTE MAXIMUM RATINGS($T_a=25^\circ\text{C}$)

SYMBOL	PARAMETER	VALUE	UNIT
V_{CBO}	Collector-Base Voltage	-60	V
V_{CEO}	Collector-Emitter Voltage	-60	V
V_{EBO}	Emitter-Base Voltage	-7	V
I_C	Collector Current-Continuous	-3	A
I_{CM}	Collector Current-Peak	-5	A
I_B	Base Current-Continuous	-0.6	A
P_C	Total Power Dissipation @ $T_C=25^\circ\text{C}$	30	W
T_J	Junction Temperature	150	$^\circ\text{C}$
T_{stg}	Storage Temperature Range	-55~150	$^\circ\text{C}$

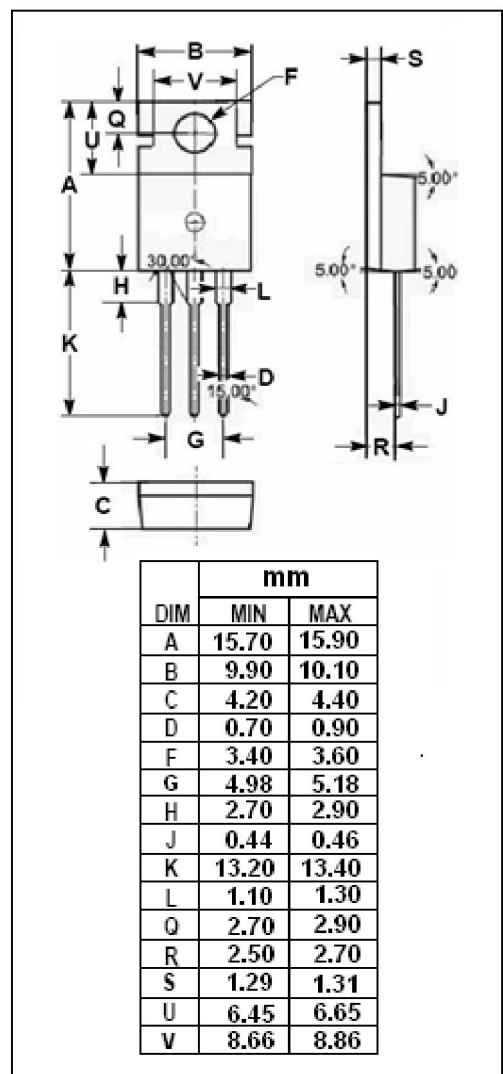
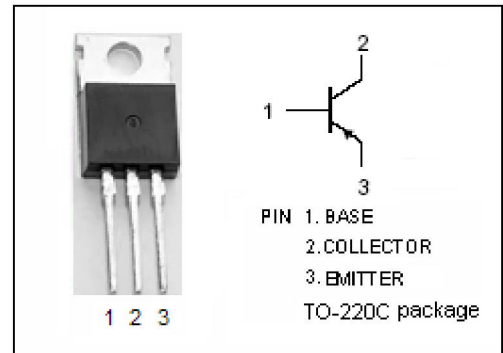

isc Silicon PNP Power Transistor**2SB1038****ELECTRICAL CHARACTERISTICS** $T_C=25^{\circ}\text{C}$ unless otherwise specified

SYMBOL	PARAMETER	CONDITIONS	MIN	TYP.	MAX	UNIT
$V_{(BR)CEO}$	Collector-Emitter Breakdown Voltage	$I_C = -10\text{mA}; I_B = 0$	-60			V
$V_{CE(sat)}$	Collector-Emitter Saturation Voltage	$I_C = -2\text{A}; I_B = -0.2\text{A}$			-1.5	V
$V_{BE(sat)}$	Base-Emitter Saturation Voltage	$I_C = -2\text{A}; I_B = -0.2\text{A}$			-2.0	V
I_{CBO}	Collector Cutoff Current	$V_{CB} = -60\text{V}; I_E = 0$			-10	μA
I_{EBO}	Emitter Cutoff Current	$V_{EB} = -7\text{V}; I_C = 0$			-10	μA
h_{FE-1}	DC Current Gain	$I_C = -50\text{mA}; V_{CE} = -5\text{V}$	20			
h_{FE-2}	DC Current Gain	$I_C = -0.5\text{A}; V_{CE} = -5\text{V}$	40		200	
f_T	Current-Gain—Bandwidth Product	$I_C = -0.1\text{A}; V_{CE} = -5\text{V}$		20		MHz
C_{OB}	Output Capacitance	$I_E = 0; V_{CB} = -10\text{V}; f = 1\text{MHz}$		70		pF

◆ h_{FE-2} Classifications

M	L	K
40-80	60-120	100-200