



General Description

The EC48324 consists of four independent, high gain and internally frequency compensated operational amplifiers. It is specifically designed to operate from a single power supply. Operation from split power supply is also possible and the low power supply current drain is independent of the magnitude of the power supply voltages.

The EC48324 series are Compatible with Industry standard 324.

The EC48324 series are available in 3 Packages: DIP-14' SOIC-14' TSSOP-14

Features

- Internally Frequency Compensated
- Large Voltage Gain
- Low Input Bias Current
- Low Input Offset Voltage
- Large Output Voltage Swing
- Wide Power Supply Voltage Range: Single Supply 3V to 18V or Dual Supplies $\pm 1.5V$ to $\pm 9V$
- Low Supply Current Drain: 500 μ A

Applications

- Battery Charger
- Cordless Telephone
- Switching Power Supply

Pin Configuration

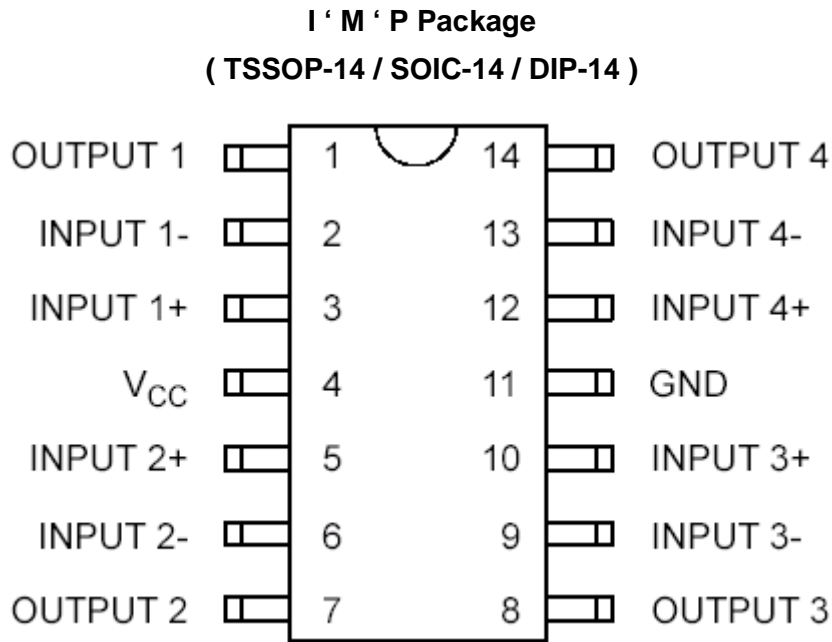

Figure 2. Pin Configuration of EC48324 (Top View)

Functional Block Diagram

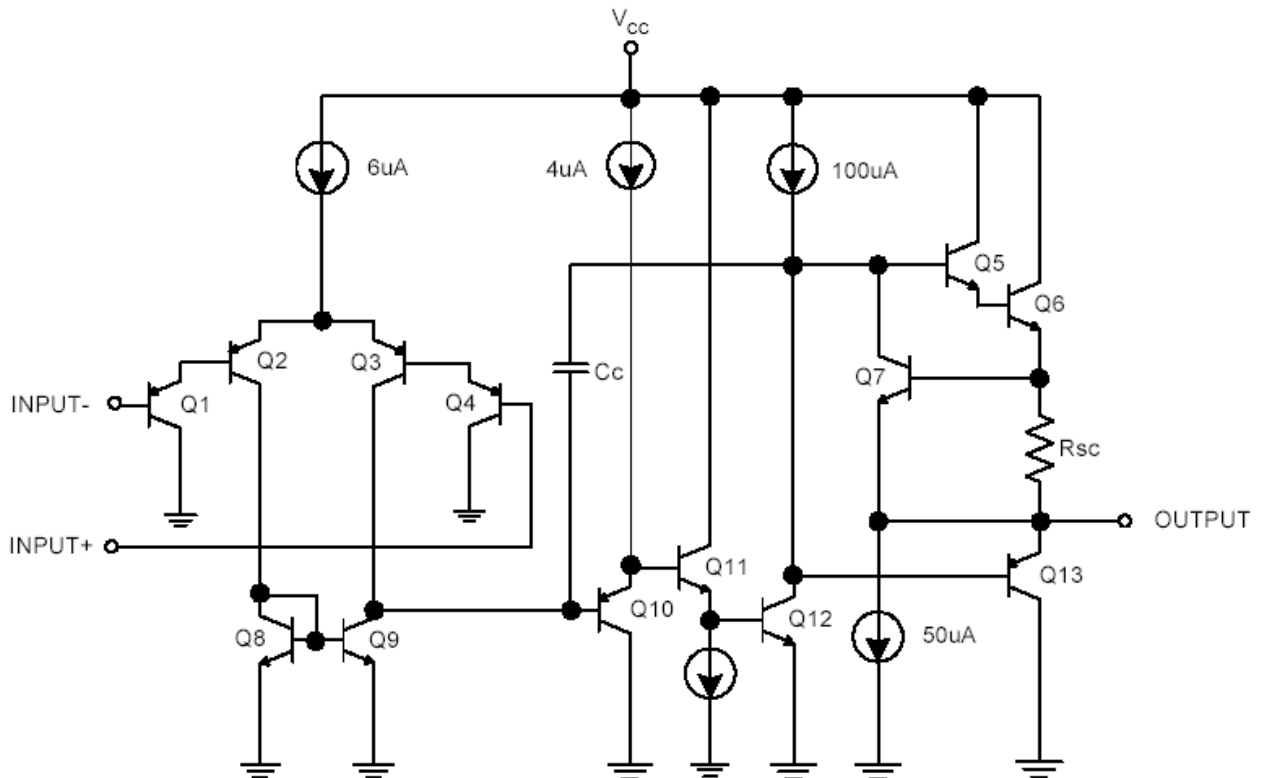

Figure 3. Functional Block Diagram of EC48324 (Each Amplifier)



Ordering Information

Package	Temperature Range	Part Number	Marking ID	Packing Type
TSSOP-14	-40 to 85°C	EC48324I-F	EC48324-F	Lead Free Tube/ Reel
SOIC-14		EC48324N-F	EC48324N-F	
DIP-14		EC48324P	EC48324P	Reel

Some of our products are available in Lead Free packages; If buyers need Lead Free or Green mode product, please add -F or -G after the part number in your order. For example, EC48324I is a standard tin-lead product, EC48324I-F means a Lead Free product.

Absolute Maximum Ratings (Note 1)

Parameter	Symbol	Value	Unit
Power Supply Voltage	V_{CC}	20	V
Differential Input Voltage	V_{ID}	20	V
Input Voltage	V_{IC}	-0.3 to 20	V
Input Current ($V_{IN} < -0.3V$) (Note 2)	I_{IN}	50	mA
Output Short Circuit to Ground (One Amplifier) $V_{CC} \leq 12V$ and $T_A = 25^\circ C$ (Note 3)		Continuous	
Power Dissipation	P_D	DIP : 1130	mW
		SOIC : 800	
Operating Temperature Range	T_{OP}	-40 to 85	°C
Storage Temperature Range	T_{STG}	-65 to 150	°C
Lead Temperature (Soldering, 10 Seconds)		260	°C
ESD (Machine Model)		200	V

Note 1: Stresses greater than those listed under "Absolute Maximum Ratings" may cause permanent damage to the device. These are stress ratings only, and functional operation of the device under these conditions is not implied. Exposure to "Absolute Maximum Ratings" for extended periods may affect device reliability.

Note 2: This input current will only exist when the voltage at any of the input leads is driven negative. It is due to the collector-base junction of the input PNP transistors becoming forward biased and thereby acting as input diode clamps. In addition to this diode action, there is also lateral NPN parasitic transistor action on the IC chip. This transistor action can cause the output voltages of the op amps to go to the V_{CC} voltage level (or to ground for a large overdrive) for the time duration that an input is driven negative. This is not destructive and normal output states will re-establish when the input voltage, which was negative, again returns to a value greater than -0.3V (at 25°C)

Note 3: Short circuits from the output to V_{CC} can cause excessive heating and eventual destruction. When considering short circuits to ground, the maximum output current is approximately 40mA independent of the magnitude of V_{CC} . At values of supply voltage in excess of +12V, continuous short-circuits can exceed the power dissipation ratings and cause eventual destruction. Destructive dissipation can result from simultaneous shorts on all amplifiers.

Electrical Characteristics

Operating Conditions : $V_{CC} = +5V$, $GND = 0V$, $T_A = 25^\circ C$ unless otherwise specified.

Parameter	Symbol	Test Conditions	Min	Typ	Max	Unit
Input Offset Voltage	V_{IO}	$V_O = 1.4V$, $R_S = 0\Omega$, $V_{CC} : \text{from } 5V \text{ to } 15V$		2	5	mV
Input Bias Current (Note 4)	I_{BIAS}	I_{IN+} or I_{IN-} , $V_{CM} = 0V$		20	200	nA
Input Offset Current	I_{IO}	I_{IN+} or I_{IN-} , $V_{CM} = 0V$		5	20	nA
Input Common Mode Voltage Range (Note 5)	V_{IR}	$V_{CC} = 15V$	0		$V_{CC} - 1.5$	V
Supply Current	I_{CC}	$R_L = \infty$, Over full temperature range on all OP Amps				mA
		$V_{CC} = 15V$		1	2	
		$V_{CC} = 5V$		0.5	1.2	
Large Signal Voltage Gain	G_V	$V_{CC} = 15V$, $R_L \geq 2K\Omega$, $V_O = 1V$ to $11V$	85	100		dB
Common Mode Rejection Ratio	CMRR	DC , $V_{CC} = 15V$, $V_{CM} = 0V$ to $(V_{CC} - 1.5)V$	65	85		dB
Power Supply Rejection Ratio	PSRR	$V_{CC} = 5V$ to $15V$	70	90		dB
Channel Separation (Note 6)	CS	$f = 1KHz$ to $20KHz$ (Input Referred)		-120		dB
Output Current	Source	I_{SOURCE} , $V_+ = 1V$, $V_- = 0V$, $V_{CC} = 15V$, $V_O = 2V$	20	45		mA
	Sink	I_{SINK} , $V_- = 1V$, $V_+ = 0V$, $V_{CC} = 15V$, $V_O = 2V$	10	20		mA
		I_{SINK} , $V_- = 1V$, $V_+ = 0V$, $V_{CC} = 15V$, $V_O = 200mV$	12	50		μA
Short Circuit to Ground	I_{SC}	$V_{CC} = 15V$		45	60	mA
Output Voltage Swing	V_{OH}	$R_L = 2K\Omega$, $V_{CC} = 15V$	12			V
		$R_L = 10K\Omega$, $V_{CC} = 15V$	12.5	13.5		
	V_{OL}	$R_L = 10K\Omega$, $V_{CC} = 5V$		5	20	mV

Note 4: The direction of the input current is out of the IC due to the PNP input stage. This current is essentially constant, independent of the state of the output so no loading change exists on the input lines.

Note 5: The input common-mode voltage of either input signal voltage should not be allowed to go negatively by more than 0.3V (at $25^\circ C$). The upper end of the common-mode voltage range is $V_{CC} - 1.5V$ (at $25^\circ C$), but either or both inputs can go to +18V without damages, independent of the magnitude of the V_{CC} .

Note 6: Due to proximity of external components, insure that coupling is not originating via stray capacitors between these external parts. This typically can be detected as this type of capacitance increases at higher frequencies.

Typical Performance Characteristics

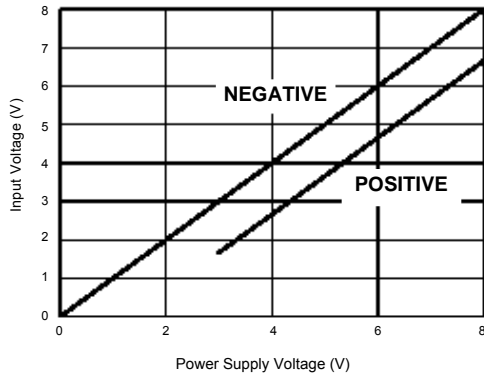

Figure 4. Input Voltage Range

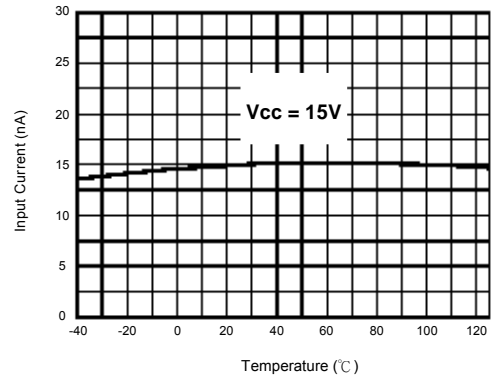

Figure 5. Input Current

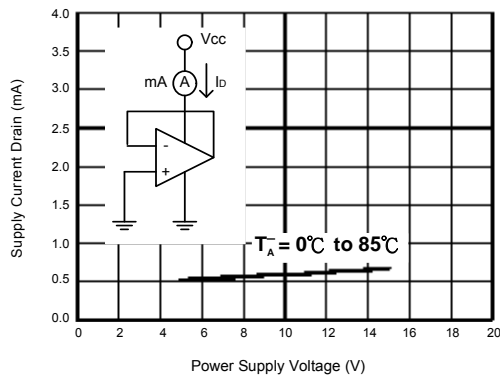

Figure 6. Supply Current

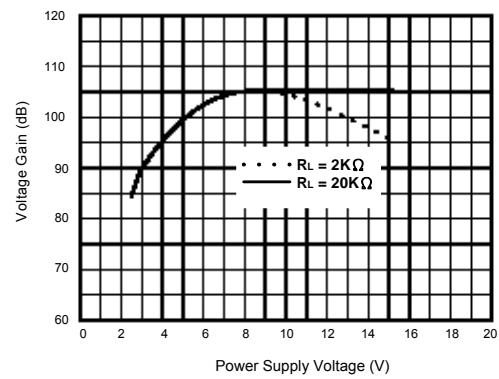

Figure 7. Voltage Gain

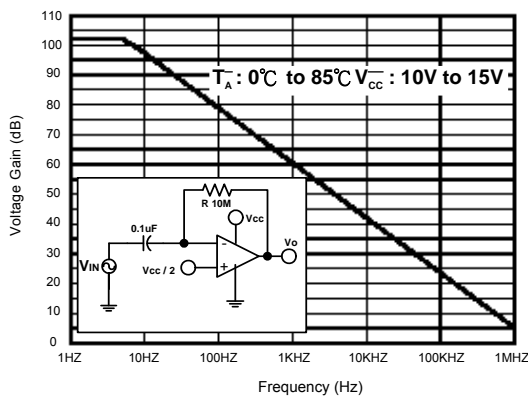

Figure 8. Open Loop Frequency Response

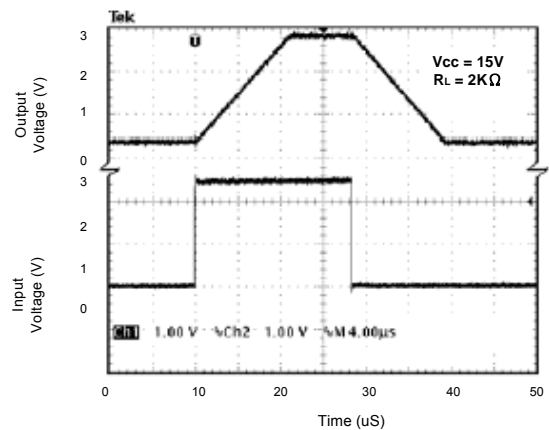

Figure 9. Voltage Follower Pulse Response

Typical Performance Characteristics (Continued)

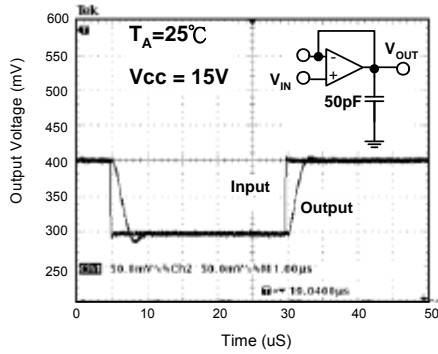

Figure 10. Voltage Follower Pulse Response (Small Signal)

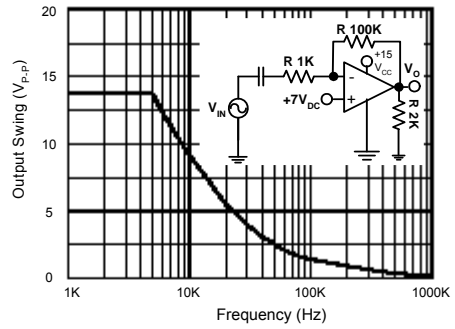

Figure 11. Large Signal Frequency Response

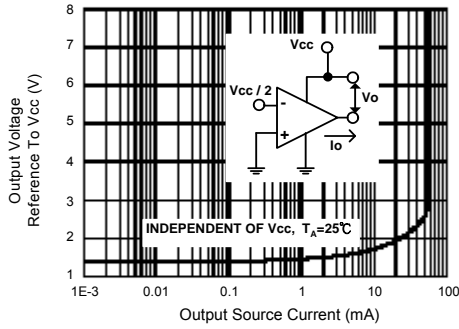

Figure 12. Output Characteristics Current Sourcing

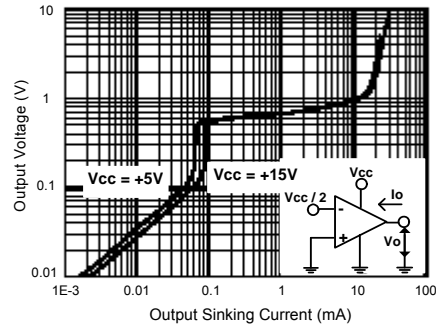

Figure 13. Output Characteristics Current Sinking

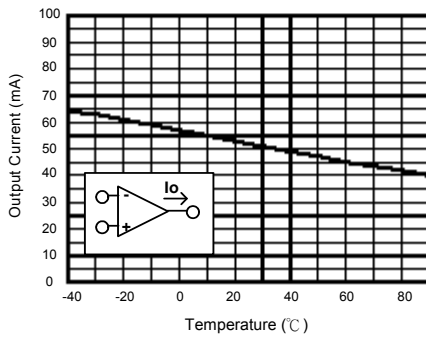

Figure 14. Current Limiting

Typical Applications

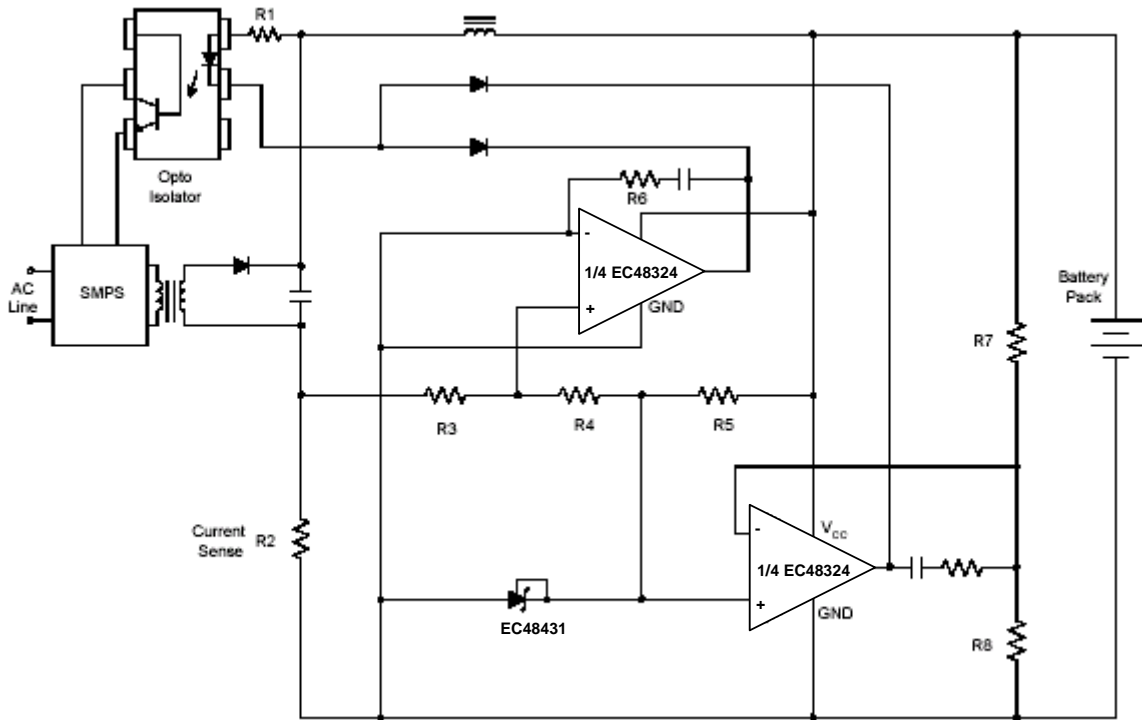

Figure 15. Battery Charger

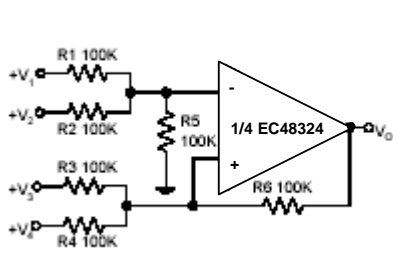

Figure 16. DC Summing Amplifier

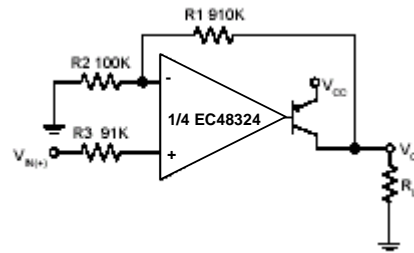

Figure 17. Power Amplifier

Typical Applications (Continued)

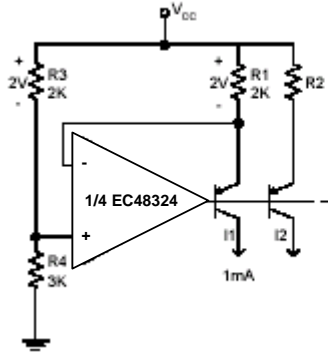

Figure 18. Fixed Current Sources

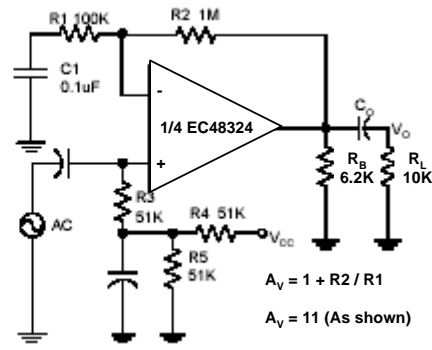

Figure 19. AC Coupled Non-Inverting Amplifier

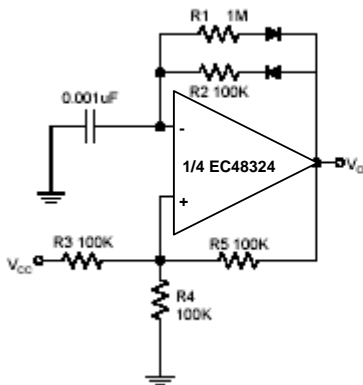

Figure 20. Pulse Generator

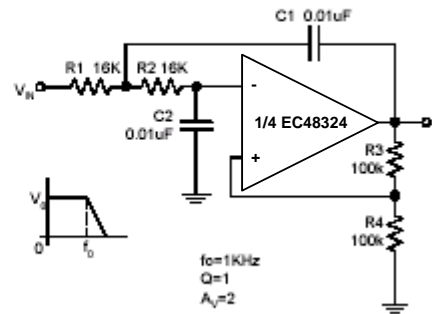
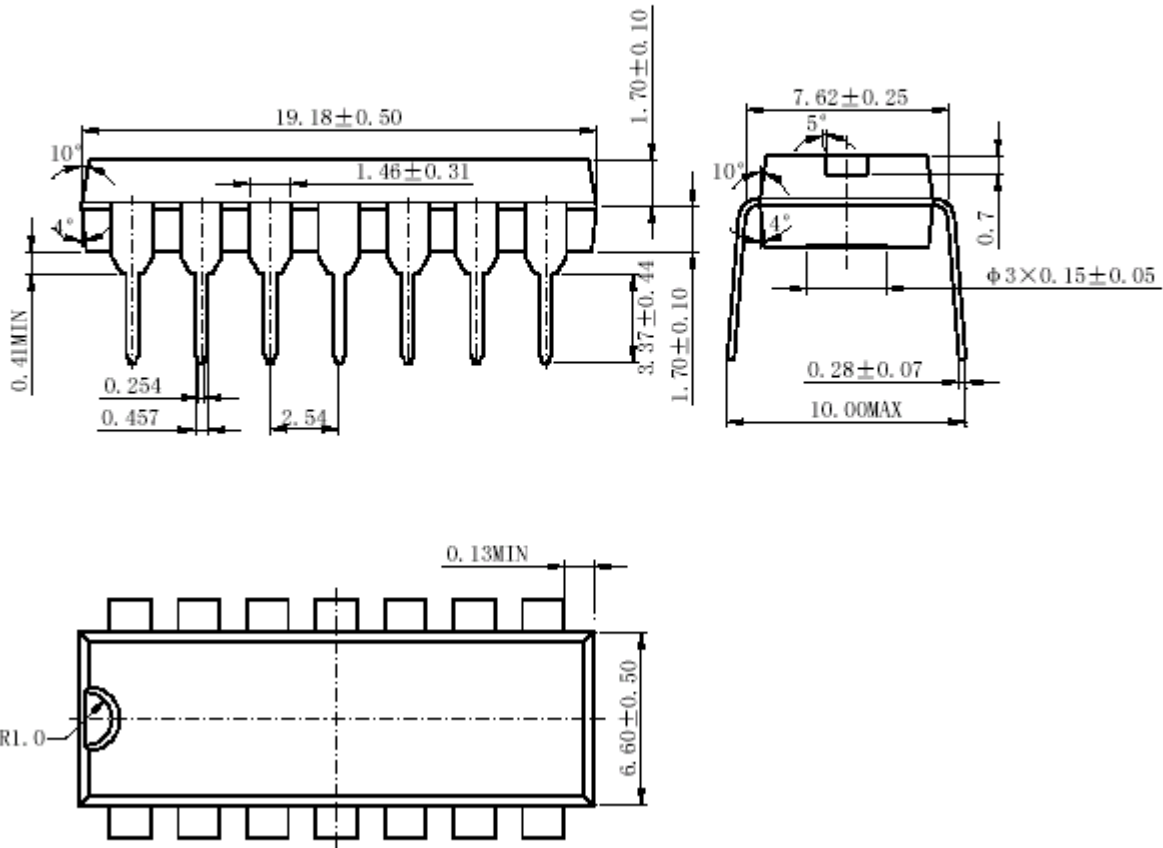

Figure 21. DC Coupled Low-Pass RC Active Filter

Mechanical Dimensions

DIP-14

Unit: mm



Mechanical Dimensions (Continued)

SOIC-14

Unit: mm

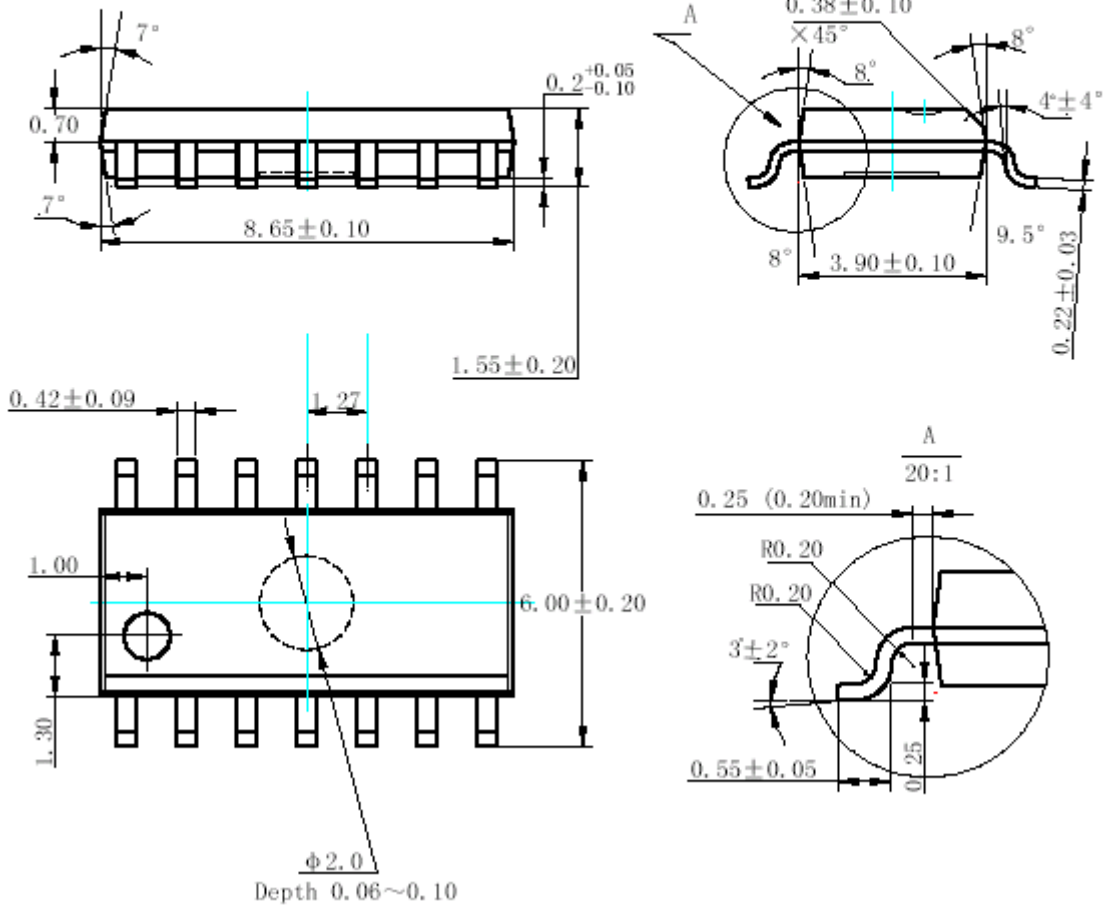

Mechanical Dimensions (Continued)

TSSOP-14

Unit : mm

