

SavantIC Semiconductor

Product Specification

Silicon NPN Power Transistors

2SD686

DESCRIPTION

- With TO-220C package
- Complement to type 2SB676
- DARLINGTON
- High DC current gain

APPLICATIONS

- Switching applications
- Hammer drive,pulse motor drive
- Power amplifier applications

PINNING

PIN	DESCRIPTION
1	Base
2	Collector;connected to mounting base
3	Emitter

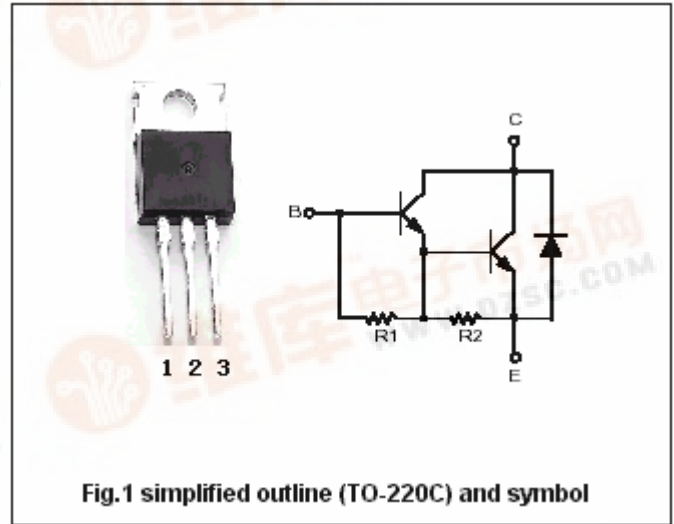

Fig.1 simplified outline (TO-220C) and symbol

Absolute maximum ratings(Ta=25°C)

SYMBOL	PARAMETER	CONDITIONS	VALUE	UNIT
V <sub>CBO</sub>	Collector-base voltage	Open emitter	100	V
V <sub>CEO</sub>	Collector-emitter voltage	Open base	80	V
V <sub>EBO</sub>	Emitter-base voltage	Open collector	5	V
I <sub>C</sub>	Collector current		4	A
P <sub>C</sub>	Collector power dissipation	T <sub>C</sub> =25°C	30	W
T <sub>j</sub>	Junction temperature		150	°C
T <sub>stg</sub>	Storage temperature		-50~150	°C

## Silicon NPN Power Transistors

## 2SD686

## CHARACTERISTICS

T<sub>j</sub>=25°C unless otherwise specified

SYMBOL	PARAMETER	CONDITIONS	MIN	TYP.	MAX	UNIT
V <sub>(BR)CEO</sub>	Collector-emitter breakdown voltage	I <sub>C</sub> =10mA; I <sub>B</sub> =0	80			V
V <sub>CEsat</sub>	Collector-emitter saturation voltage	I <sub>C</sub> =3A; I <sub>B</sub> =6mA			1.5	V
V <sub>BEsat</sub>	Base-emitter saturation voltage	I <sub>C</sub> =3A; I <sub>B</sub> =6mA			2.0	V
I <sub>CBO</sub>	Collector cut-off current	V <sub>CB</sub> =100V; I <sub>E</sub> =0			20	μA
I <sub>EBO</sub>	Emitter cut-off current	V <sub>EB</sub> =5V; I <sub>C</sub> =0			2.5	mA
h <sub>FE-1</sub>	DC current gain	I <sub>C</sub> =1A; V <sub>CE</sub> =2V	2000			
h <sub>FE-2</sub>	DC current gain	I <sub>C</sub> =3A; V <sub>CE</sub> =2V	1000			

## Switching times

t <sub>on</sub>	Turn-on time	I <sub>B1</sub> =-I <sub>B2</sub> =6mA V <sub>CC</sub> =30V; R <sub>L</sub> =10Ω		0.2		μs
t <sub>s</sub>	Storage time			1.5		μs
t <sub>f</sub>	Fall time			0.6		μs

Silicon NPN Power Transistors

2SD686

PACKAGE OUTLINE

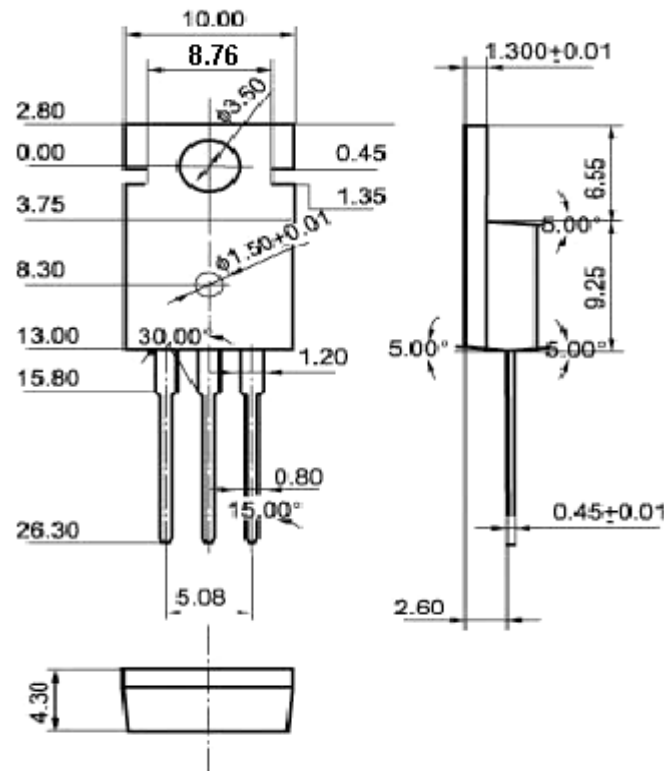

Fig.2 Outline dimensions (unindicated tolerance:±0.10mm)