

isc Silicon PNP Power Transistor

BD202/204

DESCRIPTION

- Collector-Emitter Breakdown Voltage-
: $V_{(BR)CEO} = -45V(\text{Min})$ - BD202
-60V(Min)- BD204
- Complement to Type BD201/203

APPLICATIONS

- Designed for use in hi-fi equipment delivering an output of 15 to 15 W into a 4 Ω or 8 Ω load.

ABSOLUTE MAXIMUM RATINGS($T_a=25^\circ\text{C}$)

SYMBOL	PARAMETER	VALUE	UNIT	
V_{CBO}	Collector-Base Voltage	BD202	-60	V
		BD204	-60	
V_{CEO}	Collector-Emitter Voltage	BD202	-45	V
		BD204	-60	
V_{EBO}	Emitter-Base Voltage	-5	V	
I_C	Collector Current-Continuous	-8	A	
I_{CM}	Collector Current-Peak $t_p \leq 10\text{ms}$	-12	A	
I_{CSM}	Collector Current-Peak $t_p \leq 2\text{ms}$	-25	A	
I_B	Base Current	-3	A	
P_C	Collector Power Dissipation @ $T_C=25^\circ\text{C}$	60	W	
T_J	Junction Temperature	150	$^\circ\text{C}$	
T_{stg}	Storage Temperature Range	-65~150	$^\circ\text{C}$	

THERMAL CHARACTERISTICS

SYMBOL	PARAMETER	MAX	UNIT
$R_{th\ j-c}$	Thermal Resistance, Junction to Case	2.08	$^\circ\text{C/W}$
$R_{th\ j-a}$	Thermal Resistance, Junction to Ambient	70	$^\circ\text{C/W}$

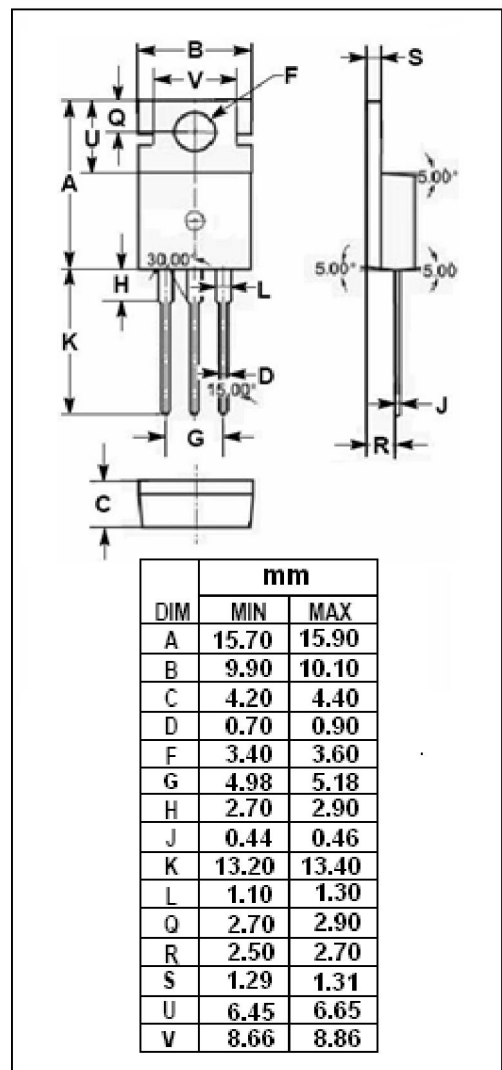
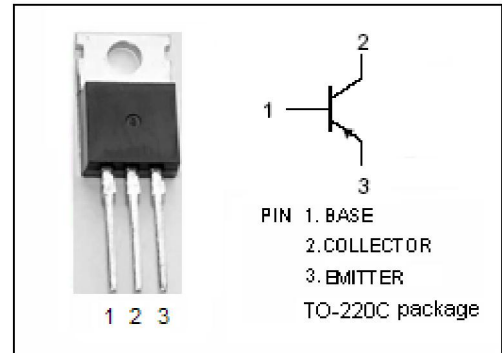

isc Silicon PNP Power Transistor

BD202/204

ELECTRICAL CHARACTERISTICS

 $T_C=25^\circ\text{C}$ unless otherwise specified

SYMBOL	PARAMETER		CONDITIONS	MIN	MAX	UNIT
$V_{(BR)CEO}$	Collector-Emitter Breakdown Voltage	BD202	$I_C = -0.2\text{A}; I_B = 0$	-45		V
		BD204		-60		
$V_{(BR)CBO}$	Collector-Base Breakdown Voltage		$I_C = -1\text{mA}; I_E = 0$	-60		V
$V_{(BR)EBO}$	Emitter-Base Breakdown Voltage		$I_E = -1\text{mA}; I_C = 0$	-5		V
$V_{CE(sat)-1}$	Collector-Emitter Saturation Voltage		$I_C = -3\text{A}; I_B = -0.3\text{A}$		-1.0	V
$V_{CE(sat)-2}$	Collector-Emitter Saturation Voltage		$I_C = -6\text{A}; I_B = -0.6\text{A}$		-1.5	V
$V_{BE(sat)}$	Base-Emitter Saturation Voltage		$I_C = -6\text{A}; I_B = -0.6\text{A}$		-2.0	V
$V_{BE(on)}$	Base-Emitter On Voltage		$I_C = -3\text{A}; V_{CE} = -2\text{V}$		-1.5	V
I_{CEO}	Collector Cutoff Current		$V_{CE} = -30\text{V}; I_B = 0$		-0.2	mA
I_{CBO}	Collector Cutoff Current		$V_{CB} = -40\text{V}; I_E = 0; T_J = 150^\circ\text{C}$		-1.0	mA
I_{EBO}	Emitter Cutoff Current		$V_{EB} = -5\text{V}; I_C = 0$		-0.5	mA
h_{FE}	DC Current Gain	BD202	$I_C = -3\text{A}; V_{CE} = -2\text{V}$	30		
		BD204	$I_C = -2\text{A}; V_{CE} = -2\text{V}$			
f_T	Current-Gain—Bandwidth Product		$I_C = -0.3\text{A}; V_{CE} = -3\text{V}; f_{test} = 1.0\text{MHz}$	7.0		MHz

Switching Times

t_{on}	Turn-On Time	$I_C = -2\text{A}; I_{B1} = -I_{B2} = -0.2\text{A}$	1	μs
t_{off}	Turn-Off Time		2	μs