

FK-180SH



Carbon-brush motors

OUTPUT : 0.3W~14W (APPROX)

WEIGHT : 32g (APPROX)

Typical Applications Home Appliances : Electric Shaver / Tooth Brush
Office Automation Equipment : Printer

MODEL	VOLTAGE		NO LOAD		AT MAXIMUM EFFICIENCY				STALL			
	OPERATING RANGE	NOMINAL	SPEED r/min	CURRENT A	SPEED r/min	CURRENT A	TORQUE mN-m	TORQUE g-cm	OUTPUT W	TORQUE mN-m	TORQUE g-cm	CURRENT A
FK-180SH-09450	12~24	12V CONSTANT	4400	0.021	3500	0.082	1.33	13.6	0.49	6.54	67	0.32
FK-180SH-17140 (*)	6~12	6V CONSTANT	7800	0.085	6390	0.39	2.04	20.8	1.36	11.3	115	1.75

(*) CCW shifted commutation (CCW+)

DIRECTION OF ROTATION

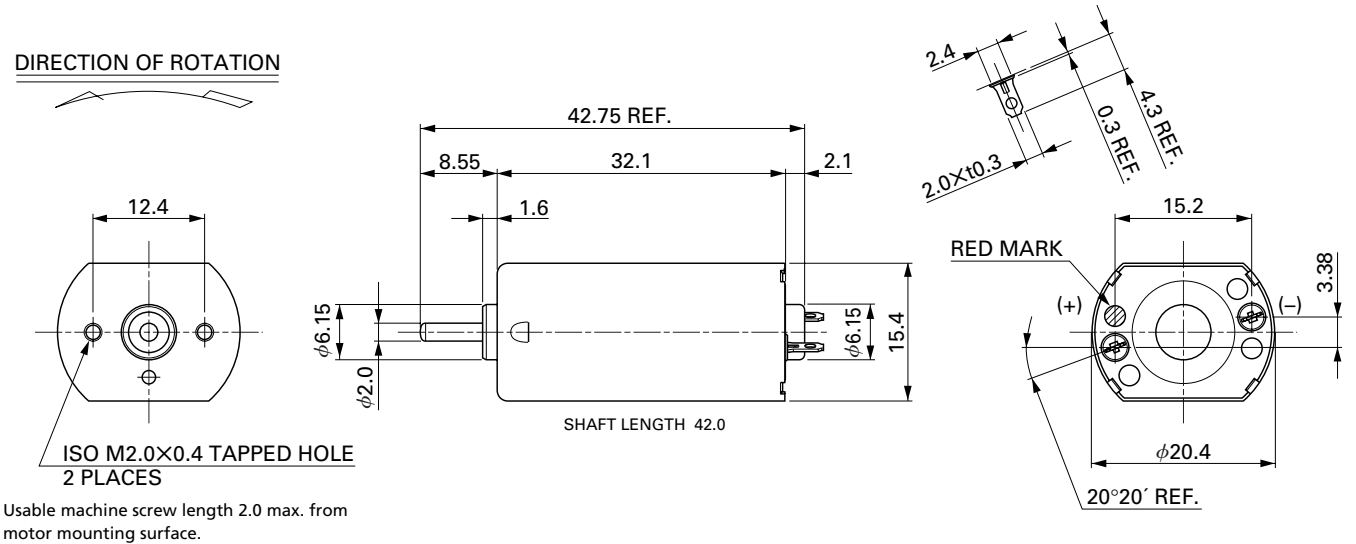

FK-180SH-09450 12.0V

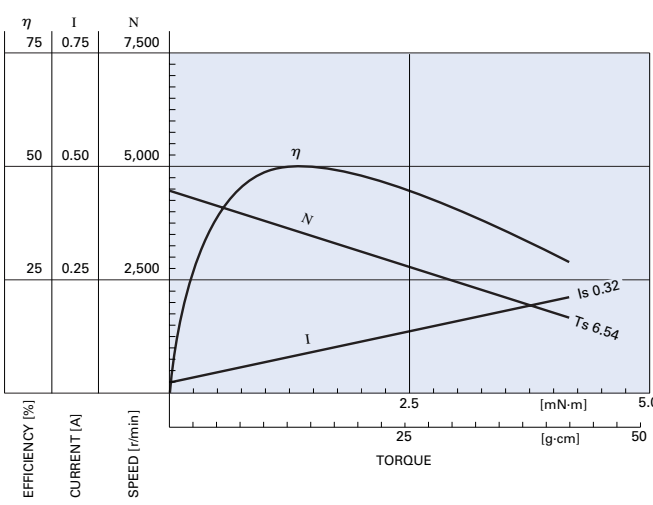

FK-180SH-17140 6.0V

