

**TV VERTICAL DEFLECTION BOOSTER**

ADVANCE DATA

- POWER AMPLIFIER
- FLYBACK GENERATOR (105V PEAK)
- THERMAL PROTECTION
- CURRENT LIMITED TO GND

**DESCRIPTION**

Designed for Monitors and high performance TVs, the TDA8179 vertical deflection booster delivers fly-back voltages up to 105V.

The TDA8179 operates with supplies up to 50V and provides up to 2App output current to drive to yoke.

The TDA8179 is offered in HEPTAWATT package.

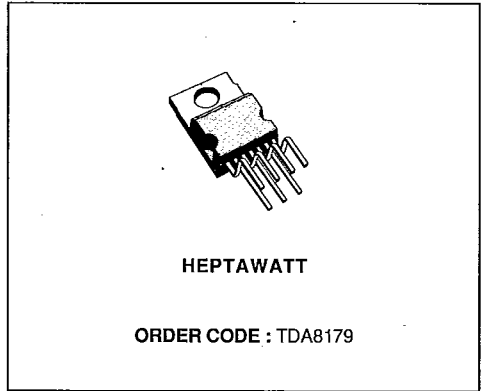

**BLOCK DIAGRAM**

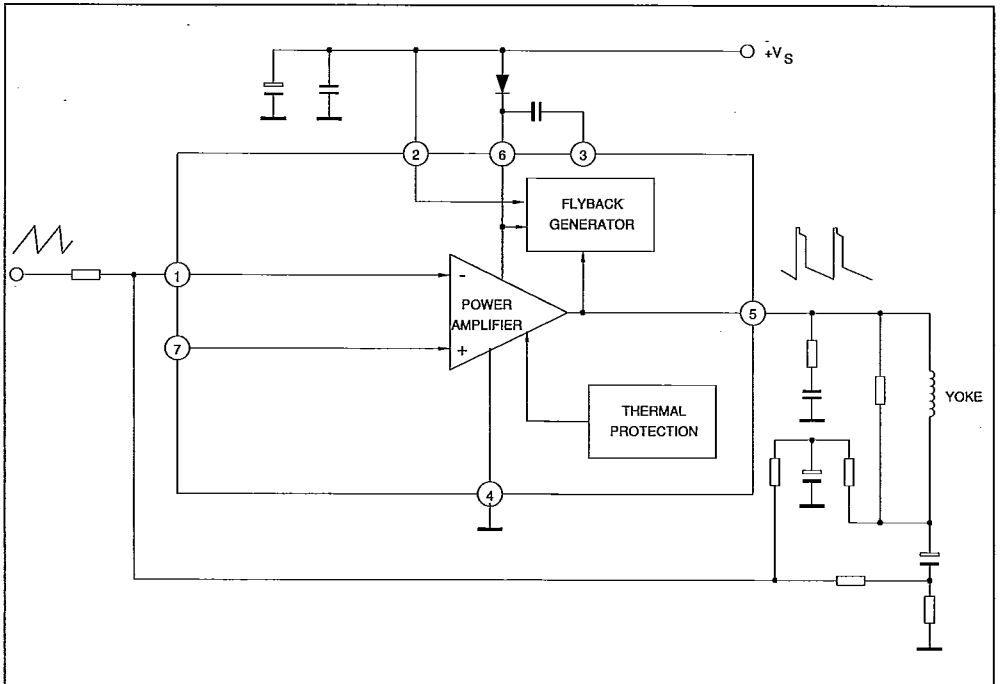

PIN CONNECTION (top view)

S G S-THOMSON

30E D

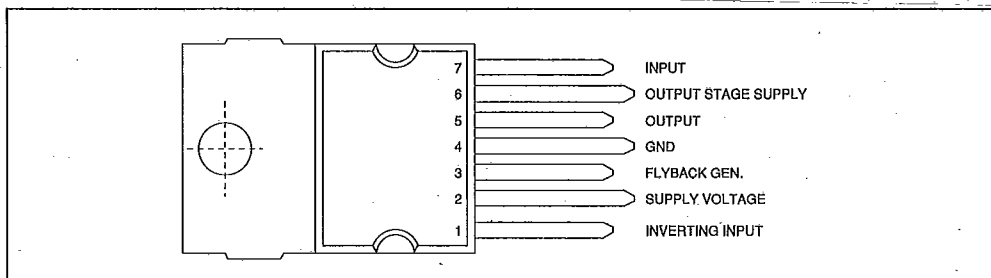

## APPLICATION CIRCUIT

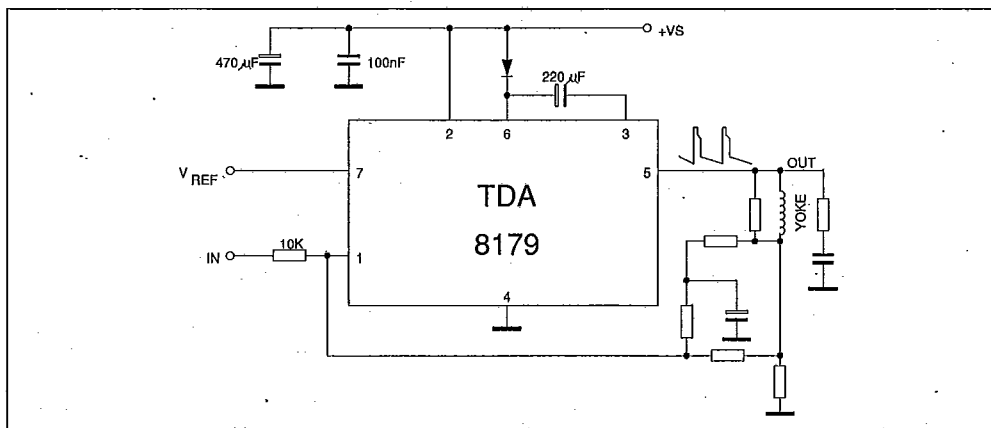

S G S-THOMSON

30E D

## ABSOLUTE MAXIMUM RATINGS

Symbol	Parameter	Value	Unit
$V_s$	Supply Voltage (pin 2)	50	V
$V_5, V_6$	Flyback Peak Voltage	105	V
$V_1, V_7$	Amplifier Input Voltage	+ $V_s$	
$I_O$	Output Peak Current (non repetitive, $t = 2\text{ms}$ )	2	A
$I_O$	Output Peak Current at $f = 50$ or $60\text{Hz}$ $t \leq 10\mu\text{s}$	2	A
$I_O$	Output Peak Current at $f = 50$ or $60\text{Hz}$ $t > 10\mu\text{s}$	1.8	A
$I_3$	Pin 3 DC at $V_5 < V_2$	100	mA
$I_3$	Pin 3 Peak Flyback Current at $f = 50$ or $60\text{Hz}$ , $t_{fly} \leq 1.5\text{ms}$	1.8	A
$P_{tot}$	Total Power Dissipation at $T_{case} = 70^\circ\text{C}$	20	W
$T_{stg}$	Storage Temperature	- 40 to 150	$^\circ\text{C}$
$T_j$	Junction Temperature	0 to 150	$^\circ\text{C}$

## THERMAL DATA

$R_{th J-C}$	Junction-case Thermal Resistance	Max	4	$^\circ\text{C/W}$
--------------	----------------------------------	-----	---	--------------------

## ELECTRICAL CHARACTERISTICS

( $V_7 = 2.2\text{V}$ ,  $V_s = 48\text{V}$ ,  $T_{amb} = 25^\circ\text{C}$ , unless otherwise specified) (refer to the test circuits)

Symbol	Parameter	Test Conditions	Min.	Typ.	Max.	Unit
$V_s$	Operating Supply Voltage Range		10		48	V
$I_2$	Pin 2 Quiescent Current	$I_3 = 0$ $I_5 = 0$		10	20	mA
$I_6$	Pin 6 Quiescent Current	$I_3 = 0$ $I_5 = 0$		20	40	mA
$I_1$	Amplifier bias Current	$V_1 = 1\text{V}$		- 0.2	- 1	$\mu\text{A}$
$V_{3L}$	Scanning Voltage	$I_3 = 20\text{mA}$		1.3	1.8	V
$V_5$	Quiescent Output Voltage	$V_s = 48\text{V}$ $R_a = 3.9\text{K}\Omega$		24.2		V
		$V_s = 35\text{V}$ $R_a = 5.6\text{K}\Omega$		17.5		
$V_{5L}$	Output Saturation Voltage to GND	$I_5 = 1\text{A}$		1.2	1.5	V
$V_{5H}$	Output Saturation Voltage to Supply	- $I_5 = 1\text{A}$		2.2	2.8	V
$V_{D5-6}$	Diode Forward Voltage between Pins 5-6	$I_D = 1\text{A}$		1.5		V
$V_{D3-2}$	Diode Forward Voltage between Pins 3-2	$I_D = 1\text{A}$		1.5		V
$R_1$	Input Resistance			200		$\text{K}\Omega$
$T_j$	Junction Temperature for Thermal Shutdown			140		$^\circ\text{C}$

Figure 1 : DC Test Circuits.

Figure 1a : Measurement of  $I_1$  ;  $I_2$  ;  $I_6$ .

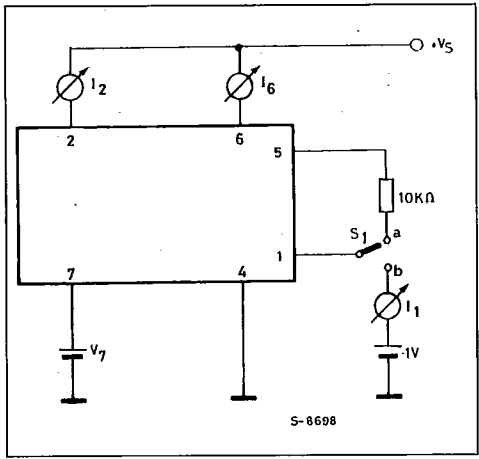

S1 : (a)  $I_2$  and  $I_6$  ; (b)  $I_1$ .

Figure 1b : Measurement of  $V_{5H}$ .

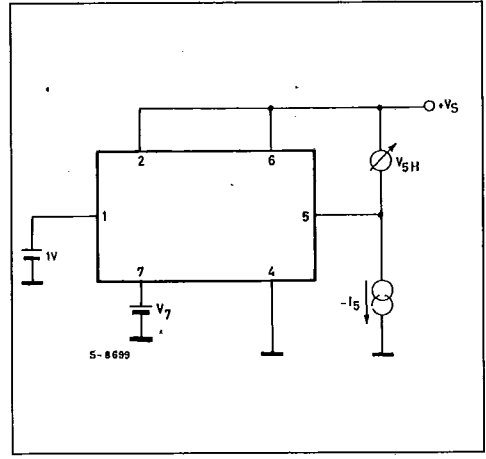
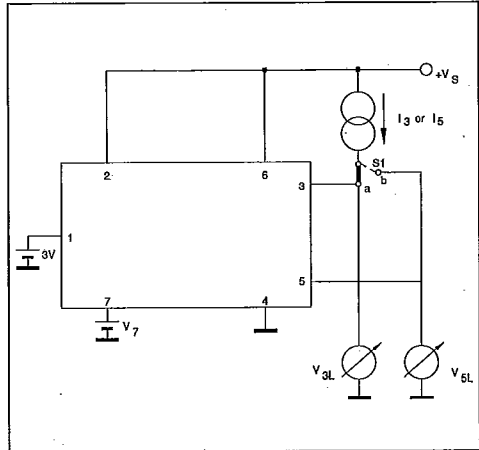
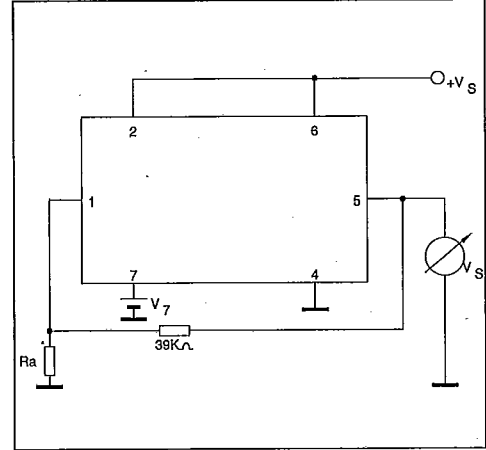

Figure 1c : Measurement of  $V_{3L}$  ;  $V_{5L}$ .



S1 : (a)  $V_{3L}$  ; (b)  $V_{5L}$ .

Figure 1d : Measurement of  $V_5$ .



SGS-THOMSON

30E D

Figure 2 : SOA of Each Output Power Transistor at 25°C amb.

