

OVERVIEW

The SM5301BS is a video filter LSI with buffered outputs for VESA-standard ATSC digital TV. The filter employs a 5-order Butterworth lowpass filter configuration. The filter characteristics have been optimized for minimal overshoot and flat group delay, it has a variable cutoff frequency and guaranteed output buffer-stage channel gain difference and phase difference values. It has also filter through mode.

FEATURES

- Supply voltage: 5V ± 10%
- VESA-standard ATSC digital TV RGB/YUV video filters
- RGB/YUV switching multiplexer function
- Sync tip clamp input
- 0dB, 6dB gain switching function (input-to-output AC signal gain)
- Channel-to-channel gain difference: 0.5dB (± 5% supply voltage variation)
- Channel-to-channel phase difference: 3.5 degree
- Output signal harmonic distortion (all channels): 1.5%
- Cutoff frequency: 5 to 37MHz variable
- Filter through mode (passband frequency is 46MHz, when gain is 6dB)
- Package: 28-pin HSOP (Pb free)

APPLICATIONS

- Set-top boxes
- Digital television
- DVD players

ORDERING INFORMATION

Device	Package
SM5301BS	28-pin HSOP

PINOUT

(Top view)

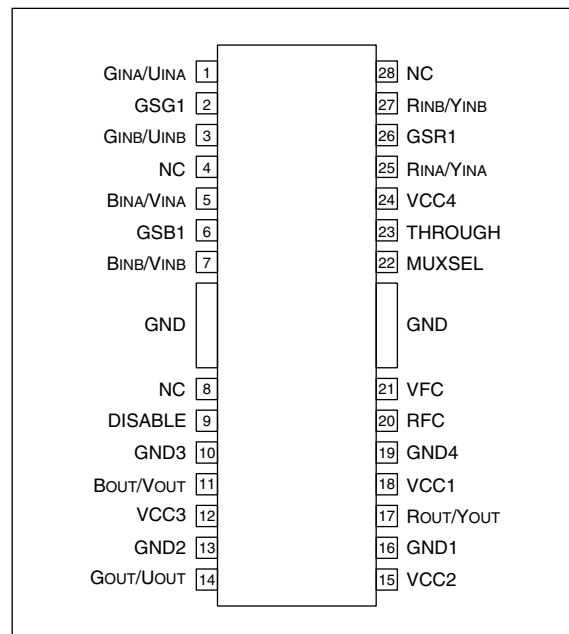

PACKAGE DIMENSIONS

(Unit: mm)

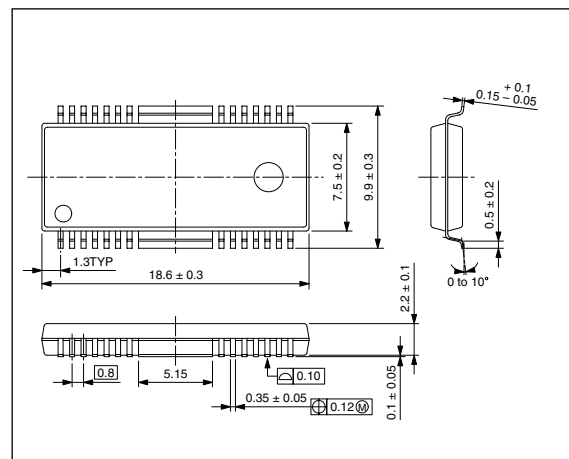

BLOCK DIAGRAM

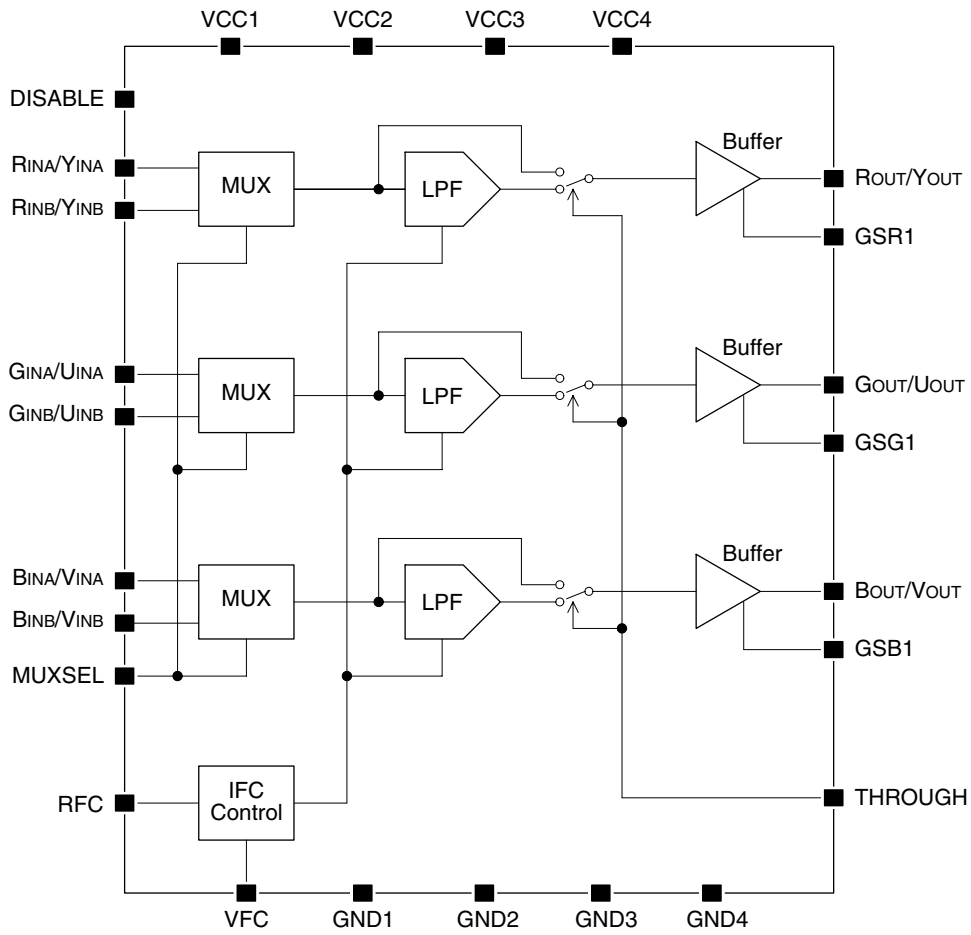

Note. Power supply pin distinction
 VCC1, GND1: R/Y block
 VCC2, GND2: G/U block
 VCC3, GND3: B/V block
 VCC4, GND4: IFCCONT block, and logic input control block

PIN DESCRIPTION

Number	Name	I/O ¹	Description
1	G _{INA} /U _{INA}	I	Analog G _{INA} or U _{INA} signal input
2	GSG1	Ipu	G _{OUT} /U _{OUT} output buffer gain set input
3	G _{INB} /U _{INB}	I	Analog G _{INB} or U _{INB} signal input
4	NC	–	No connection (leave open or connect to ground)
5	B _{INA} /V _{INA}	I	Analog B _{INA} or V _{INA} signal input
6	GSB1	Ipu	B _{OUT} /V _{OUT} output buffer gain set input
7	B _{INB} /V _{INB}	I	Analog B _{INB} or V _{INB} signal input
8	NC	–	No connection (leave open or connect to ground)
9	DISABLE	Ipd	Power save function L: Enable H: Disable (Output pins: R _{OUT} /Y _{OUT} , G _{OUT} /U _{OUT} , and B _{OUT} /V _{OUT} are high impedance.)
10	GND3	–	Analog ground
11	B _{OUT} /V _{OUT}	O	B/V signal output
12	VCC3	–	Analog 5V supply
13	GND2	–	Analog ground
14	G _{OUT} /U _{OUT}	O	G/U signal output
15	VCC2	–	Analog 5V supply
16	GND1	–	Analog ground
17	R _{OUT} /Y _{OUT}	O	R/Y signal output
18	VCC1	–	Analog 5V supply
19	GND4	–	Analog ground
20	RFC	–	LPF (lowpass filter) cutoff frequency setting resistor connection
21	VFC	I	LPF (lowpass filter) cutoff frequency setting voltage input
22	MUXSEL	Ipd	Input select signal L: × _{INA} pin select H: × _{INB} pin select
23	THROUGH	Ipd	Filter mode select pin L: Filter mode H: Filter through mode
24	VCC4	–	Analog 5V supply
25	R _{INA} /Y _{INA}	I	Analog R _{INA} or Y _{INA} signal input
26	GSR1	Ipu	R _{OUT} /Y _{OUT} output buffer gain set input
27	R _{INB} /Y _{INB}	I	Analog R _{INB} or Y _{INB} signal input
28	NC	–	No connection (leave open or connect to ground)

1. I: input pin, Ipd: input pin with pull-down resistor, Ipu: input pin with pull-up resistor, o: output pin

SPECIFICATIONS

Absolute Maximum Ratings

Parameter	Symbol	Rating	Unit
Supply voltage range	V_{CC}	- 0.3 to 7.0	V
Supply voltage deviation ¹	ΔV_{CC}	± 0.1	V
Storage temperature range	T_{stg}	- 55 to + 125	°C
Power dissipation 1 ²	P_{D1}	1.0	W
Power dissipation 2 ³	P_{D2}	0.9	W
Junction temperature	T_j	125	°C

1. Supply voltage deviation of each power supply pin. Supply the power to VCC1 to VCC4 pin, simultaneously.
2. When mounted on a substrate: mounted on a 111 × 80 × 1.6mm glass-epoxy substrate with 90% copper (Cu) wiring factor, 0m/s air flow, $\theta_{jc} = 52^\circ\text{C/W}$, and $T_a = -25$ to 70°C .
3. When mounted on a substrate: mounted on a 111 × 80 × 1.6mm glass-epoxy substrate with 90% copper (Cu) wiring factor, 0m/s air flow, $\theta_{jc} = 52^\circ\text{C/W}$, and $T_a = 70$ to 80°C .

Recommended Operating Conditions

Parameter	Symbol	Rating	Unit
Supply voltage range	V_{CC}	4.5 to 5.5	V
Operating ambient temperature	T_a	- 25 to 85	°C

Electrical Characteristics

Input and Output Characteristics

$V_{CC} = 4.5$ to $5.5V$, $T_a = -25$ to $85^\circ C$ unless otherwise noted. Refer to "Measurement Circuit".

Parameter	Symbol	Condition	Rating			Unit	Test level
			min	typ	max		
Supply current 1	I_{CC1}	$V_{CC} = 5.5V$, $R_{FC} = 820\Omega$ to GND, $V_{FC} = 0.2V$, DISABLE = "L"	70	100	130	mA	I
Supply current 2	I_{CC2}	$V_{CC} = 5.5V$, $R_{FC} = 820\Omega$ to GND, $V_{FC} = 1.6V$, DISABLE = "L"	90	120	160	mA	I
Supply current 3	I_{CC3}	$V_{CC} = 5.5V$, $R_{FC} = 820\Omega$ to GND, $V_{FC} = 0.2V$, DISABLE = "H"	1	2.5	5	mA	I
Output gain error 1	ΔA_{V1}	Gain = 0dB/6dB, $V_{CC} = 4.75$ to $5.25V$, $T_a = 0$ to $70^\circ C$	-	-	± 0.5	dB	I
Output gain error 2	ΔA_{V2}	Gain = 0dB/6dB, $T_a = -25$ to $85^\circ C$	-	-	± 1	dB	I
Maximum output voltage	V_{out}	$R_L = 75\Omega$ to GND, Gain = 6dB	2.4	-	-	Vp-p	I
DISABLE-mode input impedance (pull-down)	R_{IN1}	R_{INA}/Y_{INA} , R_{INB}/Y_{INB} , G_{INA}/U_{INA} , G_{INB}/U_{INB} , B_{INA}/V_{INA} , B_{INB}/V_{INB}	40	50	60	k Ω	I
Clamp response time	T_{clamp}	Time for 90% output signal change for 10mV input signal, $C_{IN} = 0.1\mu F$	-	8	-	ms	II
Maximum input amplitude	V_I	AC coupling input, Gain = 6dB	-	-	1.4	Vp-p	I
Maximum overshoot	V_{OS}	2Vp-p pulse output	-	10	-	%	II
Maximum load capacitance	C_L	B_{OUT}/V_{OUT} , G_{OUT}/U_{OUT} , R_{OUT}/Y_{OUT}	-	-	15	pF	II
Output drive load	R_L	one load unit = 150Ω	-	-	2	load	I
Channel-to-channel gain difference	dG	Between R/G/B, fc/2 [Hz]	-	-	0.5	dB	I
Channel-to-channel phase difference	d ϕ	Between R/G/B, fc/2 [Hz]	-	3.5	-	degree	II
Output harmonic distortion	T_{HD}	$V_{out} = 2V_{p-p}$, $f = 1MHz$	-	1.5	-	%	II
Power supply rejection ratio	PSRR	$V_{CC} = 0.5V_{p-p}$, $f = 100kHz$	-	35	-	dB	II
Output short-circuit current	I_{SC}		-	-	100	mA	II
Logic HIGH-level input voltage 1	V_{IH1}	DISABLE, MUXSEL, THROUGH	2.5	-	-	V	I
Logic LOW-level input voltage 1	V_{IL1}	DISABLE, MUXSEL, THROUGH	-	-	1.0	V	I
Logic HIGH-level input voltage 2	V_{IH2}	GSB1, GSG1, GSR1	$V_{CC} - 0.5$	-	-	V	I
Logic LOW-level input voltage 2	V_{IL2}	GSB1, GSG1, GSR1	-	-	0.5	V	I
Logic pull-up resistance	R_{IN2}	GSB1, GSG1, GSR1	32	40	48	k Ω	I
Logic pull-down resistance	R_{IN3}	DISABLE, MUXSEL, THROUGH	40	50	60	k Ω	I

Filter Mode Characteristics

$V_{CC} = 4.5$ to $5.5V$, $T_a = -25$ to $85^\circ C$, THROUGH = Low, $V_I = 0.7V_{p-p}$ unless otherwise noted. Refer to “Measurement Circuit”.

Parameter	Symbol	Condition	Rating			Unit	Test level	
			min	typ	max			
Cutoff frequency adjustment range	F_C	$T_a=25^\circ C$ (see Figure 1-1)	5.8	–	37	MHz	I	
Cutoff frequency error	ΔF_C	$T_a = 25^\circ C$, $V_{CC} = 5.0V$	–	–	± 20	%	I	
4fc attenuation	f_{SB}	$f_{IN} \geq 4f_c$	–	50	–	dB	II	
Crosstalk	X_{TALK}	Between 2 channels with input $0.5V_{p-p}$ 1MHz	–	–47	–	dB	II	
Multiplexer crosstalk	X_{TALK}	Between MUX A–B with input $0.5V_{p-p}$ 1MHz	–	–49	–	dB	II	
Channel-to-channel group delay	T_{PD}	Each input = 500kHz	–	10	–	ns	II	
Group delay variation	ΔT_{PD1}	$F_c = 6.7MHz$ (500kHz)	to 3.58MHz	–	9	–	ns	II
			to 4.43MHz	–	15	–	ns	II
	ΔT_{PD2}	$F_c = 24MHz$ (500kHz)	to 3.58MHz	–	1	–	ns	II
			to 4.43MHz	–	1	–	ns	II
			to 10MHz	–	2	–	ns	II
	ΔT_{PD3}	$F_c = 36MHz$ (1MHz)	to 10MHz	–	0.5	–	ns	II
to 30MHz			–	5	–	ns	II	
VFC input voltage range	VFC	Filter mode, through mode	0.2	–	1.6	V	I	

Through Mode Characteristics

$V_{CC} = 5.0V$, $T_a = -25$ to $85^\circ C$, THROUGH = High, $V_I = 0.7V_{p-p}$ unless otherwise noted. Refer to “Measurement Circuit”.

Parameter	Symbol	Condition	Rating			Unit	Test level
			min	typ	max		
Cutoff frequency (6dB)	F_C	$T_a=25^\circ C$, Gain = 6dB, VFC = 1.6V, RFC=820 Ω	42	46	–	MHz	I
Cutoff frequency (0dB)	F_C	$T_a=25^\circ C$, Gain = 0dB, VFC = 1.6V, RFC=820 Ω	39	43	–	MHz	I
Crosstalk	X_{TALK}	Between 2 channels with input $0.5V_{p-p}$ 1MHz	–	–60	–	dB	II
Multiplexer crosstalk	X_{TALK}	Between MUX A–B with input $0.5V_{p-p}$ 1MHz	–	–60	–	dB	II

Test level

I : 100% of products tested at $T_a = +25^\circ C$.

II : Guaranteed as result of design and characteristics evaluation.

Measurement Circuit

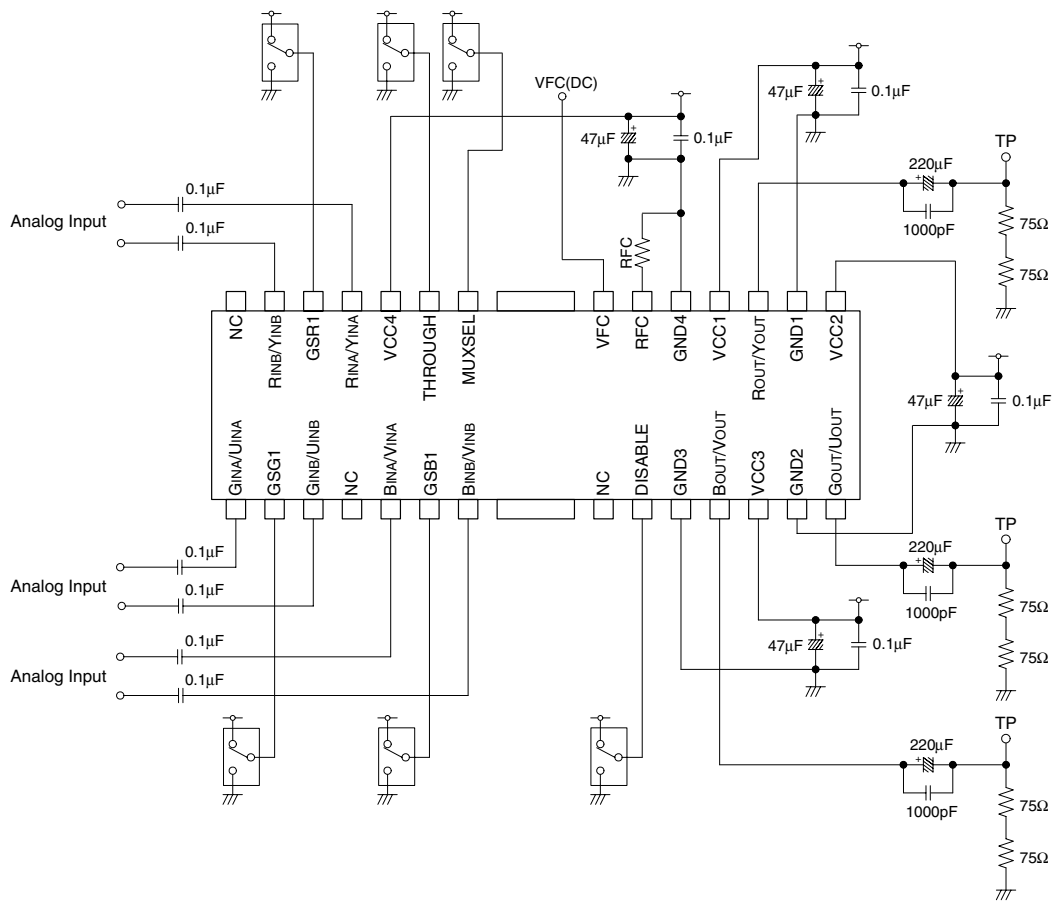

FUNCTION DESCRIPTION

Output Buffer Gain Control

GS×1 pin sets the output buffer gain.

GSR1, GSG1, GSB1	Gain [dB]
Low	0
High or Open	6

Cutoff Frequency Control (RFC and VFC)

Cutoff frequency (f_c) can be controlled by control current I_{fc} ($= VFC/RFC$) shown as Figure 1-1. And relation of f_c vs VFC at $RFC = 680\Omega$, 820Ω , $1k\Omega$ is shown as Figure 1-2.

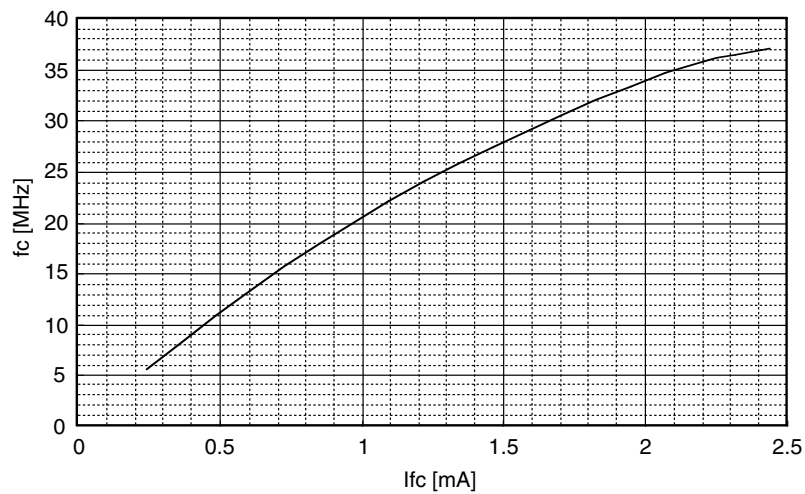

Figure 1-1. f_c vs. I_{fc}

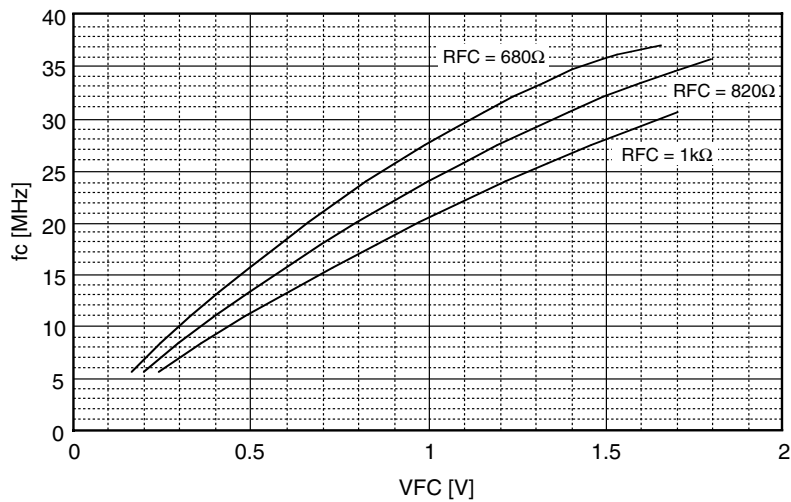

Figure 1-2. f_c vs. VFC

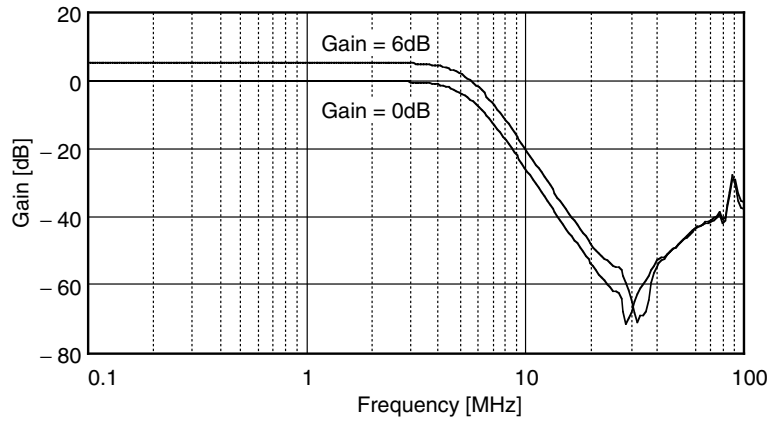

Figure 2-1. Filter characteristic (RFC = 820Ω, VFC = 0.2V)

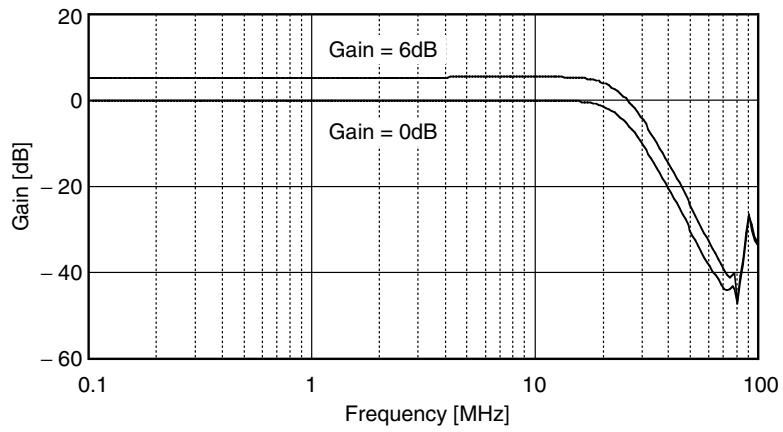

Figure 2-2. Filter characteristic (RFC = 820Ω, VFC = 1.0V)

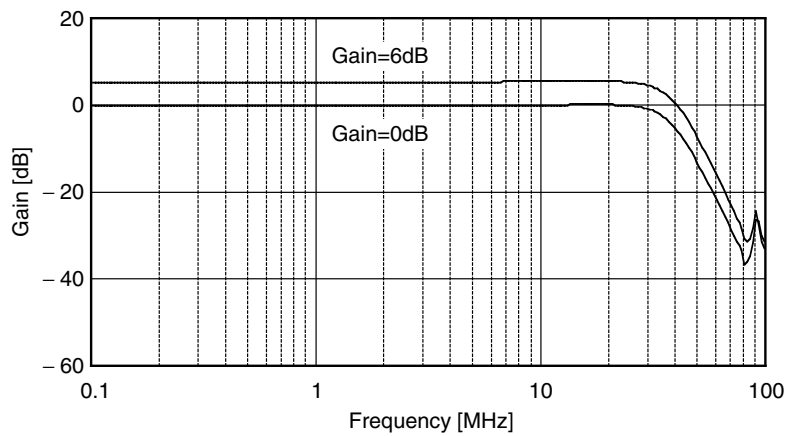

Figure 2-3. Filter characteristic (RFC = 820Ω, VFC = 1.6V)

Filter Through Mode

THROUGH pin sets the through mode. It functions only output buffer, and bypasses the LPF.

THROUGH	Filter mode/Through mode
Low or Open	Filter mode
High	Through mode

Frequency characteristics of through mode is shown as Figure 3 (VFC = 1.6V, RFC = 820Ω).

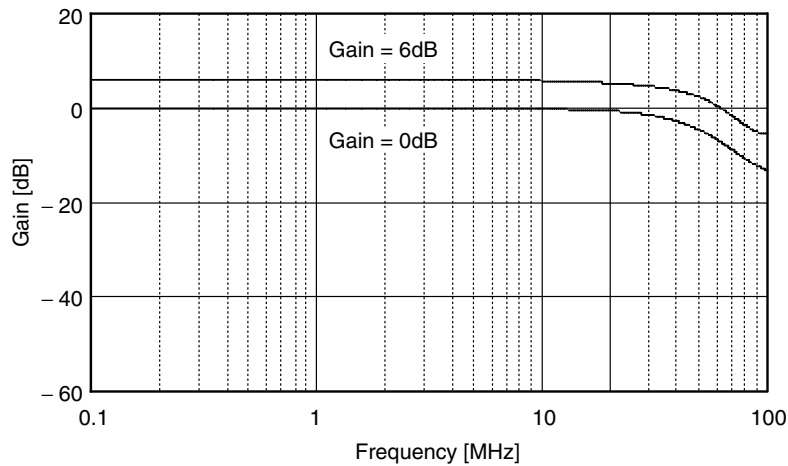

Figure 3. Through mode frequency characteristic

Analog Signal Input

Input Channel Selection

MUXSEL pin sets the analog input channel \times_{INA} or \times_{INB} .

MUXSEL	Analog input channel
Low or Open	\times_{INA}
High	\times_{INB}

Selected pins are connected to the internal synctip clamp circuit. Clamp voltage is 2.3V (typ).

BIAS Input

When input signal is color difference signal of component signal, BIAS input is suitable better than CLAMP input. Connect the resistors as Figure 4, it functions BIAS input.

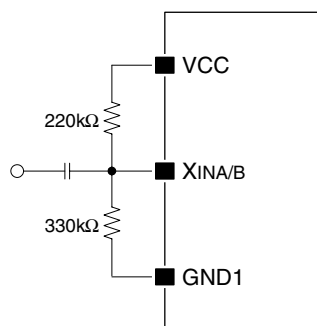
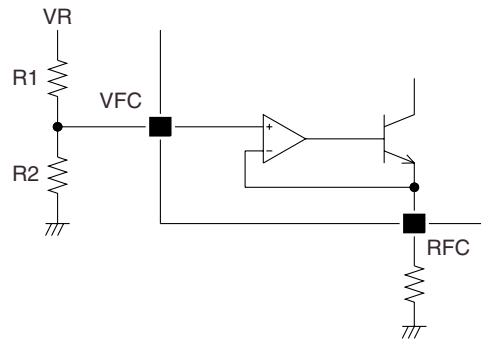

Figure 4. Resistor connection for BIAS input

Adjusting the Cutoff Frequency

Constant-voltage control 1

Cutoff frequency control using a reference voltage V_R generated by voltage divider formed by R_1 and R_2 .



Constant-voltage control 2

Cutoff frequency control by adjusting the resistance connected to RFC.

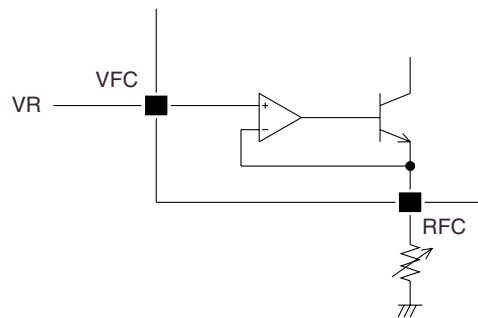

PWM control

Cutoff frequency control by smoothing the PWM signal, using R_1 and C_1 , input to VFC.

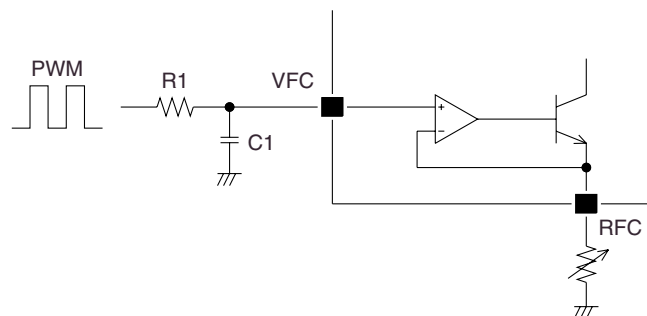

When $V_{FC} = 0.2V$ $V_{DD} = 3.3V$, 6% duty drive
 $V_{DD} = 5.0V$, 4% duty drive

When $V_{FC} = 1.6V$ $V_{DD} = 3.3V$, 48% duty drive
 $V_{DD} = 5.0V$, 32% duty drive

Note: The resistor connected to RFC can affect the cutoff frequency response, so a high-precision component should be used. It is recommended to set the RC filter cutoff frequency to $< 1/100f_c$ of the PWM waveform frequency.

Resistor switch control

The VFC voltage can be controlled using multi-logic voltage levels switching inputs to a voltage divider resistor network.

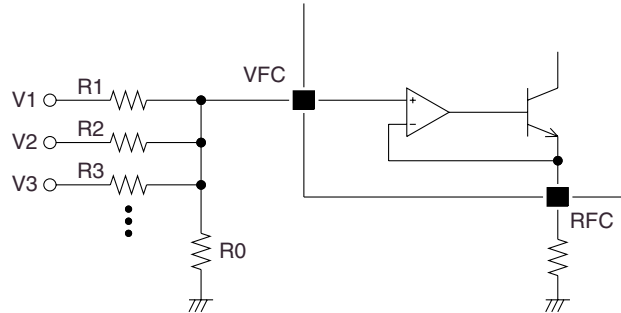

The VFC voltage is determined by the logic voltage (V1, V2, V3) and the corresponding voltage divider resistor network.

TYPICAL APPLICATION CIRCUITS

ATSC Digital TV Application

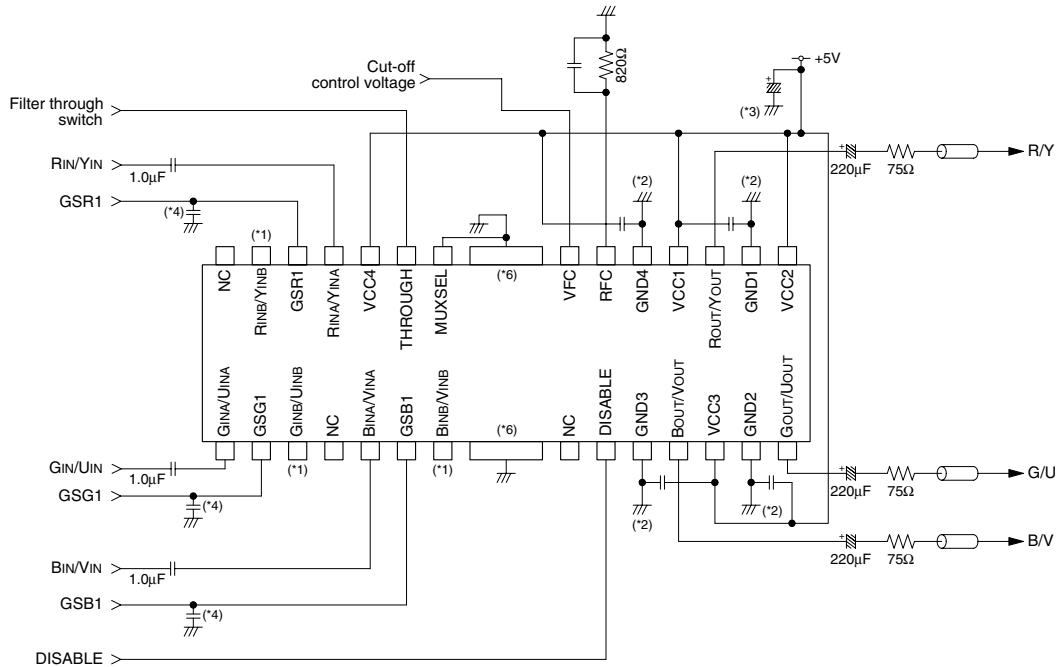

- (*1) Pins without an input signal, set by NUXSEL, should be left open or tied to GND.
- (*2) Connect $4 \times 0.1\mu\text{F}$ capacitor between the supply pins close to the IC.
- (*3) Connect a $47\mu\text{F}$ capacitor between the supply pins close to the IC.
- (*4) Connect a capacitor if an error occurs due to external noise for GSR1, GSG1, GSB1 pins. Also, if open-circuit, the internal impedance and external capacitance (C) form an RC network. When power is applied, the open-circuit potential rises with time constant $\tau = C \times 10\text{k}$ (sec).
- (*5) Printed circuit board supply wiring
- If the supply is used for other digital circuits, there is a possibility that noise will be introduced. Accordingly, these circuits should be connected to the application's analog supply.
 - Ground-plane wiring should be performed, as much as possible, to provide low GND line impedance.
 - If ground-plane wiring up to the GND pins is difficult, the ground plane should be as close to the IC as possible with a separate wire to each GND pin.
- (*6) The tab (radiation fin) between 7 pin and 8 pin and between 21 pin and 22 pin should be connected to the large ground plane as much as possible for radiation.

Input Capacitor and High Pass Filter Cutoff Frequency

The capacitor connected to pins R_{INA}/Y_{INA} , R_{INB}/Y_{INB} , G_{INA}/U_{INB} , G_{INB}/U_{INB} , B_{INA}/V_{INA} , and B_{INB}/V_{INB} forms a highpass filter (HPF) with the internal impedance.

The HPF cutoff frequency is given by the following equation.

$$f_c = \frac{1}{2\pi CR}$$

(C: input capacitance, R: signal input impedance = $9.3\text{k}\Omega$ (typ))

2-load Output Connection

R_{OUT}/Y_{OUT} output 2-load connection (similarly for G_{OUT}/U_{OUT}, B_{OUT}/V_{OUT} outputs)

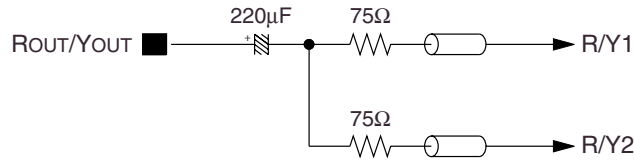

Digital TV Receiver and HDTV Decoder Box

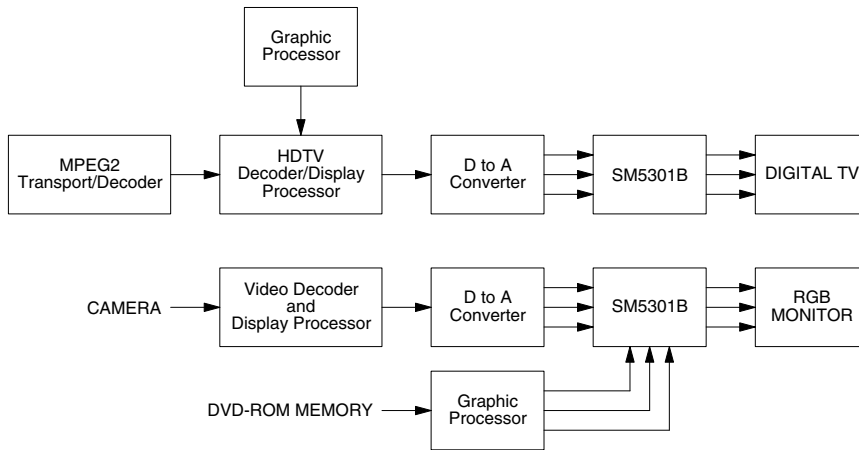

Plasma Display Panel

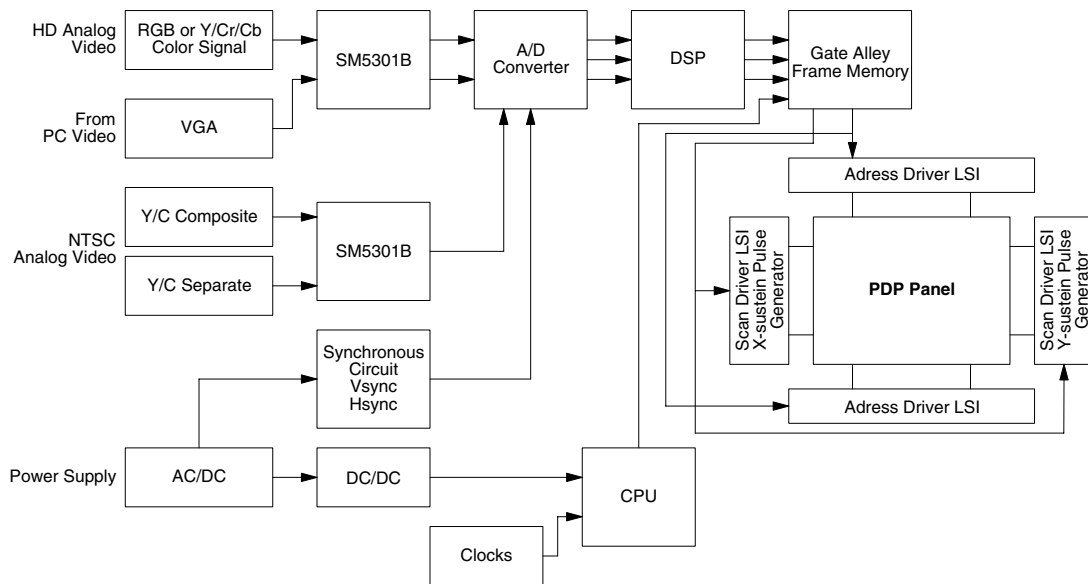

Please pay your attention to the following points at time of using the products shown in this document.

The products shown in this document (hereinafter "Products") are not intended to be used for the apparatus that exerts harmful influence on human lives due to the defects, failure or malfunction of the Products. Customers are requested to obtain prior written agreement for such use from SEIKO NPC CORPORATION (hereinafter "NPC"). Customers shall be solely responsible for, and indemnify and hold NPC free and harmless from, any and all claims, damages, losses, expenses or lawsuits, due to such use without such agreement. NPC reserves the right to change the specifications of the Products in order to improve the characteristic or reliability thereof. NPC makes no claim or warranty that the contents described in this document dose not infringe any intellectual property right or other similar right owned by third parties. Therefore, NPC shall not be responsible for such problems, even if the use is in accordance with the descriptions provided in this document. Any descriptions including applications, circuits, and the parameters of the Products in this document are for reference to use the Products, and shall not be guaranteed free from defect, inapplicability to the design for the mass-production products without further testing or modification. Customers are requested not to export or re-export, directly or indirectly, the Products to any country or any entity not in compliance with or in violation of the national export administration laws, treaties, orders and regulations. Customers are requested appropriately take steps to obtain required permissions or approvals from appropriate government agencies.

The logo for SEIKO NPC CORPORATION, consisting of the letters 'NPC' in a bold, black, sans-serif font.

SEIKO NPC CORPORATION

1-9-9, Hatchobori, Chuo-ku,
Tokyo 104-0032, Japan
Telephone: +81-3-5541-6501
Facsimile: +81-3-5541-6510
<http://www.npc.co.jp/>
Email: sales@npc.co.jp

NC0208BE 2006.04