

2453, 2454, 2455

AUTOMOTIVE LAMP MONITORS

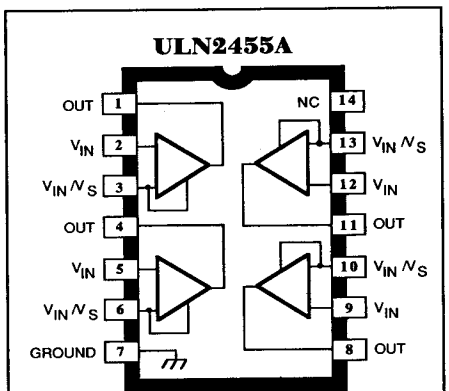

Dwg. PS-013

ABSOLUTE MAXIMUM RATINGS at +25°C Free-Air Temperature

Supply Voltage, V_{CC}	30 V
Peak Supply Voltage, $V_{CC}(100\text{ ms})$...	80 V
Peak Reverse Voltage, V_R	30 V
Output Current, I_{OUT}	35 mA
Package Power Dissipation, P_D ..	See Graph
Operating Temperature Range, T_A	-40°C to +85°C
Storage Temperature Range, T_S	-65°C to +150°C

Capable of monitoring all types of automotive lamps, the ULQ2453M, ULN2454L, ULN2454M, ULN2455A, and ULN2455L lamp monitors provide multiple LED outputs to pinpoint the area in which a lamp has failed. The ULN2455A/L are quad comparators capable of monitoring eight individual lamps or groups of lamps. The ULQ2453M and ULN2454L/M are dual comparators with the latter featuring an additional output to trigger an alarm if either of the comparators detects a lamp failure. This output can be used to drive an audible signaling device or centrally located warning indicator. All devices can be used to monitor lamps, multiple low-voltage power supplies, or, with appropriate sensors, industrial processes.

Installation and operation of these lamp monitors has no effect on normal lamp operation. Comparators sense the normal voltage drop in the lamp wiring (approximately 20 mV) for each of the monitored lamp circuits. Little additional wiring is necessary for installation because the system can be completely integral to the wiring assembly. No standby power is required...the operating voltage is obtained from the sense leads; the system is energized only when the lamps are turned ON.

All devices are designed for use in the severe automotive environment. Lateral PNP transistors provide high-frequency noise immunity and differential transient-voltage protection. Reverse voltage protection, internal regulators, and temperature compensation are all embodied in the circuit designs. A failure within a device will not affect lamp operation.

These versatile lamp monitors are packaged in 14-pin plastic DIPs (suffix A), 8- or 14-lead surface-mountable SOICs (suffix L), or 8-pin mini-DIPs (suffix M) and are rated for operation over the temperature range of -40°C to +85°C.

FEATURES

- No Standby Power
- Integral to Wiring Assembly
- Fail-Safe
- Reverse Voltage Protected
- Internal Transient Protection
- DIP or SOIC Plastic Packages

Always order by complete part number:

Part Number	Function	Style
ULQ2453M	Dual Comparator	8-Pin Mini-DIP
ULN2454L	Dual Comparator with OR Output	8-Lead SOIC
ULN2454M	Dual Comparator with OR Output	8-Pin Mini-DIP
ULN2455A	Quad Comparator	14-Pin DIP
ULN2455L	Quad Comparator	14-Lead SOIC

2453, 2454, 2455 AUTOMOTIVE LAMP MONITORS

PIN OUT & FUNCTIONAL BLOCK DIAGRAMS

ULQ2453M

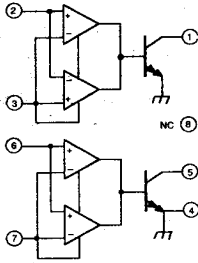

Dwg. FS-009A

**ULN2454L
and ULN2454M**

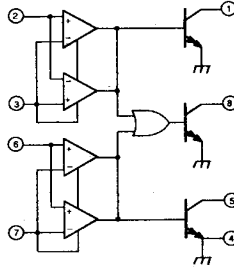

Dwg. FS-010

**ULN2455A
and ULN2455L**

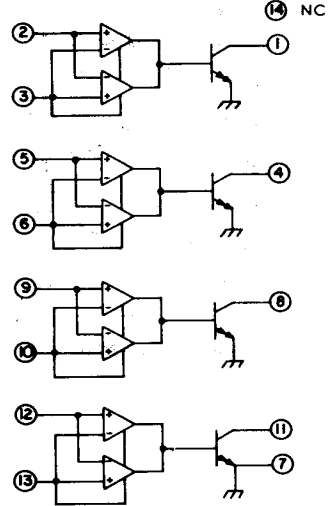

Dwg. No. A-12,033A

Note that the dual in-line package and the small-outline IC package are electrically identical and share a common pin number assignment.

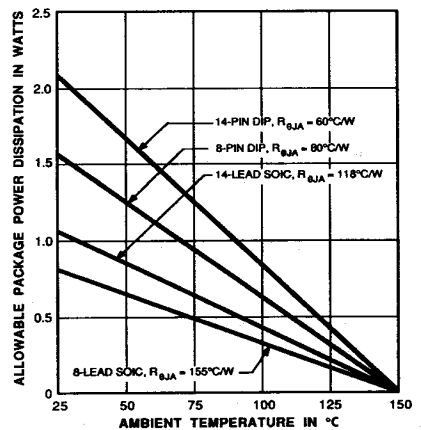

Dwg. GS-008

2453, 2454, 2455

AUTOMOTIVE LAMP MONITORS

**SIMPLIFIED SCHEMATIC
(SINGLE DIFFERENTIAL SENSE AMPLIFIER)**

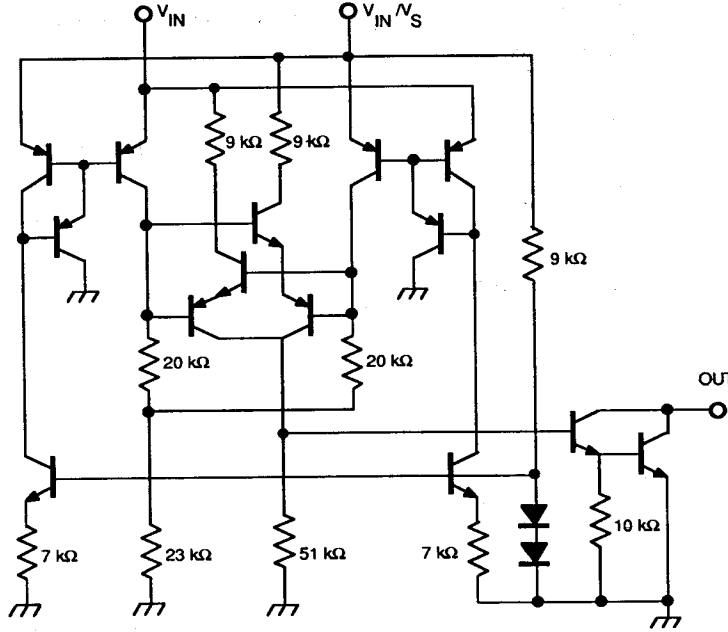

Dwg. ES-011

**ELECTRICAL CHARACTERISTICS at $T_A = +25^\circ\text{C}$, $V_{CC} = V_{IN} = 10$ to 16 V
(unless otherwise noted).**

Characteristic	Symbol	Test Conditions	Limits			Units
			Min.	Typ.	Max.	
Output Leakage Current	I_{CEX}	$V_{OUT} = 80$ V, $\Delta V_{IN} < 7$ mV	—	—	100	μA
Output Saturation Voltage	$V_{CE(SAT)}$	$I_{OUT} = 5$ mA, $\Delta V_{IN} > 20$ mV	—	0.8	1.0	V
		$I_{OUT} = 30$ mA, $\Delta V_{IN} > 20$ mV	—	1.4	2.0	V
Differential Switch Voltage	ΔV_{IN}	$V_{IN} - V_{IN}/V_S$	7.0	13	20	mV
Input Current	I_{IN}	$\Delta V_{IN} = V_{IN} - V_{IN}/V_S = +30$ mV	150	300	800	μA
	I_{IN}/I_S	$\Delta V_{IN} = V_{IN} - V_{IN}/V_S = -30$ mV	0.5	1.7	3.5	mA

2453, 2454, 2455 AUTOMOTIVE LAMP MONITOR

PRINCIPLE OF OPERATION

Operation of these lamp monitors is similar to that of a simple bridge circuit in which the top two legs of the bridge are formed by the wiring assembly resistance or discrete low-value resistors. The bottom legs of the bridge are the monitored lamps. These differential amplifier circuits sense the voltage drops in the wiring assemblies (approximately 20 mV) for each of the lamp circuits. When the system detects a difference in voltage due to an open filament, the appropriate output driver is turned ON.

BASIC BRIDGE MONITORING SYSTEM

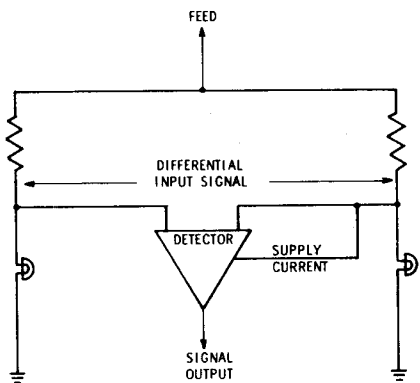

Dwg. No. A-11,473A

TYPICAL SWITCH CHARACTERISTICS

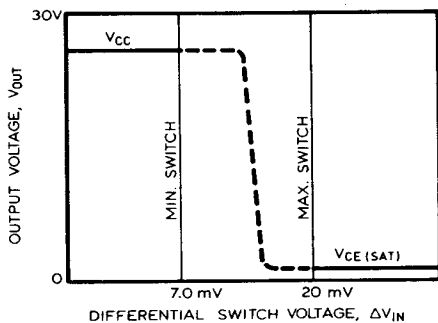

Dwg. No. A-12,187

TYPICAL APPLICATIONS

POWER SUPPLY SUPERVISORY CIRCUIT

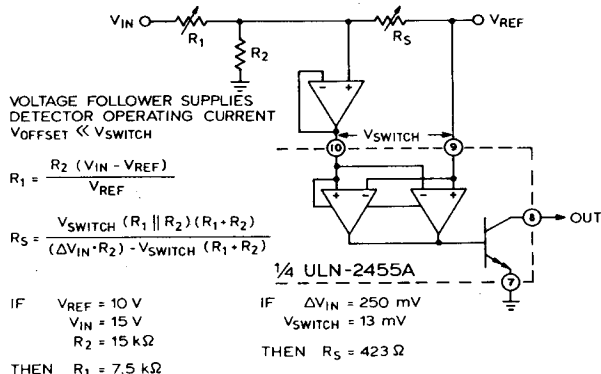

Dwg. No. B-1524

QUAD LAMP MONITOR

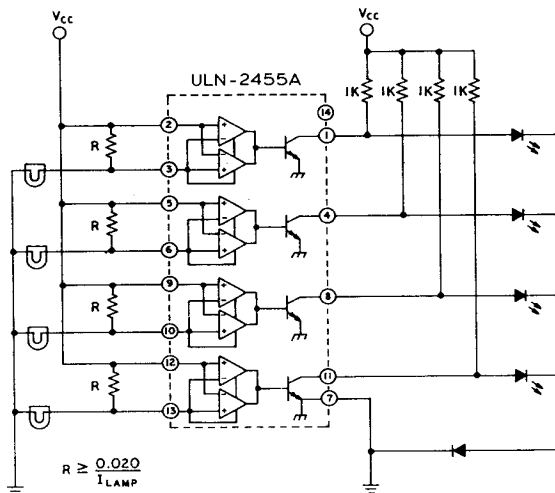

Dwg. No. A-12,035A