

DATA SHEET



TDA9605H

Audio processor with head amplifier
for VHS hi-fi

Product specification
File under Integrated Circuits, IC02

1999 Apr 14

Audio processor with head amplifier for VHS hi-fi**TDA9605H**

CONTENTS			
1	FEATURES	7.8	Volume bytes at subaddresses 04H, 05H and 06H
2	GENERAL DESCRIPTION	7.8.1	Left and right volume control
3	ORDERING INFORMATION	7.9	Power byte at subaddress 07H
4	BLOCK DIAGRAM	7.9.1	Calibration start
5	PINNING	7.9.2	DC output voltage selection
6	FUNCTIONAL DESCRIPTION	7.9.3	Test mode
6.1	Record-mute mode or head identification selection	7.9.4	Power-on reset
6.2	Hi-fi audio output level	7.9.5	Head amplifier disable
6.3	Reference current	7.9.6	Power muting
6.4	Head amplifier	7.9.7	Standby select
6.4.1	Playback mode	7.10	Read byte
6.4.2	Record-mute mode	7.10.1	Calibration ready
6.4.3	Record mode	7.10.2	Auto-normal selection
6.4.4	Head amplifier power supply and ground	7.10.3	Calibration error
6.5	Automatic calibration	7.10.4	Power-on reset
6.6	Power muting	8	LIMITING VALUES
6.7	Envelope output	9	THERMAL CHARACTERISTICS
6.8	RF converter output	10	GENERAL CHARACTERISTICS
6.9	Audio dubbing	11	RECORD-MUTE MODE CHARACTERISTICS
6.9.1	Output mix	12	RECORD MODE CHARACTERISTICS
6.9.2	Input mix	13	PLAYBACK MODE CHARACTERISTICS
7	I ² C-BUS PROTOCOL	14	APPLICATION AND TEST INFORMATION
7.1	Addresses and data bytes	14.1	RM and HID control signals
7.2	Valid transmissions to and from the TDA9605H	14.2	Reference current resistor
7.3	Overview of the TDA9605H I ² C-bus control	14.3	Setting line output level
7.4	Control byte at subaddress 00H	14.4	Test modes
7.4.1	Audio FM mode	15	INTERNAL CIRCUITRY
7.4.2	Playback mode	16	PACKAGE OUTLINE
7.4.3	Record mode	17	SOLDERING
7.4.4	System standard selection	17.1	Introduction to soldering surface mount packages
7.4.5	Head amplifier playback amplification	17.2	Reflow soldering
7.4.6	Head amplifier record current	17.3	Wave soldering
7.5	Select byte at subaddress 01H	17.4	Manual soldering
7.5.1	Decoder output select	17.5	Suitability of surface mount IC packages for wave and reflow soldering methods
7.5.2	Head amplifier record current range select	18	DEFINITIONS
7.5.3	Normal input level	19	LIFE SUPPORT APPLICATIONS
7.6	Input byte at subaddress 02H	20	PURCHASE OF PHILIPS I ² C COMPONENTS
7.6.1	Input select		
7.6.2	Normal select		
7.7	Output byte at subaddress 03H		
7.7.1	Line output amplification		
7.7.2	Output select		
7.7.3	Envelope output select		
7.7.4	Line output select		
7.7.5	Decoder output select		
7.7.6	RF converter mute		

Audio processor with head amplifier for VHS hi-fi

TDA9605H

1 FEATURES

- All functions controlled via the serial 2-wire I²C-bus
- Integrated standby modes for low power consumption
- Audio FM head amplifier:
 - Programmable recording current
 - Programmable playback amplification
 - Fast record-mute mode control input.
- Hi-fi signal processing:
 - Adjustment free
 - High performance
 - Low distortion switching noise suppressor
 - NTSC and PAL (SECAM) system.
- Linear audio input:
 - Programmable (playback) level.
- 5 stereo inputs and additional mono Second Audio Program (SAP) input
- 2 stereo outputs (line and decoder) with independent output select function
- RF converter output with overload-protection AGC
- Integrated output power muting
- Audio level meter output
- Extensive input and output select function
- Full support of video recorder feature modes.

**2 GENERAL DESCRIPTION**

The TDA9605H is a single-chip device in a small package that contains all the required functions, including the head amplifier, to realize the audio FM hi-fi stereo system in a VHS video recorder (see Fig.1). The device is adjustment free by use of an integrated auto-calibration system. Extensive signal select functions are offered to support pay-TV decoding and video recorder feature modes.

The high performance and functionality of the TDA9605H comprises world-wide system and application requirements for NTSC, PAL, SECAM and multi-standard video recorders from basic up to high-end models.

3 ORDERING INFORMATION

TYPE NUMBER	PACKAGE		
	NAME	DESCRIPTION	VERSION
TDA9605H	QFP44	plastic quad flat package; 44 leads (lead length 1.3 mm); body 10 × 10 × 1.75 mm	SOT307-2

Audio processor with head amplifier for VHS hi-fi

TDA9605H

4 BLOCK DIAGRAM

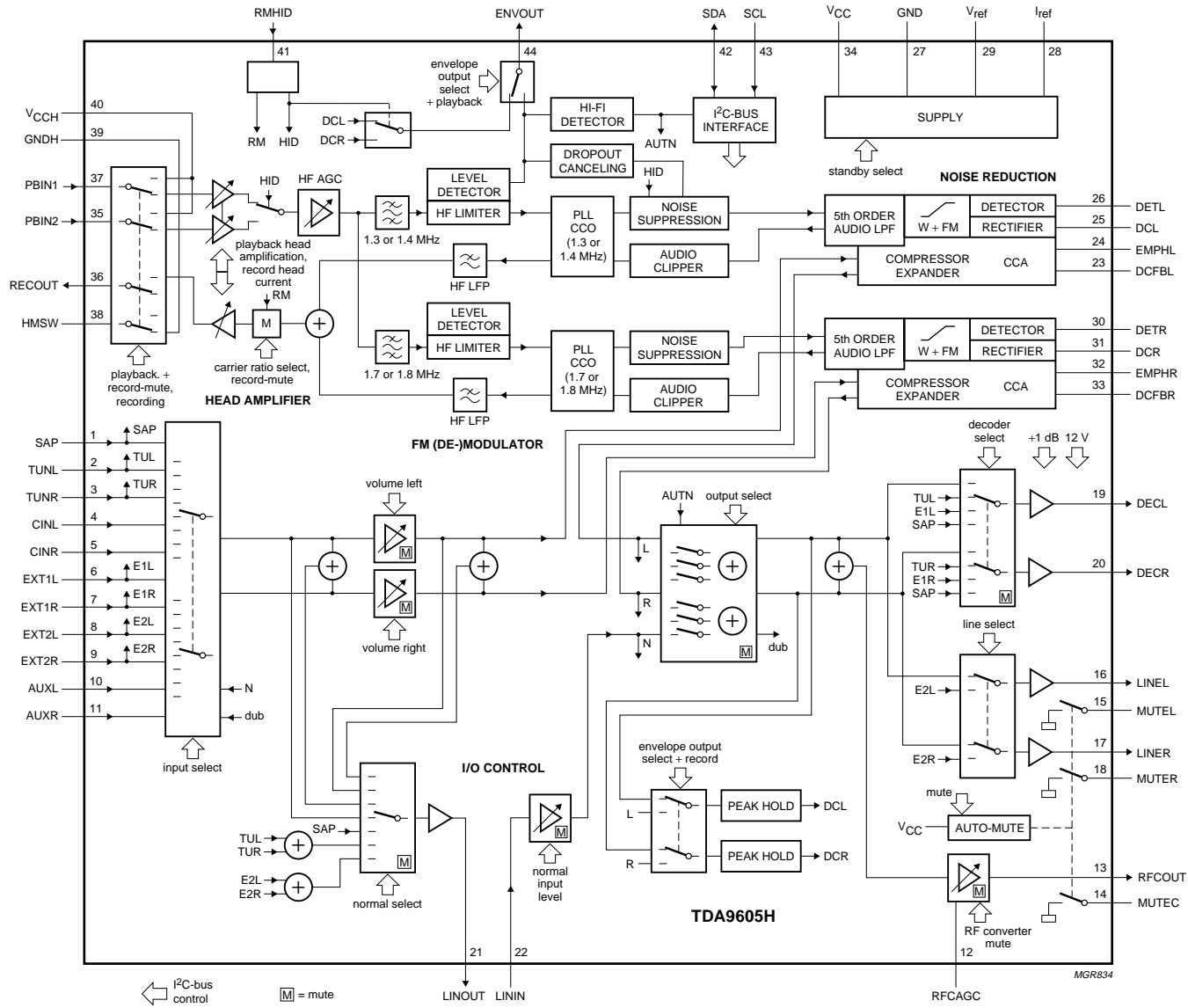

Fig.1 Block diagram.

Audio processor with head amplifier for VHS hi-fi

TDA9605H

5 PINNING

SYMBOL	PIN	DESCRIPTION
SAP	1	tuner input mono
TUNL	2	tuner input left
TUNR	3	tuner input right
CINL	4	CINCH input left
CINR	5	CINCH input right
EXT1L	6	external 1 input left
EXT1R	7	external 1 input right
EXT2L	8	external 2 input left
EXT2R	9	external 2 input right
AUXL	10	auxiliary input left
AUXR	11	auxiliary input right
RFCAGC	12	RF converter AGC timing connection
RFCOUT	13	RF converter output
MUTEC	14	mute for RF converter output
MUTEL	15	mute for line output left
LINEL	16	line output left
LINER	17	line output right
MUTER	18	mute for line output right
DECL	19	decoder output left
DECR	20	decoder output right
LINOUT	21	linear audio output
LININ	22	linear audio input
DCFBL	23	DC feedback noise reduction connection left
EMPHL	24	emphasis noise reduction connection left

SYMBOL	PIN	DESCRIPTION
DCL	25	DC decoupling noise reduction connection left
DETL	26	detector noise reduction connection left
GND	27	ground
I _{ref}	28	reference standard current connection
V _{ref}	29	reference voltage connection
DETR	30	detector noise reduction connection right
DCR	31	DC decoupling noise reduction connection right
EMPHR	32	emphasis noise reduction connection right
DCFBR	33	DC feedback noise reduction connection right
V _{CC}	34	power supply
PBIN2	35	head 2 playback input
RECOUT	36	recording current output
PBIN1	37	head 1 playback input
HMSW	38	head amplifier mode switch connection
GNDH	39	ground of head amplifier
V _{CCH}	40	power supply of head amplifier
RMHID	41	record-mute mode or head identification input
SDA	42	I ² C-bus data input/output
SCL	43	I ² C-bus clock input
ENVOUT	44	HF or AF envelope output

Audio processor with head amplifier for VHS hi-fi

TDA9605H

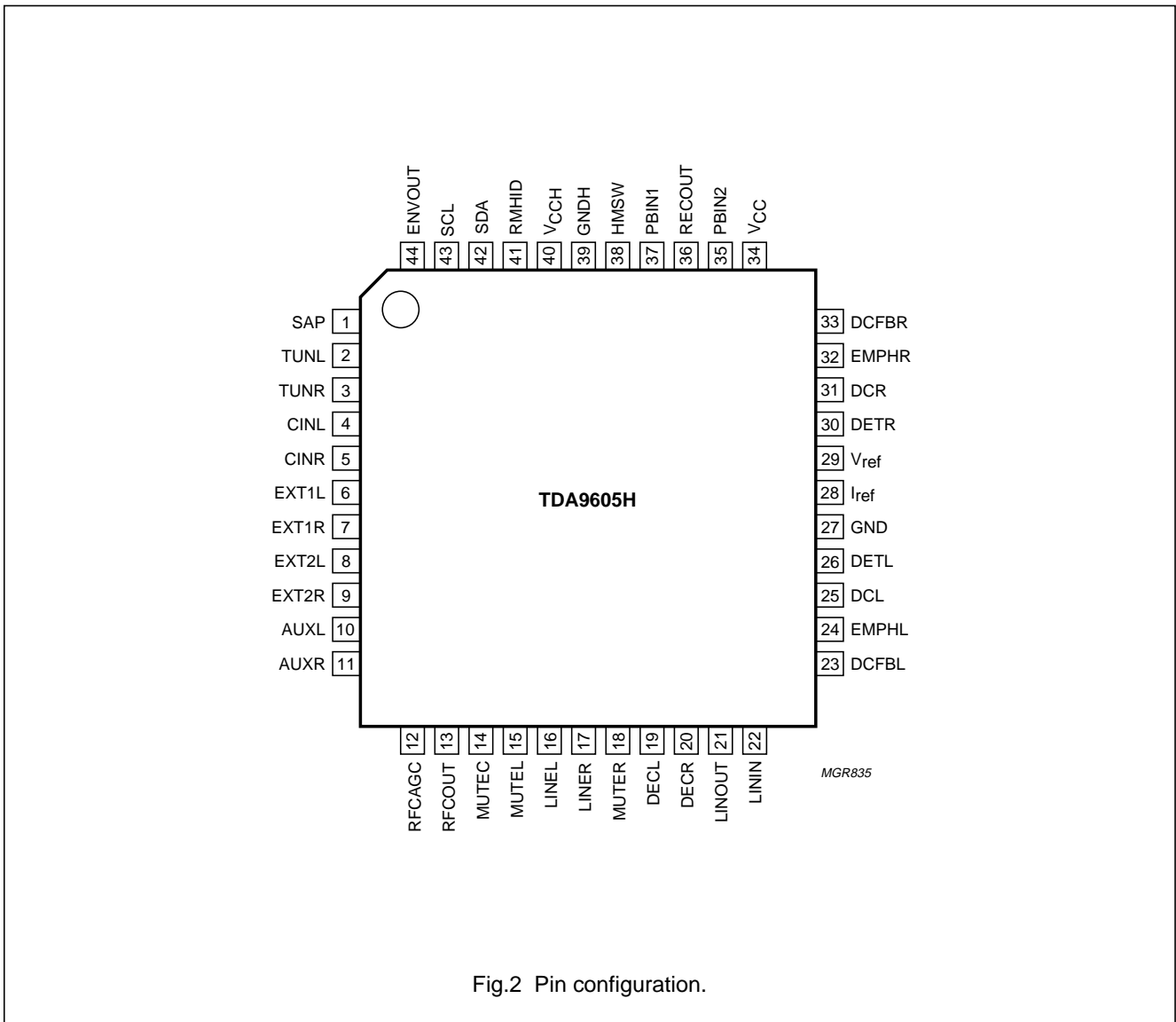

Fig.2 Pin configuration.

6 FUNCTIONAL DESCRIPTION

Input and output selections for the various modes are given in the following diagrams:

- Standard operating mode (see Fig.3)
- Dub-mix mode (see Fig.4)
- Standby mode: active or passive (see Fig.5).

Audio processor with head amplifier for VHS hi-fi

TDA9605H

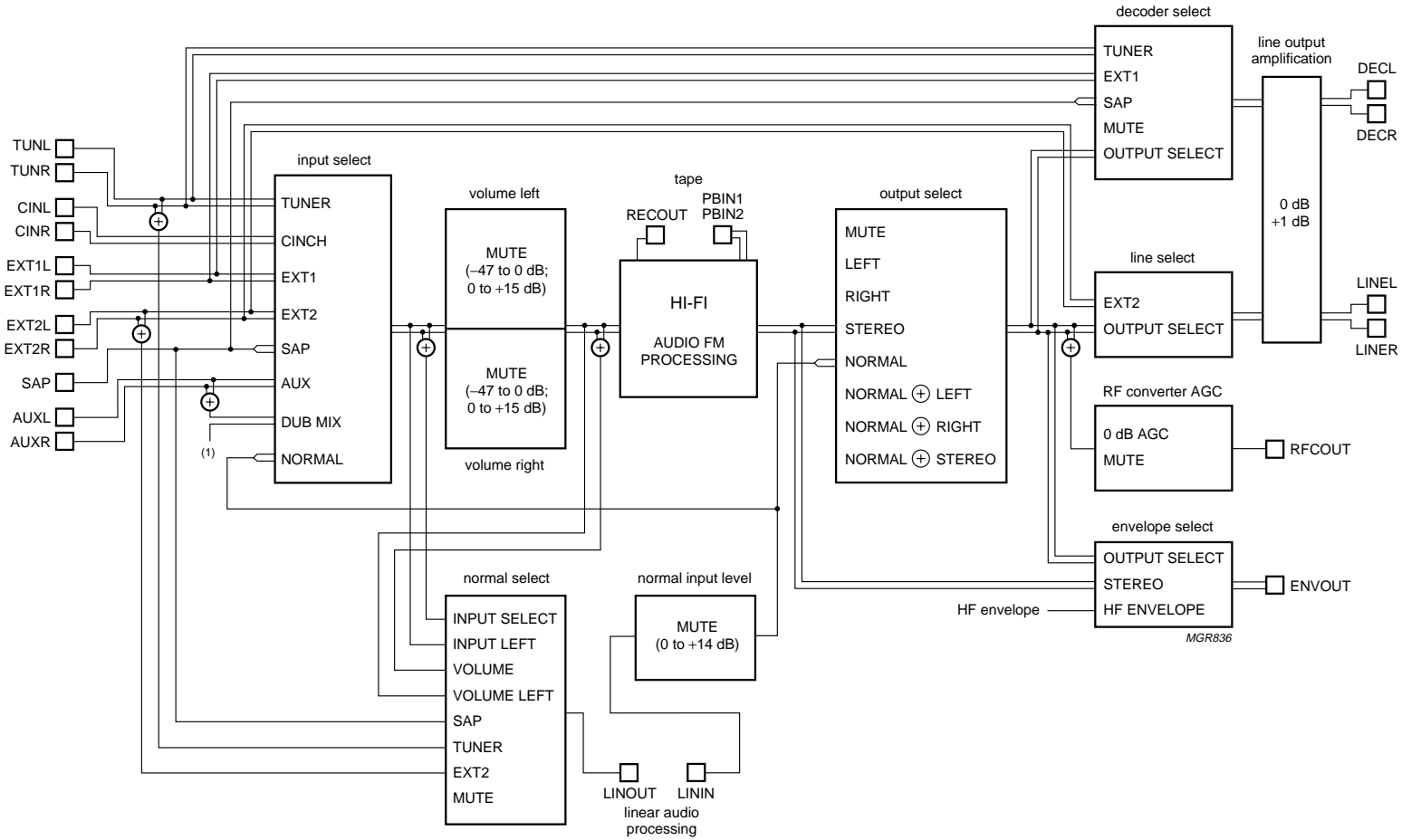

(1) For dub-mix mode signal selections see Fig.4.

Fig.3 Input and output selections for standard operating mode.

Audio processor with head amplifier for VHS hi-fi

TDA9605H

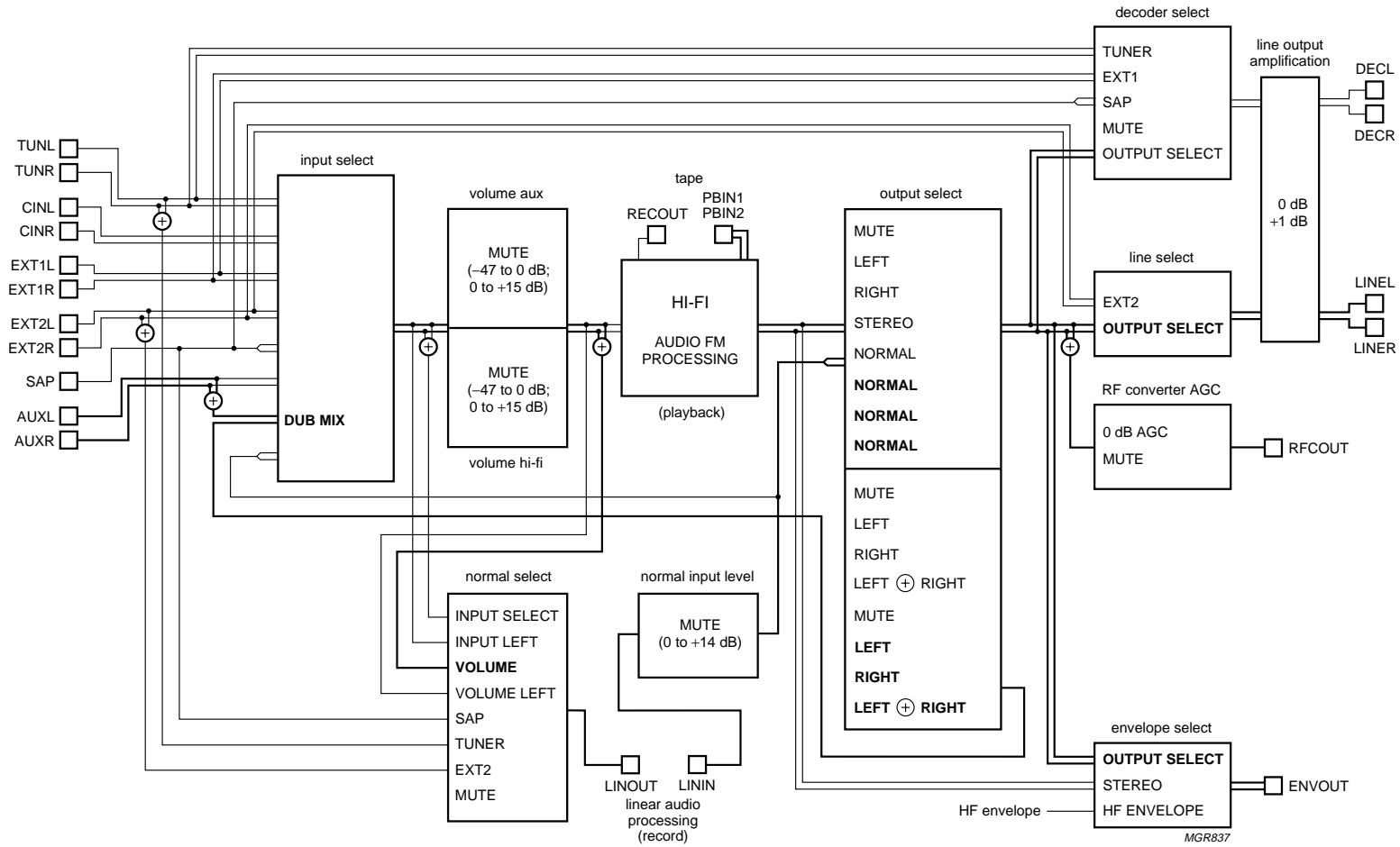

Dub-mix mode: IS2 = 1, IS1 = 0 and IS0 = 1.

Input mixing of the hi-fi (playback) signal with the auxiliary, used for linear audio dubbing recording.

Selections generally used in combination with dub-mix mode are shown in heavy line type.

Fig.4 Input and output selections for dub-mix mode.

Audio processor with head amplifier for VHS hi-fi

TDA9605H

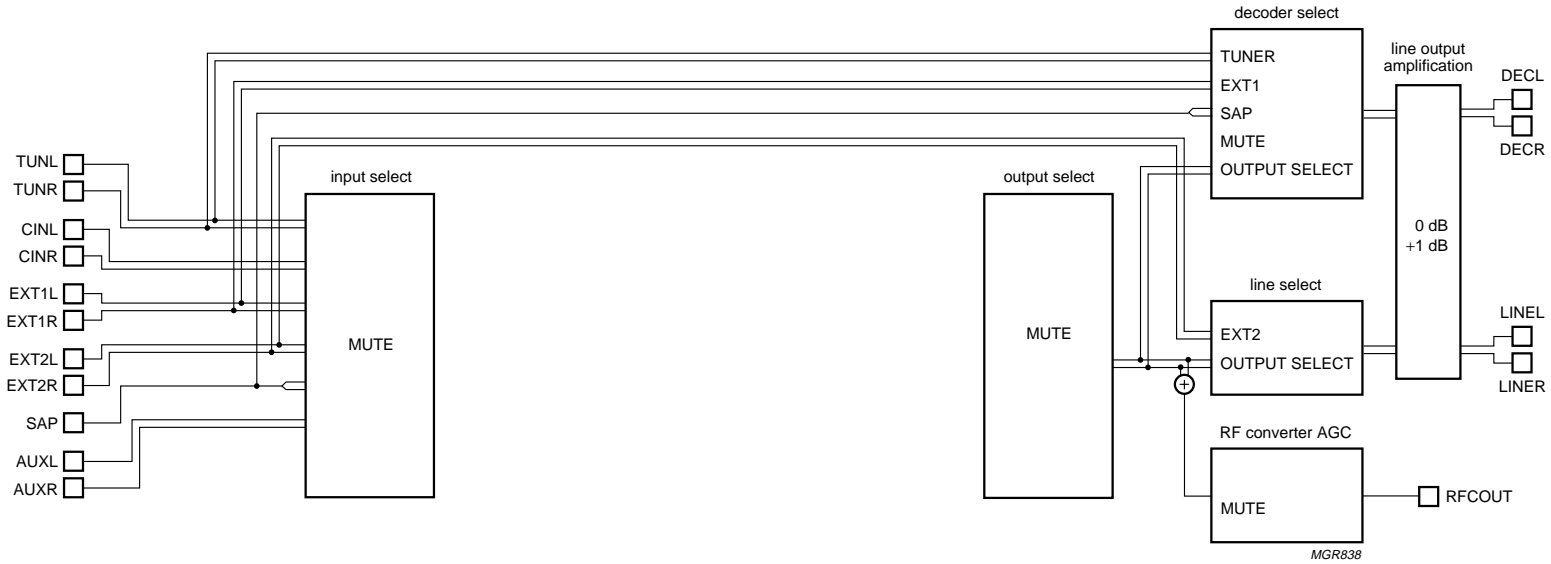

a. Active standby mode (bit STBA = 1, bit STBP = 0); over 80% power reduction.

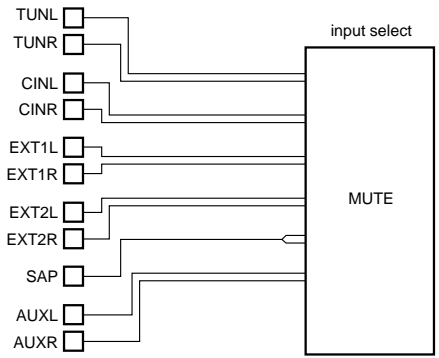

b. Passive standby mode (bit STBP = 1); over 90% power reduction.

Fig.5 Input and output selections for standby modes.

Audio processor with head amplifier for VHS hi-fi

TDA9605H

6.1 Record-mute mode or head identification selection

Pin RMHID allows input of two independent digital control signals for selecting the record-mute or head identification modes which are voltage coded. The RM control signal is selected via a 10 k Ω resistor and the HID control signal is selected via a 18 k Ω resistor. This set-up enables the two signals within the TDA9605H to be separated. The RM control signal is only in use during the record mode (bit AFM = 1); during the playback mode (bit AFM = 0) the RM signal is ignored. Pin RMHID should be connected to ground when the RM control signal is not used.

The use of the RM control signal is optional since the same function is available via the I²C-bus control in the record-mute mode. However, accurate timing of recording start and stop may sometimes be difficult to realize via the I²C-bus control. In this event the RM control signal can be used instead. There is also the possibility to use the record-mute mode control line of the video head amplifier.

6.2 Hi-fi audio output level

When the application circuit is used in accordance with the application diagram, the standard FM deviation of 50 kHz equals a 1 kHz audio signal of -8 dBV line output level (bit LOH = 0). A different standard audio level can be selected by changing the external filter components of the noise reduction on pins EMPHL and EMPHR (see Section 14.3). The standard audio level changes proportionally to the impedance of the external de-emphasis filter.

6.3 Reference current

The external resistor connected to pin I_{ref} defines the internal reference currents and determines the temperature stability of circuits adjusted by the auto-calibration function.

6.4 Head amplifier

6.4.1 PLAYBACK MODE

The playback mode is selected by setting bit AFM = 0. During the playback mode the input circuit on pins PBIN2 and PBIN1 is enabled (see Fig.6). Pin RECOUT is disabled and pin HMSW shows a low impedance to ground, so realizing an AC ground for the head circuit via the external capacitor connected between these pins.

The head identification (HID) signal on pin RMHID selects between the head signals on pins PBIN2 or PBIN1. Head selection is defined as shown in Table 1.

The state of the RM control signal on pin RMHID is don't care in the playback mode.

I²C-bus control bits HAC2, HAC1 and HAC0 offer a wide selection of playback amplification to fit different head and head transformer specifications. The advised setting of the playback amplification realizes a level of 24 mV (RMS) for each carrier signal after the head amplifier to obtain a 17 dB overhead compared to the auto-normal level (hi-fi detection). However, performance is not critical and a different setting can be used if desired.

The carrier level can be measured using the HF envelope output voltage on pin ENVOUT (bit EOS = 1). During standard operating mode the HF envelope signal is derived from the left channel carrier amplitude (1.3 or 1.4 MHz carrier) but the special test 10 of the test mode also enables the HF envelope output of the right channel carrier amplitude (1.7 or 1.8 MHz carrier). The advised carrier playback level of 24 mV (RMS) equals an HF envelope voltage of 3.3 V.

The head amplifier output signal can be monitored directly by using test 8 of the test mode. Pin ENVOUT functions as the test output showing 6 dB attenuation compared to the actual head amplifier output level (see Section 14.4).

Table 1 Selection of the head signal

HID SIGNAL	LEVEL ON PIN RMHID	SELECTION OF HEAD SIGNAL
LOW	lower than 0.6 V or between 2.65 and 3.8 V	pin PBIN2 (head 2)
HIGH	between 1.0 and 2.35 V or higher than 4.3 V	pin PBIN1 (head 1)

6.4.2 RECORD-MUTE MODE

The record-mute mode is selected by setting bit AFM = 1 and either setting bits DOC, SHH and DETH to logic 0 or switching the RM control signal to HIGH-level.

During the record-mute mode no recording current is present on pin RECOUT (see Fig.6). The head amplifier status actually equals the playback mode, however, the second amplifier stage is disabled to minimize power consumption.

The RM control signal on pin RMHID enables fast switching between the record and record-mute modes (see Table 2). If the I²C-bus control is set to the record mode, the use of record-mute mode control via pin RM allows for accurate timing of recording start and stop, independent of the I²C-bus control (see Section 6.1).

Audio processor with head amplifier for VHS hi-fi

TDA9605H

Table 2 Selection of recording modes

RM SIGNAL	LEVEL ON PIN RMHID	RECORD MODE
LOW	lower than 2.35 V	record or record-mute mode as defined by I ² C-bus control
HIGH	higher than 2.65 V	record-mute mode

6.4.3 RECORD MODE

The record mode is selected by setting bit AFM = 1 and setting bits DOC, SHH and DETH from logic 001 to 111 and switching the RM control signal to LOW-level.

During the record mode actual recording is activated and the recording current is output on pin RECOU_T (see Fig.6). Pins PBIN₂ and PBIN₁ form a connection to the 5 V head amplifier supply voltage (V_{CCH}). Pin HMSW is internally connected to pin RECOU_T and the external capacitor has no function in this mode.

The desired carrier mix ratio is set via I²C-bus control bits DOC, SHH and DETH. A wide selection of recording currents is available to fit different head and head transformer specifications and are set via bits HAC₂, HAC₁, HAC₀ and range bit HRL. The setting of the carrier mix ratio does not change the selected recording current.

The DC bias current on pin RECOU_T is changed proportional to the selected recording current for optimizing the performance and minimizing the power consumption for each recording current selected.

A Boucherot damping circuit is connected between pin HMSW and ground to prevent head current resonance peaking. A capacitor of 10 nF and a resistor of 470 Ω are specified in Fig.14, but the component values are not critical.

6.4.4 HEAD AMPLIFIER POWER SUPPLY AND GROUND

The head amplifier is supplied via a separate 5 V supply (pin V_{CCH}) and ground (pin GNDH).

A capacitor of 100 nF should be placed close to the device between pins V_{CCH} and GNDH for proper decoupling of the power supply.

The head amplifier ground (pin GNDH) should be connected to the main ground (pin GND).

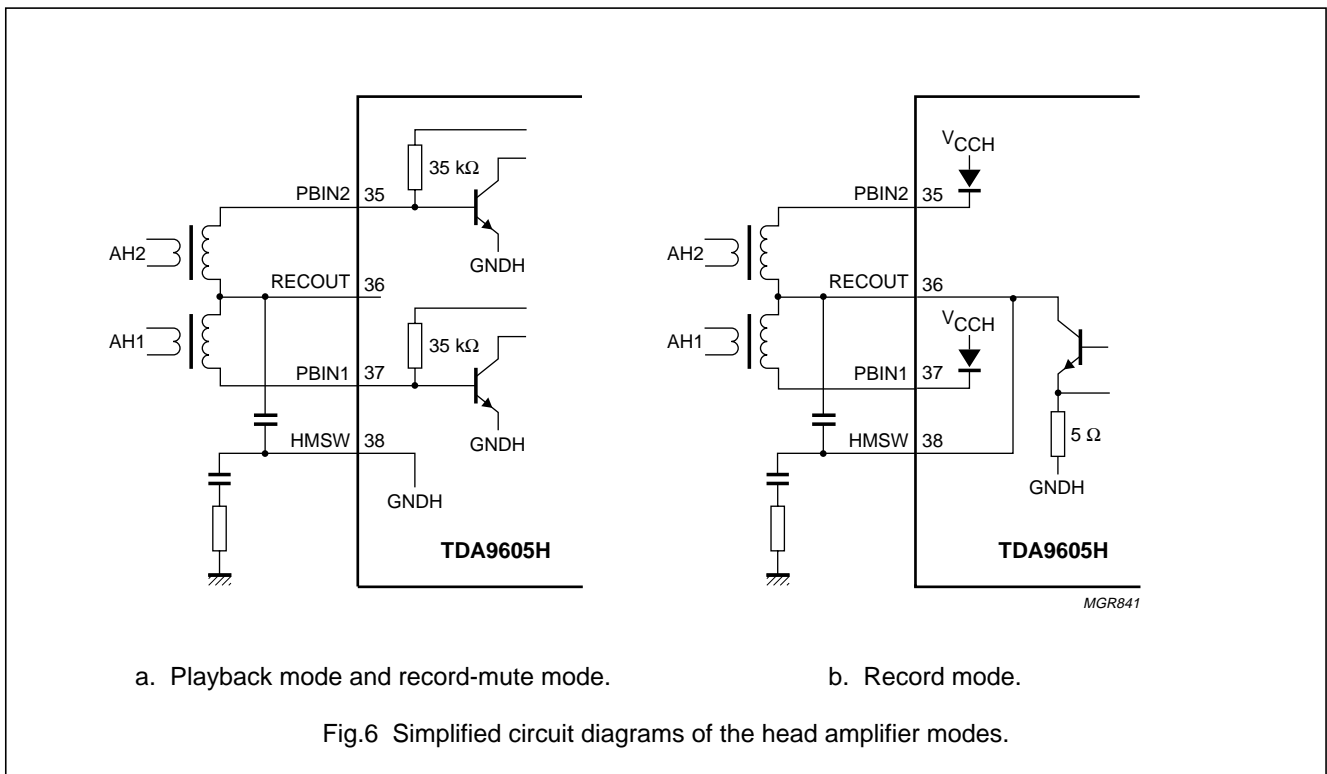

Audio processor with head amplifier for VHS hi-fi

TDA9605H

6.5 Automatic calibration

The integrated auto-calibration system is activated by means of bit CALS of the power byte (see Fig.7). The auto-calibration system ensures hi-fi processing is well in accordance with the VHS hi-fi system standard by an automated adjustment of carrier frequencies, band-pass filters and noise reduction filters. Calibration is only needed after start-up of the video recorder. The calibration settings remain stable as long as the supply voltage (V_{CC}) is present.

Auto-calibration is only executed in the record-mute mode or record mode and no standby mode or test mode should be selected, i.e. auto-calibration requires the setting of bit AFM = 1, bit STBP = 0, bit STBA = 0 and bit TEST = 0. Auto-calibration is started after setting bit CALS = 1. Calibration is performed fully automatically, using the HID control signal as a time reference. Audio signals are not disturbed during the calibration process.

Calibration of the oscillator frequencies is performed by measuring the number of oscillator cycles within one period when the HID control signal is at HIGH-level and comparing this result with an internal value stored in the Read Only Memory (ROM). Four different ROM values are available for NTSC or PAL (SECAM) system calibration of both the left and right channel carrier.

In case of NTSC a special routine is active for the calibration of the right channel carrier which results in a

frequency difference between the left and right channel carrier near to 401.2 kHz. This value effectively reduces the crosstalk from hi-fi carriers to video colour signal as present during Extended Play (EP) tape speed. NTSC calibration uses a standard HID control signal of 29.97 Hz (pulse width = 16.683 ms) where PAL calibration uses a standard HID control signal of 25 Hz (pulse width = 20 ms). After auto-calibration the maximum frequency error is ± 5 kHz assuming a time error of maximum of 5 μ s when the HID control signal is at HIGH-level. Jitter on the HID control signal should not exceed 1 μ s to realize EP optimization within ± 2 kHz for NTSC. In general, the crystal based HID control signal available in the video recorder can be used without modification.

When the calibration of the oscillators is completed the band-pass filters are calibrated. The integrated weighting and FM de-emphasis filters of the noise reduction are calibrated at the same time.

The total auto-calibration time needed is maximum 17 cycles of the HID control signal. Completion of the calibration is signalled by bit CALR = 1 of the read byte.

The calibration can also be monitored by means of the envelope output. For this purpose the voltage on pin ENVOUT is forced to >2.5 V during the calibration. The audio signal to the audio envelope function (level meter) should be muted (i.e. output select = mute).

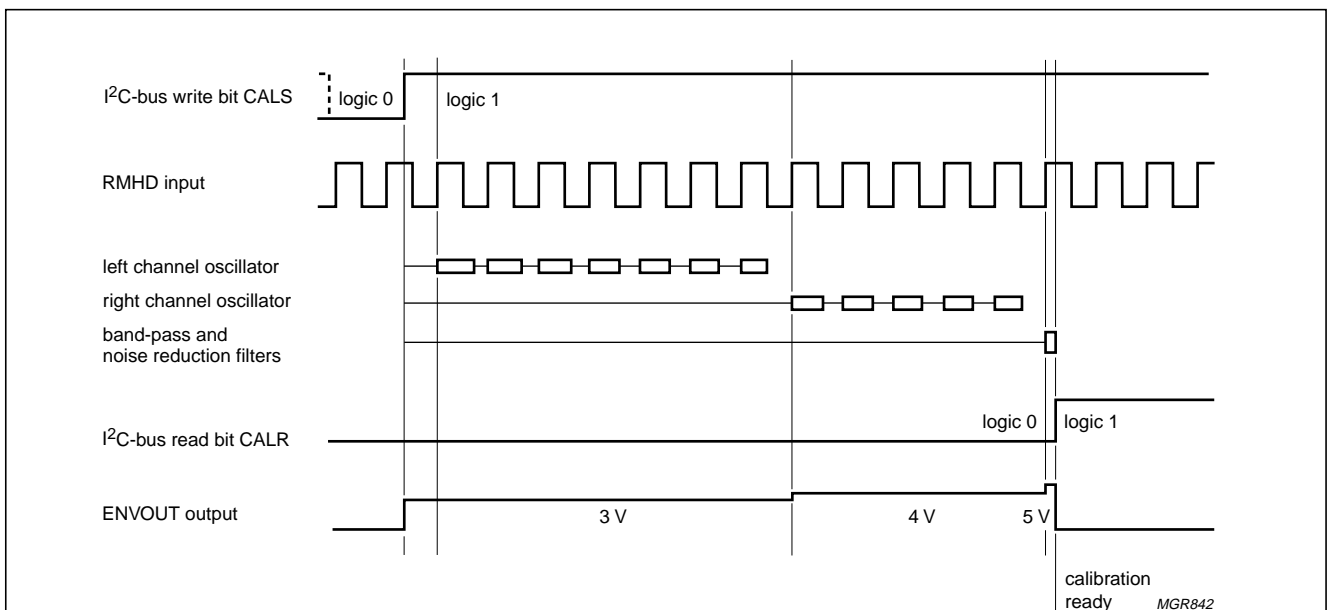

Fig.7 Example of automatic calibration flow.

Audio processor with head amplifier for VHS hi-fi

TDA9605H

Otherwise, the audio envelope output voltage may become >2.5 V which makes it impossible to detect the completion of the calibration on pin ENVOUT.

Calibration relies upon the frequency accuracy of the HID control signal. The calibration result may be incorrect when the HID control signal is disturbed during a critical part of the calibration. An additional check is incorporated to detect such a situation by reading bit CALE during calibration. When bit CALE = 1, the calibration result is detected to be unreliable due to external causes. A new auto-calibration can be started by setting bit CALS = 0 followed by setting bit CALS = 1. Bit CALE always reads logic 1 when bit CALS is logic 0.

The oscillators and band-pass filters can be switched between NTSC and PAL system frequencies after a calibration in NTSC or PAL mode without the need of additional calibration. Switching between these system modes is executed immediately and can be done in any operating mode. The frequency accuracy of system switching is 100 ±3 kHz for both carriers. To obtain the best possible frequency accuracy in the record mode it is good practice to recalibrate after system switching.

6.6 Power muting

Switching off and on of the power supply voltage or using the built-in passive standby mode results in rising and dropping of the output DC voltages and causes strong disturbances on the output pins. The TDA9605H includes three integrated mute switches to block such disturbances so avoiding the need for an external mute circuit. Pop-free line and RF converter output signals are realized by connecting the integrated power mute switches behind the line and RFC output capacitors.

Power muting is active when bit MUTE = 1 (see Fig.8). Power muting is automatically activated when V_{CC} is switched on, because this situation is the Power-on reset default state. The integrated mute switches on pins MUTE_{EC}, MUTE_L and MUTE_R are closed and form a low-impedance path to ground. Furthermore, the pins RFCOUT, LINEL and LINER are current limited to -1 mA to avoid excessive supply currents and to achieve good noise attenuation without the need for a series resistor between the output and mute pins. Pins DECL and DECR are also current limited for using the integrated power mute switches or for assisting external muting.

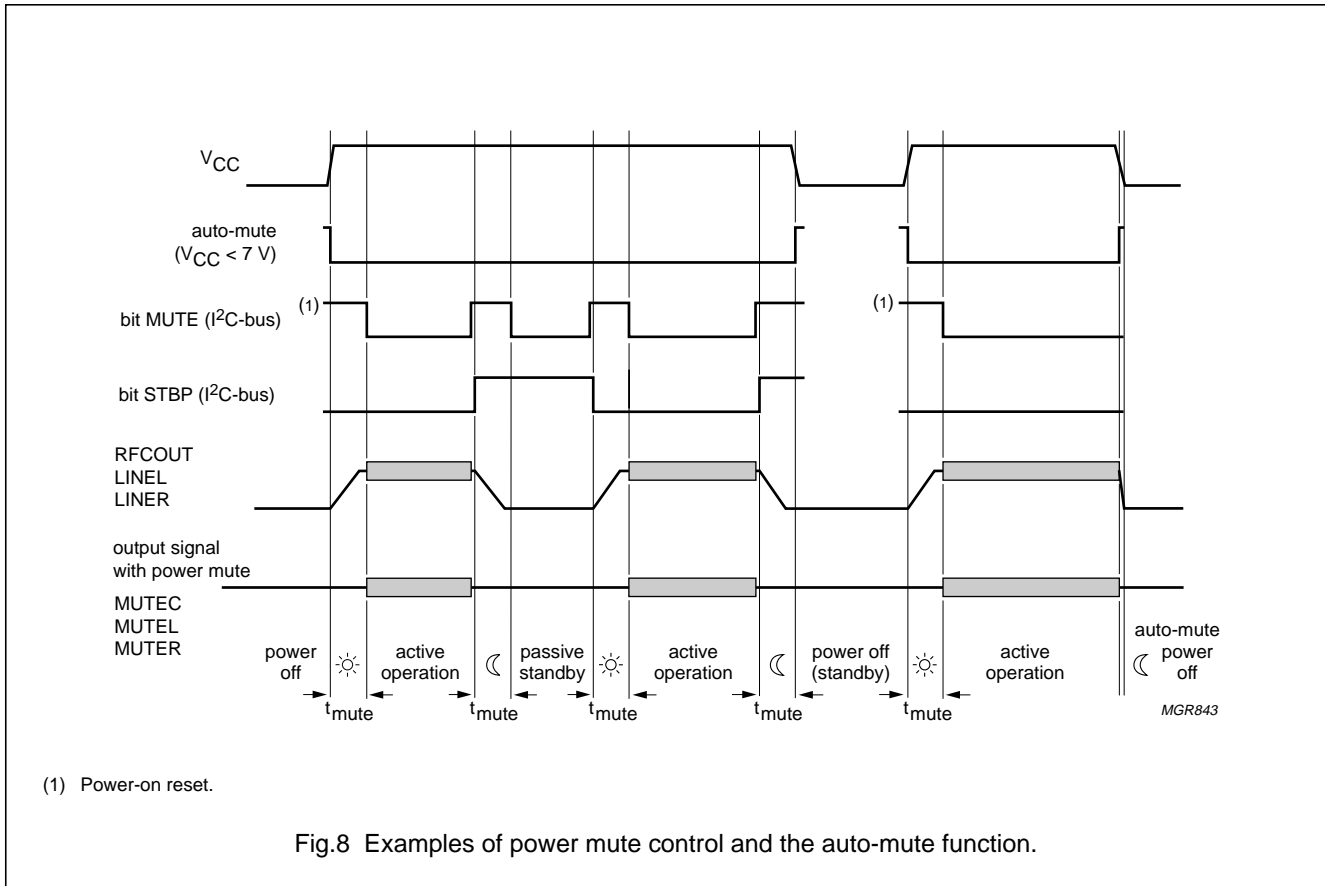

Fig.8 Examples of power mute control and the auto-mute function.

Audio processor with head amplifier for VHS hi-fi

TDA9605H

During power muting the internal output signal is also muted. After the output DC voltage has been established power muting can be de-activated by setting bit MUTE = 0. Now the mute switches are opened resulting in a high-impedance path of 100 k Ω to ground. The output current limiting is not active.

Power muting is also used in combination with the integrated passive standby mode (bit STBP = 1). During this mode the output circuits are switched off and the line, decoder and RF converter output voltages decrease to 0 V using a discharge current of 1 mA. Do not set power mute mode and change the passive standby mode at the same time. Power mute mode should be activated first, followed by switching on or off of the passive standby mode to avoid possible output glitches.

It should be noted that the time needed for stabilizing the output DC voltage is proportional to the output capacitor value. A safe mute time is 200 ms using a 10 μ F capacitor ($t_{\text{mute}} = C \times 20000$ s). Power muting consumes approximately 4 mA additional supply current, so to obtain minimum power consumption the mute mode should be de-activated after use. Very good performance is achieved for power-up, power-down and passive standby mode switching.

An auto-mute function is included which activates power muting when the supply voltage drops below 7 V. The performance of this auto-mute function depends upon the power voltage drop rate. The voltage drop rate should not exceed 1 V during 10 ms. The best performance independent of voltage drop rate is realized by activating the passive standby mode before switching off the power supply voltage (by setting bit MUTE = 1 and bit STBP = 1).

6.7 Envelope output

Pin ENVOUT is an analog output for stereo audio level (e.g. level meter display) and for playback FM carrier level (e.g. auto-tracking). The functional diagram is given in Fig.9 and the timing diagram is shown in Fig.10. Only one ADC input is needed on the microcontroller for reading all the required information.

During the playback mode the selection between audio level and carrier level information is realized by setting I²C-bus control bit EOS (see Table 3). The AF envelope output is defined by the signal selection made at the output select.

During the record mode bit EOS offers the selection between the audio level of the output select or the audio level of the fixed hi-fi stereo signal. This is a helpful setting when the microcontroller uses the audio level information to adjust the hi-fi recording level (volume control).

The HF envelope output signal is continuous and is derived from the left channel carrier. The HF envelope output exhibits a logarithmic characteristic (see Fig.11).

In a standard application circuit only the left channel carrier level is required to support auto-tracking or manual tracking. However, test 10 of the special test mode allows for the right channel carrier level output instead for measurement purposes (see Section 14.4).

The AF envelope output as a function of the output level is given in Fig.12.

The AF envelope circuit uses time multiplexing for the left and right channel audio level. A peak-hold function and dynamic range compression (square root function) are included for easy read out. The peak-hold function and the left and right channel multiplexing are controlled by the HID control signal on pin RMHID (see Table 4).

Table 3 Selection of the envelope output

MODE	BIT AFM	BIT EOS	ENVELOPE OUTPUT	FUNCTION
Playback	0	0	AF envelope: via output select	level meter display
		1	HF envelope	auto-tracking or manual tracking display
Record	1	0	AF envelope: via output select	level meter display
		1	AF envelope: hi-fi stereo	record volume control (and level display)

Table 4 AF envelope output with channel multiplexing

HID SIGNAL	LEVEL ON PIN RMHID	AF ENVELOPE OUTPUT
LOW	lower than 0.6 V or between 2.65 and 3.8 V	left channel audio peak level
HIGH	between 1.0 and 2.35 V or higher than 4.3 V	right channel audio peak level

Audio processor with head amplifier for VHS hi-fi

TDA9605H

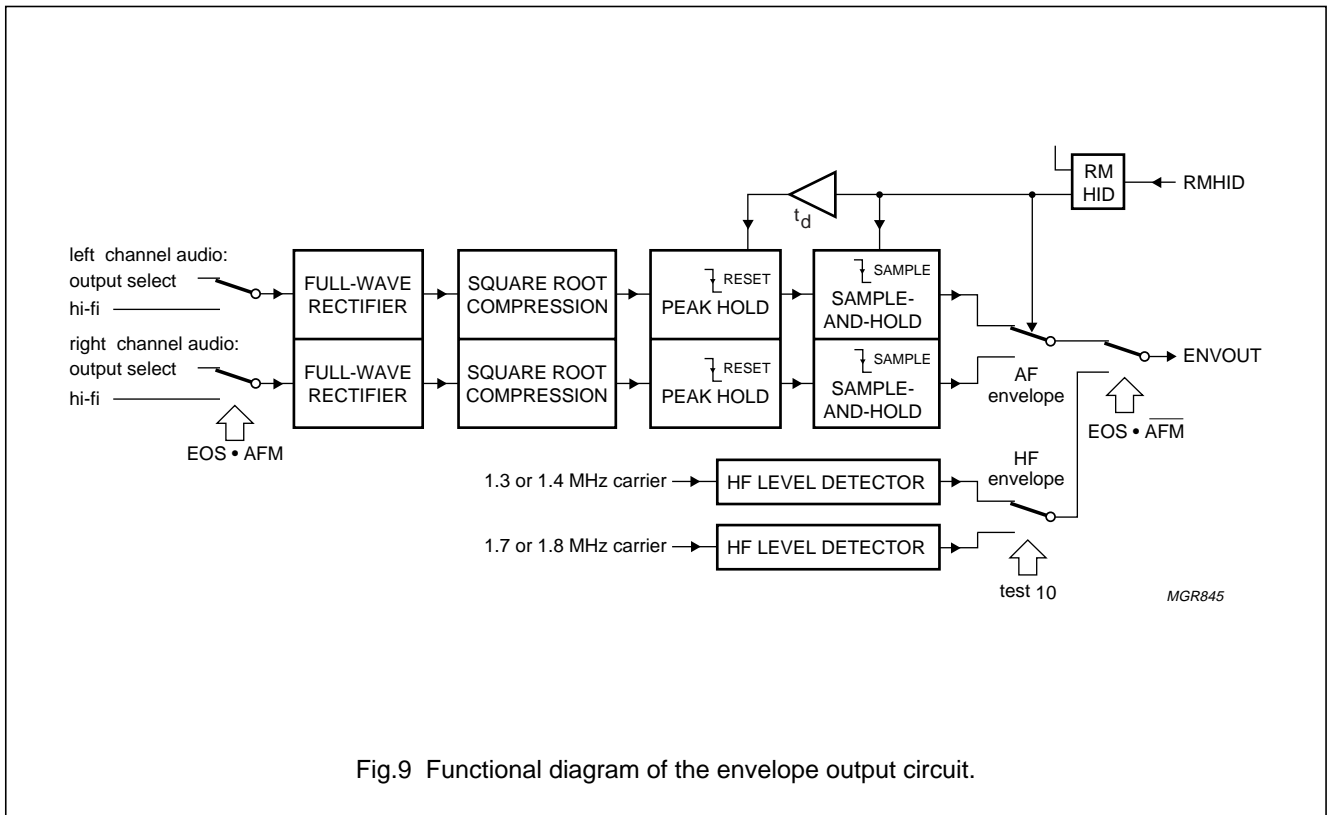

Fig.9 Functional diagram of the envelope output circuit.

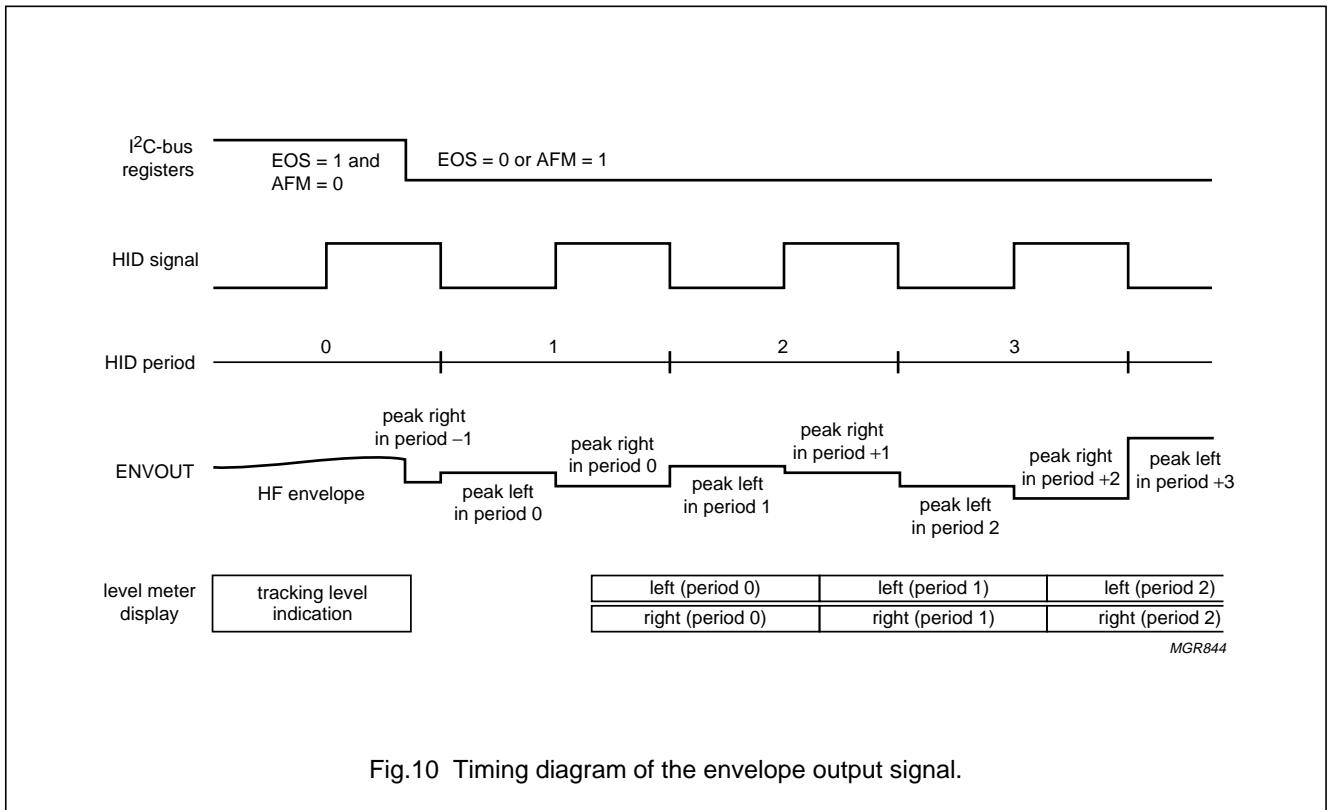
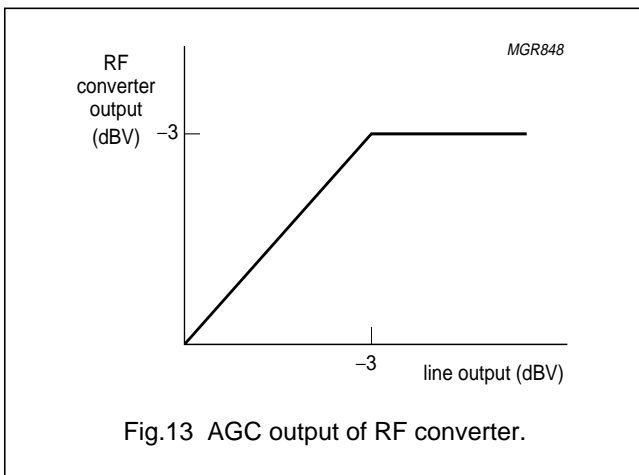
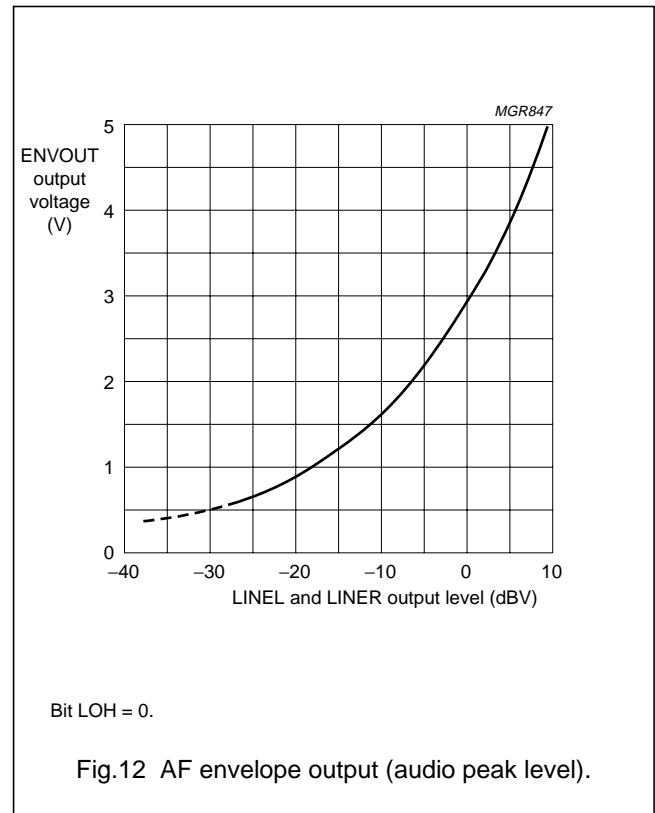
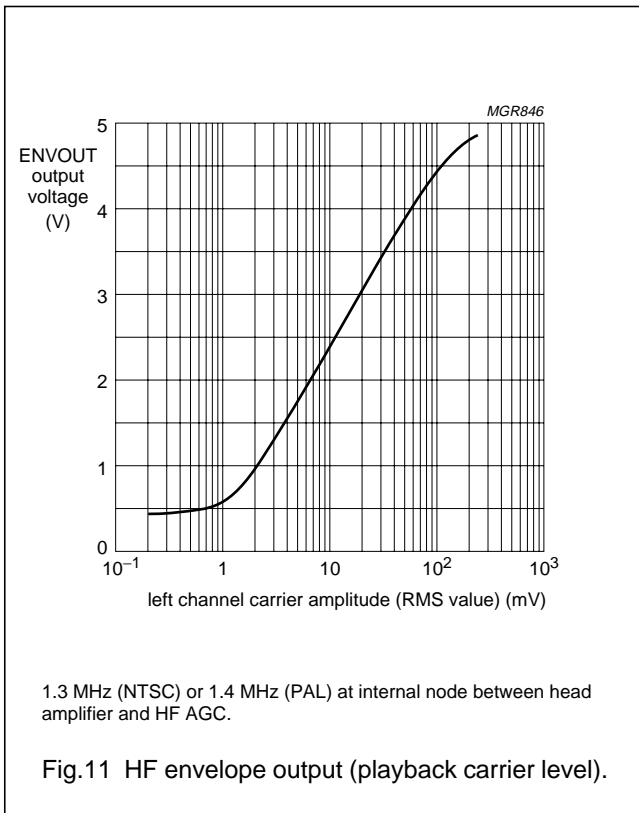

Fig.10 Timing diagram of the envelope output signal.

Audio processor with head amplifier for VHS hi-fi

TDA9605H



6.8 RF converter output

An AGC function is incorporated to avoid overmodulation in the RF converter connected to pin RFCOUT. The AGC limits the maximum signal level on the RF converter output to -3 dBV (see Fig.13).

The RF converter output can be muted by setting bit RFCM = 1. When using this RF converter mute, the AGC control is reset by discharging the capacitor connected to pin RFACG.

Audio processor with head amplifier for VHS hi-fi

TDA9605H

6.9 Audio dubbing

The TDA9605H includes unparalleled functionality supporting the audio dubbing function of hi-fi video recorders. Audio dubbing is a feature which enables the recording of new sound material on the linear audio track (i.e. normal sound) of an existing recording. The dub-mix mode is selected by setting bit IS2 = 1, bit IS1 = 0 and bit IS0 = 1. Audio dubbing can be used in two different ways:

- Output mix
- Input mix.

6.9.1 OUTPUT MIX

A new additional recording is made on the linear audio track. In the playback mode, the new linear audio sound and the original hi-fi sound are combined. In this way the hi-fi stereo quality remains and the linear audio sound is partly used (e.g. for commentary only). However, there is no control over the original hi-fi sound.

Mixing of the hi-fi and normal sound signals in the playback mode is supported by the output select function mix-left, mix-right and mix-stereo (bits OSN, OSR and OSL) and creates a new fixed output signal of $\frac{1}{2} \times$ hi-fi plus $\frac{1}{2} \times$ normal.

6.9.2 INPUT MIX

A new complete recording is made on the linear audio track (see Fig.4). In the playback mode, only the linear audio sound is used. In this way the hi-fi stereo quality is lost, but total freedom in defining the new sound material is an extra advantage. Furthermore, such recording is no longer restricted to playback on hi-fi video recorders (with an output mix option).

The circuit changes into a mixing desk when using the dub-mix mode of the input select function in combination with the volume setting of normal select. A new linear audio recording can be created by mixing together the new and the original sound.

Continuous user control over amplitude and ratio mix of the auxiliary input signal (e.g. a microphone input) and the original hi-fi playback sound is possible using the left and right channel volume controls. This function is realized inside the IC by connecting the auxiliary input signal pair (pins AUXL and AUXR) to the left channel volume control and the hi-fi output signal pair to the right channel volume control.

The settings of the output select function are used to arrange the hi-fi selection and the output signals in the dub-mix mode. However, some of these settings are overruled in the dub-mix mode. The normal signal is available on the line outputs for monitoring the dub-mix recording signals in the output select function modes mix-left, mix-right and mix-stereo.

Mix-stereo of the output select function is generally used for audio dubbing. In combination with the volume setting of normal select, user control over amplitude and ratio is offered for the auxiliary and the hi-fi signal as follows:
 $(\frac{1}{4} \times \text{aux left} + \frac{1}{4} \times \text{aux right}) \times \text{volume left}$ plus
 $(\frac{1}{4} \times \text{hi-fi left} + \frac{1}{4} \times \text{hi-fi right}) \times \text{volume right}$.

The dub-mix mode is to be used in the (hi-fi) playback mode. In the record mode, a signal loop from output to input can be closed which may cause audio oscillation. The auto-normal switching is not active during the dub-mix mode. The hi-fi sound is muted when no hi-fi input signal is detected; bit AUTN is not affected.

Table 5 Dub-mix mode

OUTPUT SELECT MODE	DUB-MIX OUTPUT SELECTION	DUB-MIX INPUT	
		LEFT CHANNEL	RIGHT CHANNEL
mute	mute	aux stereo	mute
hi-fi left	hi-fi left	aux stereo	hi-fi left
hi-fi right	hi-fi right	aux stereo	hi-fi right
hi-fi stereo	hi-fi stereo	aux stereo	hi-fi stereo
normal	normal	aux stereo	mute
mix-left	normal	aux stereo	hi-fi left
mix-right	normal	aux stereo	hi-fi right
mix-stereo	normal	aux stereo	hi-fi stereo

Audio processor with head amplifier for VHS hi-fi

TDA9605H

7 I²C-BUS PROTOCOL

7.1 Addresses and data bytes

Full control of the TDA9605H is accomplished via the 2-wire I²C-bus. Bus speeds up to 400 kbits/s can be used in accordance with the I²C-bus fast-mode specification.

Seven data byte registers are available for programming the device (write mode) and one data byte register is available for reading data from the device (read mode). The registers are addressable via eight subaddresses. Automatic subaddress incrementing enables writing of successive data bytes in one transmission.

During power-up, the data byte registers and auto-calibration registers are reset to a default state by the use of a Power-On Reset (POR) circuit. The reset signal is derived from an internally generated voltage supplied by V_{CC}.

Table 6 Addresses and POR state bits

NAME	ADDRESS	BIT 7	BIT 6	BIT 5	BIT 4	BIT 3	BIT 2	BIT 1	BIT 0
Write mode									
Slave byte	B8H	1	0	1	1	1	0	0	0
Subaddress byte	00H to 07H; note 1	0	0	0	0	0	0 or 1	0 or 1	0 or 1
Control byte POR state	subaddress 00H	AFM 1	DOC 0	SHH 0	DETH 0	NTSC 1	HAC2 0	HAC1 0	HAC0 0
Select byte POR state	subaddress 01H	DOS1 0	DOS0 0	s5 0 ⁽²⁾	HRL 0	NIL3 0	NIL2 0	NIL1 0	NIL0 0
Input byte POR state	subaddress 02H	i7 0 ⁽²⁾	IS2 0	IS1 0	IS0 0	NS2 1	NS1 1	NS0 1	i0 0 ⁽²⁾
Output byte POR state	subaddress 03H	LOH 0	OSN 0	OSR 0	OSL 0	EOS 0	LOS 0	DOS 0	RFCM 1
Left volume byte POR state	subaddress 04H	l7 0 ⁽²⁾	VLS 1	VL5 0	VL4 0	VL3 0	VL2 0	VL1 0	VL0 0
Right volume byte POR state	subaddress 05H	r7 0 ⁽²⁾	VRS 1	VR5 0	VR4 0	VR3 0	VR2 0	VR1 0	VR0 0
Volume byte	subaddress 06H	simultaneous loading of the subaddress 04H and subaddress 05H registers							
Power byte POR state	subaddress 07H	CALS 0	VCCS 0	TEST 0	PORR 0	HPD 0	MUTE 1	STBP 0	STBA 0
Read mode									
Slave address byte	B9H	1	0	1	1	1	0	0	1
Read byte	B9H	CALR	AUTN	CALE	POR	0 ⁽³⁾	0 ⁽³⁾	0 ⁽³⁾	0 ⁽³⁾

Notes

1. Continuous writing to a single data byte register is possible when subaddresses F0H to F7H (1111 0xxx) are used instead of 00H to 07H (0000 0xxx). In that case automatic subaddress incrementing is disabled.
2. It is advised to keep the not-used write bits equal to the POR state to accommodate future compatibility.
3. You cannot rely upon the state of the not-used read bits because their state may change during development.

Audio processor with head amplifier for VHS hi-fi

TDA9605H

7.2 Valid transmissions to and from the TDA9605H

Table 7 Examples of valid transmissions

FUNCTION	DATA TRANSFER SEQUENCE
Write	START, B8H, 00H, data for 00, STOP
Write with auto-increment	START, B8H, 00H, data for 00, data for 01, data for 02, STOP
Write with auto-increment 'wrap-around'	START, B8H, 07H, data for 07, data for 00, data for 01, STOP
Write without auto-increment	START, BBH, F6H, data for 06, data for 06, data for 06, STOP
Read	START, B9H, data from IC, STOP
Read (continued)	START, B9H, data from IC, data from IC, data from IC, STOP

7.3 Overview of the TDA9605H I²C-bus control

Table 8 Condensed overview

FUNCTION	MODES	CONTROL BITS
Audio FM mode	playback and record	AFM
Playback dropout cancelling	on and off	DOC
Playback head switch noise cancel time	6 μ s and 8 μ s	SHH
Playback hi-fi carrier detection time	slow and fast	DETH
Record-mute and carrier ratio select	record-mute, 3, 4.5, 6, 8, 9.5, 11 and 12.5 dB mix ratio	DOC, SHH and DETH
System standard	NTSC and PAL	NTSC
Playback head amplifier amplification	48, 51, 54, 57, 60, 63, 66 and 69 dB	HAC2, HAC1 and HAC0
Record head amplifier current	12.5, 15, 17.5, 21, 25, 30, 35, 42, 50, 60, 71 and 84 mA (p-p)	HAC2, HAC1, HAC0 and HRL
Normal input level	0 to 14 dB and mute	NIL3, NIL2, NIL1 and NIL0
Input select	tuner, CINCH, ext1, ext2, SAP, dub-mix, normal and aux	IS2, IS1 and IS0
Normal select	input select, volume, input-left, volume-left, SAP, tuner, ext2 and mute	NS2, NS1 and NS0
Line output amplification	0 dB and +1 dB	LOH
Output select	mute, left, right, stereo, normal, mix-left, mix-right and mix-stereo	OSN, OSR and OSL
Envelope select	output select, stereo and HF envelope	EOS and AFM
Line select	output select and ext2	LOS
Decoder select	output select, tuner, ext1, SAP and mute	DOS, DOS1 and DOS0
RF converter mute	0 dB AGC and mute	RFCM
Volume left	-47 to 0 dB, mute and 0 to 15 dB	VLS and VL5 to VL0
Volume right	-47 to 0 dB, mute and 0 to 15 dB	VRS and VR5 to VR0
Auto-calibration	off and start calibration	CALS
Supply voltage select	9 V and 12 V	VCCS
Test	standard operating mode and test mode	TEST, HRL, NIL3, NIL2, NIL1 and NIL0

Audio processor with head amplifier for VHS hi-fi

TDA9605H

FUNCTION	MODES	CONTROL BITS
Playback head amplifier disable	standard operating mode and playback disabled	HPD
Power output muting	power mute	MUTE
Operating mode	standard operating mode, active standby and passive standby	STBP and STBA

7.4 Control byte at subaddress 00H

The control byte is used to set the parameters of hi-fi processing and head amplifier control.

7.4.1 AUDIO FM MODE

Bit AFM controls the main mode of the hi-fi processing and head amplifier. The function of other bits of the control byte and bit EOS of the output byte depends on the state of bit AFM.

Table 9 Audio FM mode selection (bit AFM)

AFM	MODE	DESCRIPTION
0	playback	hi-fi processing in playback mode and head amplifier in playback mode
1	record	hi-fi processing in record mode and head amplifier is in record mode or record-mute mode

7.4.2 PLAYBACK MODE

When during the playback mode no FM carrier is detected from tape, the normal audio signal on pin LININ is automatically selected by the output select function.

For this auto-normal mode:

- The timing of the hi-fi carrier detection can be selected via bit DETH which defines the auto-normal release time:
 - Fast mode: hi-fi detection delay is 1 to 2 HID control signal periods (for NTSC: 33 to 66 ms; for PAL: 40 to 80 ms)
 - Slow mode: hi-fi detection delay is 7 to 8 HID control signal periods (for NTSC: 233 to 267 ms; for PAL: 280 to 320 ms).
- The state of hi-fi detection and auto-normal can be monitored by I²C-bus control bit AUTN of the read byte.
- In case automatic selection of the normal audio signal is not required the normal input level control can be set to mute (bits NIL3 to NIL0 of the select byte).

Table 10 Dropout cancelling (bit DOC), sample-and-hold high-state (bit SHH) and detector time hi-fi (bit DETH) in the playback mode; note 1

AFM	DOC	SHH	DETH	MODE	DESCRIPTION
0	0	X	X	playback and DOC off	dropout cancelling disabled
0	1	X	X	playback and DOC on	dropout cancelling active
0	X	0	X	playback and sample-and-hold time = 6 μ s	head switch noise cancel time set to 6 μ s
0	X	1	X	playback and sample-and-hold time = 8 μ s	head switch noise cancel time set to 8 μ s
0	X	X	0	playback and hi-fi detect = fast	fast mode hi-fi detector timing
0	X	X	1	playback and hi-fi detect = slow	slow mode hi-fi detector timing

Note

1. X = don't care.

Audio processor with head amplifier for VHS hi-fi

TDA9605H

7.4.3 RECORD MODE

During the record-mute mode, the recording output current on pin RECOUT is muted and the head amplifier is partly disabled. The record mode, set by I²C-bus control, can also be changed to the record-mute mode by an external control signal on pin RMHID. Sometimes the record-mute mode is named loop-through mode or EE mode.

Table 11 Dropout cancelling (bit DOC), sample-and-hold high-state (bit SHH) and detector time hi-fi (bit DETH) in the record mode

AFM	DOC	SHH	DETH	MODE	DESCRIPTION
1	0	0	0	record-mute	record-mute and no recording output current; note 1
1	0	0	1	record and 3 dB mix	recording with 3 dB output carrier ratio (1 : 1.4)
1	0	1	0	record and 4.5 dB mix	recording with 4.5 dB output carrier ratio (1 : 1.7)
1	0	1	1	record and 6 dB mix	recording with 6 dB output carrier ratio (1 : 2)
1	1	0	0	record and 8 dB mix	recording with 8 dB output carrier ratio (1 : 2.5)
1	1	0	1	record and 9.5 dB mix	recording with 9.5 dB standard output carrier ratio (1 : 3)
1	1	1	0	record and 11 dB mix	recording with 11 dB output carrier ratio (1 : 3.5)
1	1	1	1	record and 12.5 dB mix	recording with 12.5 dB output carrier ratio (1 : 4.2)

Note

1. Power-on reset state.

7.4.4 SYSTEM STANDARD SELECTION

Bit NTSC selects between the NTSC and PAL (SECAM) system carrier frequencies for the CCO modulators or PLL demodulators and the band-pass filters. FM carrier frequencies of 1.3 and 1.7 MHz are used for the NTSC system where 1.4 and 1.8 MHz are used for the PAL system. Different code settings for the auto-calibration circuit assure proper calibration using the standard HID control signal frequency of 29.97 Hz for NTSC mode and 25 Hz for PAL mode. After auto-calibration is completed bit NTSC enables instant switching between the NTSC and PAL system.

Table 12 System standard selection (bit NTSC)

NTSC	MODE	DESCRIPTION
0	PAL	hi-fi circuit in PAL mode
1	NTSC	hi-fi circuit in NTSC mode; note 1

Note

1. Power-on reset state.

Audio processor with head amplifier for VHS hi-fi

TDA9605H

7.4.5 HEAD AMPLIFIER PLAYBACK AMPLIFICATION

Eight settings of playback amplification can be selected for the head amplifier. The amplification values are valid for the head signals from pins PBIN1 or PBIN2 to the internal node between the head amplifier and HF AGC circuit. The setting of the playback amplification results in a selection of the hi-fi detection level (auto-normal function). The hi-fi detection level indicated is the RMS value of the left channel carrier signal on pins PBIN1 and PBIN2.

The signal at the internal node can be monitored for testing purposes via pin ENVOUT using test 8 of the test mode. It should be noted that the output level of test 8 shows 6 dB attenuation compared to the internal node level.

Table 13 Head amplifier control (bits HAC2, HAC1 and HAC0) in the playback mode

AFM	HAC2	HAC1	HAC0	MODE	DESCRIPTION
0	0	0	0	48 dB	hi-fi detection level equals 13 μ V (RMS) from head
0	0	0	1	51 dB	hi-fi detection level equals 9.4 μ V (RMS) from head
0	0	1	0	54 dB	hi-fi detection level equals 6.7 μ V (RMS) from head
0	0	1	1	57 dB	hi-fi detection level equals 4.7 μ V (RMS) from head
0	1	0	0	60 dB	hi-fi detection level equals 3.3 μ V (RMS) from head
0	1	0	1	63 dB	hi-fi detection level equals 2.4 μ V (RMS) from head
0	1	1	0	66 dB	hi-fi detection level equals 1.7 μ V (RMS) from head
0	1	1	1	69 dB	hi-fi detection level equals 1.2 μ V (RMS) from head

7.4.6 HEAD AMPLIFIER RECORD CURRENT

A total of twelve settings of the recording current can be selected for the head amplifier record output pin RECOU. Bit HRL of the select byte selects between high and low current settings. The recording current is defined as the peak-to-peak value of the current of the record output signal which includes both the left and right carrier signal. The selected recording current is independent of the selected record mix ratio setting, but recording is disabled during the record-mute mode as defined by the bits DOC, SHH and DETH or the control signal on pin RMHID.

Table 14 Head amplifier control (bits HAC2, HAC1 and HAC0) and head record current low (bit HRL) in the record mode

AFM	HAC2	HAC1	HAC0	HRL	MODE	DESCRIPTION
1	0	0	0	0	25 mA (p-p)	high recording current is 25 mA (p-p)
1	0	0	1	0	30 mA (p-p)	high recording current is 30 mA (p-p)
1	0	1	0	0	35 mA (p-p)	high recording current is 35 mA (p-p)
1	0	1	1	0	42 mA (p-p)	high recording current is 42 mA (p-p)
1	1	0	0	0	50 mA (p-p)	high recording current is 50 mA (p-p)
1	1	0	1	0	60 mA (p-p)	high recording current is 60 mA (p-p)
1	1	1	0	0	71 mA (p-p)	high recording current is 71 mA (p-p)
1	1	1	1	0	84 mA (p-p)	high recording current is 84 mA (p-p)
1	0	0	0	1	12.5 mA (p-p)	low recording current is 12.5 mA (p-p)
1	0	0	1	1	15 mA (p-p)	low recording current is 15 mA (p-p)
1	0	1	0	1	17.5 mA (p-p)	low recording current is 17.5 mA (p-p)
1	0	1	1	1	21 mA (p-p)	low recording current is 21 mA (p-p)

Audio processor with head amplifier for VHS hi-fi

TDA9605H

7.5 Select byte at subaddress 01H

The select byte is used for decoder output select, record current range select and linear audio volume control.

7.5.1 DECODER OUTPUT SELECT

By setting bit DOS = 0 of the output byte, the decoder output signal on pins DECL and DECR is defined by the output select function. However, by setting bit DOS = 1 the decoder select function enables several independent signal selections controlled via bits DOS1 and DOS0. Via the decoder select function the input signals on pins TUNL and TUNR, pins EXT1L and EXT1R and pin SAP can be selected. The mute mode can also be selected.

The indicated decoder select function modes are also available during the active standby mode by setting bit STBA = 1.

Table 15 Decoder output select (bits DOS1 and DOS0)

DOS1	DOS0	MODE	DESCRIPTION
0	0	tuner	selection of input signal on pins TUNL and TUNR; note 1
0	1	ext1	selection of input signal on pins EXT1L and EXT1R
1	0	SAP	selection of input signal on pin SAP
1	1	mute	muting the input signal

Note

1. Power-on reset state.

7.5.2 HEAD AMPLIFIER RECORD CURRENT RANGE SELECT

The default selection of eight recording currents set by bits HAC2, HAC1 and HAC0 of the control byte is extended with four additional low level recording currents by setting bit HRL = 1.

Table 16 Head amplifier record low current (bit HRL)

HRL	MODE	DESCRIPTION
0	high current	selection of 8 medium and high-level recording currents; note 1
1	low current	selection of 4 low-level recording currents

Note

1. Power-on reset state.

Audio processor with head amplifier for VHS hi-fi

TDA9605H

7.5.3 NORMAL INPUT LEVEL

Fifteen settings of amplification and mute can be selected for the linear audio input signal on pin LININ. The normal input level control can replace the manual adjustment of the playback level at the linear audio circuit.

All selections using the normal linear audio signal include the normal input level control.

Table 17 Normal input level (bits NIL3 to NIL0)

NIL3	NIL2	NIL1	NIL0	MODE	DESCRIPTION
0	0	0	0	0 dB	amplification of linear audio of 0 dB; note 1
0	0	0	1	1 dB	amplification of linear audio of 1 dB
:	:	:	:	:	:
1	1	0	1	13 dB	amplification of linear audio of 13 dB
1	1	1	0	14 dB	amplification of linear audio of 14 dB
1	1	1	1	mute	linear audio signal muted

Note

1. Power-on reset state.

7.6 Input byte at subaddress 02H

The input byte is used for input selection of the hi-fi and linear audio.

7.6.1 INPUT SELECT

The input select function defines the input signal which is forwarded to the volume control function of hi-fi processing and usually via the normal select function to the external linear audio circuit on pin LINOUT.

Table 18 Input select (bits IS2, IS1 and IS0)

IS2	IS1	IS0	MODE	DESCRIPTION
0	0	0	tuner	tuner input signal on pins TUNL and TUNR; note 1
0	0	1	CINCH	CINCH input signal on pins CINL and CINR
0	1	0	ext1	TV input signal on pins EXT1L and EXT1R
0	1	1	ext2	decoder input signal on pins EXT2L and EXT2R
1	0	0	SAP	mono input signal on pin SAP
1	0	1	dub-mix	input signal on pins AUXL and AUXR (for left channel) and from hi-fi output signal (for right channel); note 2
1	1	0	normal	from linear audio circuit (from pin LININ)
1	1	1	aux	input on pins AUXL and AUXR (e.g. camcorder input)

Notes

1. Power-on reset state.
2. The dub-mix mode is a special selection which supports audio dubbing. This video recorder feature enables the recording of the sound signal of the linear audio only (see Section 6.9).

Audio processor with head amplifier for VHS hi-fi

TDA9605H

7.6.2 NORMAL SELECT

The normal select function defines which of the input signals is forwarded to pin LINOUT for the connection to an external linear audio circuit.

Table 19 Normal select (bits NS2, NS1 and NS0)

NS2	NS1	NS0	MODE	DESCRIPTION
0	0	0	input select	left plus right channel signal selected by input select
0	0	1	volume	left plus right channel signal including hi-fi volume control selected by input select
0	1	0	input-left	left channel only (language 1) selected by input select
0	1	1	volume-left	left channel only (language 1) including hi-fi volume control selected by input select
1	0	0	SAP	mono input signal from pin SAP
1	0	1	tuner	tuner input signal from pins TUNL and TUNR
1	1	0	ext2	external input signals from pins EXT2L and EXT2R
1	1	1	mute	mute of the input signals; note 1

Note

1. Power-on reset state.

7.7 Output byte at subaddress 03H

The output byte is used for selecting and controlling the output.

7.7.1 LINE OUTPUT AMPLIFICATION

An additional 1 dB amplification for the line and decoder outputs on pins LINEL, LINER, DECL and DECR can be selected by the line output high function.

Table 20 Line output high (bit LOH)

LOH	MODE	DESCRIPTION
0	0 dB	no line output amplification; note 1
1	1 dB	1 dB line output amplification

Note

1. Power-on reset state.

7.7.2 OUTPUT SELECT

The auto-normal function is activated when no hi-fi signal is found on tape in the playback mode. Except for the mute mode, all output select function modes will be overruled and changed to normal. Control of normal input level should be set to mute for muting the hi-fi sound. The state of the auto-normal function can be monitored by reading bit AUTN of the read byte.

Audio processor with head amplifier for VHS hi-fi

TDA9605H

Table 21 Output select normal, right and left (bits OSN, OSR and OSL)

OSN	OSR	OSL	MODE	DESCRIPTION
0	0	0	mute	mute; no selection; note 1
0	0	1	left	left hi-fi channel selected (language 1)
0	1	0	right	right hi-fi channel selected (language 2)
0	1	1	stereo	hi-fi stereo selected
1	0	0	normal	normal signal selected (linear audio from pin LININ)
1	0	1	mix-left	mix of hi-fi left with normal ($\frac{1}{2} \times \text{left} + \frac{1}{2} \times \text{normal}$)
1	1	0	mix-right	mix of hi-fi right with normal ($\frac{1}{2} \times \text{right} + \frac{1}{2} \times \text{normal}$)
1	1	1	mix-stereo	mix of hi-fi stereo with normal ($\frac{1}{2} \times \text{stereo} + \frac{1}{2} \times \text{normal}$)

Note

1. Power-on reset state.

In case the dub-mix mode is selected via the input select function, the performance of mix-left, mix-right and mix-stereo modes is changed to support audio dubbing input mixing. The hi-fi channel is available for the input select function and normal sound is available at the output for monitoring the linear audio recording. The auto-normal state is ignored during the dub-mix mode and the hi-fi playback signal is muted instead.

Table 22 Dub-mix mode (bits OSN, OSR and OSL)

OSN	OSR	OSL	MODE	OUTPUT IN DUB-MIX MODE	INPUT IN DUB-MIX MODE
0	0	0	mute	mute	mute
0	0	1	left	left channel	left channel
0	1	0	right	right channel	right channel
0	1	1	stereo	stereo signal	$\frac{1}{2} \times \text{left} + \frac{1}{2} \times \text{right}$
1	0	0	normal	normal signal	mute
1	0	1	mix-left	normal signal	left channel
1	1	0	mix-right	normal signal	right channel
1	1	1	mix-stereo	normal signal	$\frac{1}{2} \times \text{left} + \frac{1}{2} \times \text{right}$

7.7.3 ENVELOPE OUTPUT SELECT

The output signal on pin ENVOUT is selected via the envelope select function.

In the playback mode the HF envelope displays the amplitude of the left channel carrier. Display of the right channel carrier amplitude for special measurement purposes can be selected via test 10 in the test mode.

Table 23 Envelope output select (bit EOS)

AFM	EOS	MODE	DESCRIPTION
X ⁽¹⁾	0	output select	audio peak envelope of selected signal via output select function; note 2
0	1	HF envelope	HF envelope of the left channel carrier in the playback mode
1	1	stereo envelope	audio peak envelope of the hi-fi stereo signal in the record mode

Notes

1. X = don't care.
2. Power-on reset state.

Audio processor with head amplifier for VHS hi-fi

TDA9605H

7.7.4 LINE OUTPUT SELECT

An independent selection of the input signals from pins EXT2L and EXT2R to the line outputs on pins LINEL and LINER is offered by the line select function.

In the active standby mode (bit STBA = 1) the output select signal is muted. However, the line select function of the ext2 input signal is still operating.

In combination with the decoder select function a complete pay-TV decoder switching feature is offered via the SCART connector.

Table 24 Line output select (bit LOS)

LOS	MODE	DESCRIPTION
0	output select	line output signal is set by output select; note 1
1	ext2	line output signal is from input signal on pins EXT2L and EXT2R

Note

1. Power-on reset state.

7.7.5 DECODER OUTPUT SELECT

The output signals on pins DECL and DECR can be selected by the decoder select function. By setting bit DOS = 0, the output signals are selected by the output select function. By setting bit DOS = 1, an independent selection between the input signals on pins TUNL and TUNR, pins EXT1L and EXT1R, pin SAP or mute is possible. These signals are selected by the decoder select function (bits DOS1 and DOS2).

In the active standby mode (bit STBA = 1) the output select signal is muted. However, the decoder select function is still operating.

In combination with the line select function a complete pay-TV decoder switching feature is offered via the SCART connector.

Table 25 Decoder output select (bit DOS)

DOS	MODE	DESCRIPTION
0	output select	decoder output signal is set by the output select function; note 1
1	decoder select	decoder output signal is set by the decoder select function

Note

1. Power-on reset state.

7.7.6 RF CONVERTER MUTE

The RF converter output signal on pin RFCOUT can be muted by setting bit RFCM = 1. In this mute mode, the AGC capacitor on pin RFCAGC is discharged and the AGC control is reset.

Table 26 RF converter mute (bit RFCM)

RFCM	MODE	DESCRIPTION
0	AGC	RF converter output signal is set by the output select function: AGC active
1	mute	RF converter output signal is muted and AGC control is reset; note 1

Note

1. Power-on reset state.

7.8 Volume bytes at subaddresses 04H, 05H and 06H

The volume bytes are used to set left and right channel volume control.

7.8.1 Left and right volume control

Left channel volume control can be set by using subaddress 04H. Right channel volume control can be set by using subaddress 05H. Left and right channel volume control can be set simultaneous by using subaddress 06H.

Audio processor with head amplifier for VHS hi-fi

TDA9605H

Table 27 Volume left sign (bit VLS), volume left (bits VL5 to VL0), volume right sign (bit VRS) and volume right (bits VR5 to VR0); note 1

VLS	VL5	VL4	VL3	VL2	VL1	VL0	MODE	DESCRIPTION
VRS	VR5	VR4	VR3	VR2	VR1	VR0		
0	0	0	0	0	0	0	0 dB	volume 0 dB
0	0	0	0	0	0	1	-1 dB	volume -1 dB
0	0	0	0	0	1	0	-2 dB	volume -2 dB
:	:	:	:	:	:	:	:	:
0	1	0	1	1	1	0	-46 dB	volume -46 dB
0	1	0	1	1	1	1	-47 dB	volume -47 dB
0	1	1	X	X	X	X	mute	mute
1	X	X	0	0	0	0	0 dB	volume 0 dB; note 2
1	X	X	0	0	0	1	1 dB	volume 1 dB
1	X	X	0	0	1	0	2 dB	volume 2 dB
:	:	:	:	:	:	:	:	:
1	X	X	1	1	1	0	14 dB	volume 14 dB
1	X	X	1	1	1	1	15 dB	volume 15 dB

Notes

1. X = don't care.
2. Power-on reset state.

7.9 Power byte at subaddress 07H

The power byte is used for power-up settings and the standby control mode.

7.9.1 CALIBRATION START

Automatic frequency calibration by setting the hi-fi modem, the band-pass filter and the noise reduction is performed after a change of bit CALS from logic 0 to logic 1. The use of auto-calibration is only needed after power-up (Power-on reset) of the supply voltage (see Section 6.5).

Table 28 Calibration start (bit CALS)

CALS	MODE	DESCRIPTION
0	no calibration	note 1
1	start calibration	start of the automatic calibration cycle

Note

1. Power-on reset state.

The output signal on pin ENVOUT or bit CALR (calibration ready) and bit CALE (calibration error) of the read byte can be monitored to check for completion of the calibration.

The combination of bit CALR = 1 and bit CALE = 0 indicates a successful calibration. Bit CALS should remain at logic 1 after the calibration to keep a reliable state of bit CALR and bit CALE.

7.9.2 DC OUTPUT VOLTAGE SELECTION

The DC output level on pins LINEL, LINER, DECL and DECR can be changed by setting bit VCCS to maximize the output power when using a supply voltage of 12 V.

The use of power muting (bit MUTE = 1) ensures disturbance free switching of the line output signal when setting bit VCCS after power-up.

Table 29 V_{CC} supply voltage select (bit VCCS)

VCCS	MODE	DESCRIPTION
0	9 V	line and decoder output DC voltage is 4.5 V; note 1
1	12 V	line and decoder output DC voltage is 6 V

Note

1. Power-on reset state.

Audio processor with head amplifier for VHS hi-fi

TDA9605H

7.9.3 TEST MODE

Several special tests can be selected for test, evaluation and measurement purposes. The selection of these tests is made by setting bit HRL and bits NIL3 to NIL0. See Section 14.4 for an overview of the test modes.

Table 30 Test mode (bit TEST)

TEST	MODE	DESCRIPTION
0	operating mode	standard operating; note 1
1	test mode	test mode for special measurements

Note

- 1. Power-on reset state.

7.9.4 POWER-ON RESET

Setting bit PORR = 1 ensures a reset of bit POR of the read byte to logic 0. In this way, a reading of logic 1 for bit POR always indicates the occurrence of an actual I²C-bus register Power-on reset and can not be caused accidentally by other I²C-bus control bits. Bit PORR has no control function but it is an unused bit, dedicated by name to change the I²C-bus register content from the Power-on reset state.

Bit POR of the read byte is a logic AND function for checking all I²C-bus register bits. Bit POR will read logic 1 when the I²C-bus register content equals the Power-on reset default state and also when this state is set via the I²C-bus control. Since a setting of bit PORR = 1 differs from the Power-on reset default state, it forces a reset of bit POR to logic 0 independent of other bit settings.

Table 31 Resetting of bit POR (bit PORR)

PORR	MODE	DESCRIPTION
0	no reset	note 1
1	bit POR reset	reset of bit POR (read byte)

Note

- 1. Power-on reset state.

7.9.5 HEAD AMPLIFIER DISABLE

Bit HPD offers a special setting intended for use with some of the built-in test modes and for support of particular applications that do not require use of the integrated head amplifier. By setting bit HPD = 1 the head amplifier playback circuit is disabled. This mode enables direct input signal to the HF AGC circuit via pin HMSW (AC coupled via a 10 nF capacitor).

Table 32 Head amplifier playback disable (bit HPD)

HPD	MODE	DESCRIPTION
0	operating mode	standard operating mode; note 1
1	head amplifier disable	head amplifier disabled in playback mode (for test or special application)

Note

- 1. Power-on reset state.

7.9.6 POWER MUTING

The power mute function controls the mute switches on the line and RF converter outputs. The power mute mode is automatically activated via the Power-on reset function during power-up of the supply voltage. During power-down, the mute switches are activated automatically by means of the auto-mute circuit which is independent of the setting of bit MUTE. When setting bit MUTE = 1 the output current on pins RFCOUT, LINEL, LINER, DECL and DECR is limited to -1 mA for controlled power-up response and the selected output signal is muted (see Section 6.6).

Table 33 Power mute (bit MUTE)

MUTE	MODE	DESCRIPTION
0	no mute	power muting released: mute switches are open
1	mute	power muting activated: mute switches are closed; note 1

Note

- 1. Power-on reset state.

Audio processor with head amplifier for VHS hi-fi

TDA9605H

7.9.7 STANDBY SELECT

The TDA9605H is switched in the low-power active standby mode by setting bit STBA = 1. Most circuits are switched inactive for reducing power consumption. However, the RF converter, line and decoder outputs remain active in this mode and the direct audio selections offered via the line select function and the decoder select function remain available. The selected output signal is muted during the active standby mode.

The TDA9605H is switched in the minimum power passive standby mode by setting bit STBP = 1. All circuits are switched inactive to obtain minimum power consumption except for the power mute circuit, the I²C-bus and the line input reference buffer (i.e. the DC voltage on pins 1 to 11 remains active). When bit STBP = 1 a discharge current of 1 mA is active on pins RFCOUT, LINEL, LINER, DECL and DECR.

Power muting ensures disturbance-free switching of the line and RF converter outputs to and from the passive standby mode. In the passive standby mode power muting can be de-activated again to achieve minimum power consumption. The calibration and I²C-bus registers are not affected in the active standby or passive standby mode.

Table 34 Standby passive (bit STBP) and standby active (bit STBA); note 1

STBP	STBA	MODE	DESCRIPTION
0	0	operating	standard operating mode: full function; note 2
0	1	active standby	active standby mode: reduced power consumption
1	X	passive standby	passive standby mode: minimum power consumption

Notes

1. X = don't care.
2. Power-on reset state.

7.10 Read byte

The read byte is used for reading the device state information.

7.10.1 CALIBRATION READY

The completion of calibration is signalled by changing bit CALR from logic 0 to logic 1. Bit CALR remains logic 0 if for some reason a calibration can not be completed (i.e. no HID control signal available or the hi-fi processing is in the playback mode). Bit CALR will also return to logic 0 if calibration is lost due to a Power-on reset situation.

Additional information about the calibration result is available via bit CALE. Calibration is found correct if bit CALR = 1 and bit CALE = 0.

Pin ENVOUT can also be used to monitor calibration (see Section 6.5).

Table 35 Calibration ready (bit CALR)

CALR	DESCRIPTION
0	not calibrated; note 1
1	auto-calibration completed

Note

1. Power-on reset state.

7.10.2 AUTO-NORMAL SELECTION

The auto-normal function is activated when no hi-fi carrier input signal is detected in the playback mode.

The auto-normal function overrules the settings of the output select function and selects normal sound (i.e. linear audio) instead of hi-fi. The state of the auto-normal function can be checked by reading bit AUTN.

The auto-normal function and therefore bit AUTN is only valid in the playback mode. Bit AUTN is always logic 0 in the record mode.

Table 36 Auto-normal (bit AUTN)

AUTN	DESCRIPTION
0	hi-fi carrier available; audio FM signal is detected from tape in playback mode; note 1
1	normal sound selected instead of hi-fi carrier; no audio FM signal is detected from tape

Note

1. Power-on reset state.

Audio processor with head amplifier for VHS hi-fi

TDA9605H

7.10.3 CALIBRATION ERROR

An unreliable calibration result is indicated when reading bit CALE = 1. The calibration result is not reliable when during calibration the control signal on pin RMHID is disturbed due to an external cause. Such a disturbance of the HID control signal is detected when reading bit CALE = 1. A new calibration should be started to ensure proper calibration.

Calibration is found correct when bit CALR = 1 and bit CALE = 0.

Table 37 Calibration error (bit CALE)

CALE	DESCRIPTION
0	not calibrated or calibration result is found correct; note 1
1	calibration error encountered during calibration

Note

1. Power-on reset state.

7.10.4 POWER-ON RESET

An internal Power-on reset signal is generated at power-up or during a power voltage dip. The I²C-bus data bits and auto-calibration registers are reset to a pre-defined state. When reading bit POR = 1, it indicates that the internal data bits are found to be in the POR state due to an actual Power-on reset or the I²C-bus control settings.

Detecting the occurrence of a Power-on reset by reading bit POR requires a setting of bit PORR = 1 after power-up. Bit POR is forced to logic 0 only by setting bit PORR = 1, so this setting is independent of other I²C-bus bit settings.

After calibration a Power-on reset occurrence is also indicated by bit CALR = 0, because calibration will be lost.

Table 38 Power-on reset (bit POR)

POR	DESCRIPTION
0	I ² C-bus bit state differs from the Power-on reset state
1	I ² C-bus bit state equals the Power-on reset state; note 1

Note

1. Power-on reset state.

Audio processor with head amplifier for VHS hi-fi

TDA9605H

8 LIMITING VALUES

In accordance with the Absolute Maximum Rating System (IEC 134).

SYMBOL	PARAMETER	CONDITIONS	MIN.	MAX.	UNIT
V _{CC}	supply voltage		0	13.2	V
V _{CCH}	head amplifier supply voltage		0	5.5	V
T _{stg}	storage temperature		-65	+150	°C
T _{amb}	operating ambient temperature		0	70	°C
V _{es}	electrostatic handling voltage	machine model	-300	+300	V
		human body model	-3000	+3000	V
I _{lu(prot)}	latch-up protection current on pin HSMW pin SDA all other pins	T _j = 100 °C	-70	+100	mA
			-60	+100	mA
			-100	+100	mA

9 THERMAL CHARACTERISTICS

SYMBOL	PARAMETER	CONDITIONS	VALUE	UNIT
R _{th(j-a)}	thermal resistance from junction to ambient	in free air	60	K/W

10 GENERAL CHARACTERISTICS

SYMBOL	PARAMETER	CONDITIONS	MIN.	TYP.	MAX.	UNIT
Supplies						
V _{CC}	supply voltage	VCCS = 0	8.1	9	13.2	V
		VCCS = 1	8.1	12	13.2	V
V _{CCH}	head amplifier supply voltage		4.75	5	5.5	V
I _{CC}	supply current	standard operating mode	-	36	48	mA
		active standby (STBA = 1)	-	8	12	mA
		passive standby (STBP = 1)	-	4	6	mA
I _{CCH}	head amplifier supply current	playback mode	-	21	28	mA
		record-mute mode	-	18	24	mA
		record mode (HAC = 000)	-	23	31	mA
		record mode (HAC = 011)	-	35	47	mA
		record mode, (HAC = 111)	-	67	89	mA
		active or passive standby (STBA = 1 or STBP = 1)	-	0	-	mA

Audio processor with head amplifier for VHS hi-fi

TDA9605H

SYMBOL	PARAMETER	CONDITIONS	MIN.	TYP.	MAX.	UNIT
Internally generated voltage levels						
V _{n1}	DC voltage on pins SAP, TUNL, TUNR, CINL, CINR, EXTL1, EXTLR, AUXL, AUXR, LININ and RFCOUT		–	3.8	–	V
V _{n2}	DC voltage on pin LINOUT		–	4.5	–	V
V _{n3}	DC voltage on pins LINEL, LINER, DECL and DECR	V _{CC} = 9 V (VCCS = 0)	–	4.5	–	V
		V _{CC} = 12 V (VCCS = 1)	–	6	–	V
Control signal input: pin RMHID						
V _i	input voltage	record or record-mute with I ² C-bus control (RM = LOW) for head 2 (HID = LOW) for head 1 (HID = HIGH)	0	–	0.6	V
			1.0	–	2.35	V
		record-mute (RM = HIGH) for head 2 (HID = LOW) for head 1 (HID = HIGH)	2.65	–	3.8	V
			4.3	–	5.5	V

11 RECORD-MUTE MODE CHARACTERISTICS

V_{CC} = 12 V; T_{amb} = 25 °C; tuner audio input level –8 dBV at f = 1 kHz; Power-on reset state with output select = stereo; bit RFCM = 0; bit MUTE = 0; auto-calibrated; measured in typical application circuit of Fig.14; unless otherwise specified.

SYMBOL	PARAMETER	CONDITIONS	MIN.	TYP.	MAX.	UNIT
Line inputs: pins SAP, TUNL, TUNR, CINL, CINR, EXT1L, EXT1R, EXT2L, EXT2R, AUXL and AUXR						
V _i	input voltage		–	–	9	dBV
R _i	input impedance		100	130	–	kΩ
Linear audio input: pin LININ						
V _i	input voltage		–	–	8	dBV
R _i	input impedance		100	130	–	kΩ
Linear audio output: pin LINOUT						
V _o	output voltage		–9	–8	–7	dBV
R _o	output impedance		–	200	300	Ω
Line and decoder outputs: pins LINEL, LINER, DECL and DECR						
V _o	output voltage	normal output (LOH = 0)	–9	–8	–7	dBV
		output = 1 dB (LOH = 1)	–8	–7	–6	dBV
V _{o(max)}	maximum output voltage	V _{CC} = 9 V; note 1	7	8	–	dBV
		V _{CC} = 12 V; note 1	10	11	–	dBV
I _{o(dch)}	discharge output current	passive standby (STBP = 1)	–	1	–	mA
I _{o(max)}	output current limiting	power mute (MUTE = 1)	–	–1	–	mA
R _o	output impedance		–	100	150	Ω
THD	total harmonic distortion		–	0.01	0.1	%

Audio processor with head amplifier for VHS hi-fi

TDA9605H

SYMBOL	PARAMETER	CONDITIONS	MIN.	TYP.	MAX.	UNIT
α_{cb}	channel balance		-1	0	+1	dB
V_n	noise level	tuner input signal at zero level $-\infty$ dBV; note 2	-	-94	-90	dBV
$\alpha_{mute(v)}$	mute volume	volume bytes left and right set to mute mode	-	-96	-70	dB
$\alpha_{mute(o)}$	mute output	output select bits set to mute mode	-	-86	-70	dB
$\alpha_{ct(ch)}$	crosstalk between channels	one of tuner input signals at zero level $-\infty$ dBV	-	-90	-70	dB
$\alpha_{ct(ch)(i)}$	crosstalk between input channels	note 3	-	<-93	-	dB
RF converter output: pin RFCOUT						
V_o	output voltage	tuner input signal at normal level -8 dB	-9	-8	-7	dBV
		high level 8 dBV	-4.5	-3	-1.5	dBV
THD	total harmonic distortion	tuner input signal at normal level -8 dBV	-	0.03	-	%
		levels from -8 to +8 dBV	-	<0.2	-	%
V_n	noise level	tuner input signal on zero level $-\infty$ dBV; note 2	-	-80	-	dBV
R_o	output impedance		-	200	300	Ω
$I_{o(max)}$	output current limiting	power mute (MUTE = 1)	-	-1	-	mA
I_o	discharge output current	passive standby (STBP = 1)	-	1	-	mA
Power mute outputs: pins MUTE_C, MUTE_L and MUTE_R						
R_o	output impedance	no mute (MUTE = 0)	50	100	-	k Ω
		muting (MUTE = 1); DC load from -1 to +1 mA	-	15	-	Ω
Audio peak envelope output: pin ENVOU_T						
V_o	output voltage	tuner input signal at normal level -8 dBV	1.65	1.8	1.96	V
		at high level +8 dBV	4.0	4.5	5.0	V
		at zero level $-\infty$ dBV	-	-	0.3	V
		at zero level $-\infty$ dBV and maximum volume +15 dB	-	-	0.35	V
α_{cb}	channel balance		-0.11	0	+0.11	V
R_o	output impedance		-	1	1.5	k Ω

Notes

- THD = 1%, output load with $R_L = 5$ k Ω and $C_L = 2.2$ nF, volume = 3 dB for $V_{CC} = 12$ V and tuner input level varied.
- B = 20 Hz to 20 kHz, unweighted.
- Crosstalk of any line input pair (tuner, CINCH, ext1, ext2, aux and SAP) to any other line input.

Audio processor with head amplifier for VHS hi-fi

TDA9605H

12 RECORD MODE CHARACTERISTICS

$V_{CC} = 12\text{ V}$; $T_{amb} = 25\text{ °C}$; tuner audio input level -8 dBV at $f = 1\text{ kHz}$; auto-calibrated; measured in typical application circuit of Fig.14; unless otherwise specified.

SYMBOL	PARAMETER	CONDITIONS	MIN.	TYP.	MAX.	UNIT
Noise reduction (test 25b)						
THD	total harmonic distortion	tuner input signal at normal level -8 dBV	–	0.1	0.3	%
		high level $+8\text{ dBV}$	–	0.2	1.0	%
α_{cb}	channel balance		–1	0	+1	dB
α_{lin}	linearity	tuner input signal at low level $-68\text{ to }-8\text{ dBV}$	–32	–30.5	–29	dB
		high level $-8\text{ to }+8\text{ dBV}$	7.5	8	8.5	dB
α_n	noise level with respect to signal level	tuner input signal level from $-\infty$ to -8 dBV ; note 1	–	–46	–41	dB
t_{att}	attack time	in accordance with VHS specification	–	5	–	ms
t_{rec}	recovery time	in accordance with VHS specification	–	70	–	ms
$\alpha_{res(f1)}$	frequency response 300 Hz	tuner input frequency from 300 to 1000 Hz	–0.7	–0.2	+0.3	dB
$\alpha_{res(f2)}$	frequency response 10 kHz	tuner input frequency from 10 to 1 kHz	3.1	3.9	4.7	dB
$\alpha_{res(lpf1)}$	audio low-pass filter response 20 kHz	tuner input frequency from 20 to 1 kHz; test 26b	–0.5	–0.1	+0.5	dB
$\alpha_{res(lpf2)}$	audio low-pass filter response 60 kHz	tuner input frequency from 60 to 1 kHz; test 26b	–	–24	–12	dB
FM modulator						
THD	total harmonic distortion	$\Delta f_{FM} = 50\text{ kHz}$; test 25a and 26a	–	0.1	0.2	%
$\Delta f_{FM(max)}$	maximum FM deviation of clipper	test 25a and 26a	140	150	160	kHz
$f_{c(acc)}$	carrier frequency accuracy	auto-calibration	–5	0	+5	kHz
Δf_c	carrier frequency difference	$f_{c(R)} - f_{c(L)}$ for NTSC auto-calibration	399.2	401.2	403.2	kHz
$f_{c(shift)}$	carrier frequency shift	NTSC/PAL system switching	97	100	103	kHz
TC	temperature coefficient		–	± 50	–	ppm/K
Noise reduction and FM modulator						
Δf_{FM}	FM deviation		44.5	50	56.1	kHz
Record output on pin RECOUT						
$I_{o(acc)}$	output current accuracy	left and right carrier 1st harmonic	–1.5	0	+1.5	dB
$\alpha_{f(acc)}$	carrier mix ratio accuracy	left compared to right carrier	–1	0	+1	dB
α_{IM2}	IM2 product	note 2	–	–66	–	dB

Notes

1. $B = 20\text{ Hz to }20\text{ kHz}$, unweighted.
2. Amplitude of 400 kHz intermodulation product $f_{c(R)}$ and $f_{c(L)}$ compared to amplitude of recording current $f_{c(R)} + f_{c(L)}$.

Audio processor with head amplifier for VHS hi-fi

TDA9605H

13 PLAYBACK MODE CHARACTERISTICS $V_{CC} = 12\text{ V}$; $T_{amb} = 25\text{ °C}$; measured in typical application circuit of Fig.14; unless otherwise specified.

SYMBOL	PARAMETER	CONDITIONS	MIN.	TYP.	MAX.	UNIT
Play back input on pins PBIN2 and PBIN1						
R_i	input resistance		–	700	–	Ω
C_i	input capacitance		–	35	–	pF
$V_{n(i)}$	input noise voltage		–	0.5	–	nV/ $\sqrt{\text{Hz}}$
$I_{n(i)}$	input noise current		–	2.5	–	pA/ $\sqrt{\text{Hz}}$
Head mode switch: pin HSMW						
R_i	input impedance	with respect to ground	–	1	2	Ω
Head amplifier						
G_{acc}	gain accuracy	test 8	–3	0	+3	dB
G_{bal}	gain balance	between pins PBIN1 and PBIN2	–1	0	+1	dB
α_{ct}	head-to-head crosstalk	between pins PBIN1 and PBIN2	–	–45	–	dB
HF AGC (test 5)						
$V_{i(p-p)}$	AGC start level (peak-to-peak value)	playback mode (HPD = 1); left plus right channel	47	67	94	mV
B	control bandwidth	note 1	–	10	–	kHz
Left channel band-pass filter (test 3)						
α_f	output voltage ratio	$(f_0 - 400\text{ kHz})/f_0$	–	–30	–20	dB
		$(f_0 - 150\text{ kHz})/f_0$	–9	–6	–	dB
		$(f_0 + 150\text{ kHz})/f_0$	–9	–5	–	dB
		$(f_0 + 250\text{ kHz})/f_0$	–	–17	–12	dB
		$(f_0 + 250\text{ kHz})/(f_0 + 150\text{ kHz})$	–	–12	–9	dB
		$(f_0 + 400\text{ kHz})/f_0$	–	–	–30	dB
$t_{d(g)}$	ripple group delay	$(f_0 - 150\text{ kHz})$ to $(f_0 + 150\text{ kHz})$	–	0.5	–	μs
Right channel band-pass filter (test 4)						
α_f	output voltage ratio	$(f_0 - 400\text{ kHz})/f_0$	–	–	–30	dB
		$(f_0 - 250\text{ kHz})/f_0$	–	–17	–10	dB
		$(f_0 - 250\text{ kHz})/(f_0 - 150\text{ kHz})$	–	–12	–9	dB
		$(f_0 - 150\text{ kHz})/f_0$	–9	–5	–	dB
		$(f_0 + 150\text{ kHz})/f_0$	–9	–6	–	dB
		$(f_0 + 400\text{ kHz})/f_0$	–	–30	–20	dB
$t_{d(g)}$	ripple group delay	$(f_0 - 150\text{ kHz})$ to $(f_0 + 150\text{ kHz})$	–	0.5	–	μs

Audio processor with head amplifier for VHS hi-fi

TDA9605H

SYMBOL	PARAMETER	CONDITIONS	MIN.	TYP.	MAX.	UNIT
Hi-fi detector (bit AUTN)						
$V_{th(rms)}$	threshold level (RMS value)	playback mode (HPD = 1); left channel carrier	2.4	3.3	4.6	mV
$V_{th(acc)}$	accuracy of threshold level	left channel carrier on pins PBIN1 and PBIN2	-5	0	+5	dB
$t_{d(sw)}$	switch-on delay	carrier to no-carrier	150	300	500	μ s
Hi-fi dropout cancelling (bit DOC)						
V_{th}	threshold level	with respect to threshold level of bit AUTN	-7	-4	-2	dB
$t_{d(sw)}$	switch-off delay	no-carrier to carrier	5	9	14	μ s
Head switching noise suppression						
t_h	hold time	sample-and-hold time bit SHH = 0	5	6	7	μ s
		sample-and-hold time bit SHH = 1	7	8	9	μ s
THD	total harmonic distortion	test 25c; note 2	-	-	-73	dB
t_d	delay	between HID control signal and hold status	-	0.3	-	μ s
PLL FM demodulator (test 25c)						
V_i	sensitivity	$\Delta f_{FM} = 150$ kHz; S/N = 35 dB	-	0.3	1	mV
THD	total harmonic distortion	normal; $\Delta f_{FM} = 50$ kHz	-	0.05	0.3	%
		maximum; $\Delta f_{FM} = 150$ kHz	-	0.2	1.5	%
S/N	signal-to-noise ratio	$\Delta f_{FM} = 50$ to 0 kHz	54	60	-	dB
$\alpha_{ct(ch)}$	channel crosstalk	left or right carrier; $\Delta f_{FM} = 0$ kHz	-	-80	-	dB
Noise reduction (test 26c)						
V_n	noise level	tuner input signal level at $-\infty$ dBV; note 3	-	-95	-90	dBV
THD	total harmonic distortion	tuner input signal level at -6.5 dBV	-	0.05	0.2	%
α_{lin}	linearity	tuner input signal level from -6.5 to -36.5 dBV	58	59.6	62	dB
$\alpha_{res(f1)}$	frequency response 300 Hz	tuner input frequency from 300 to 1000 Hz	-0.6	+0.4	+1.4	dB
$\alpha_{res(f2)}$	frequency response 10 kHz	tuner input frequency from 10 to 1 kHz	-9.2	-7.7	-6.2	dB

Audio processor with head amplifier for VHS hi-fi

TDA9605H

SYMBOL	PARAMETER	CONDITIONS	MIN.	TYP.	MAX.	UNIT
Envelope output: pin ENVOUT						
V_o	output voltage	left channel input signal at				
		1.6 mV (RMS)	0.6	0.9	1.2	V
		16 mV (RMS)	2.5	2.9	3.3	V
		160 mV (RMS)	4.2	4.7	5.0	V
FM demodulator and noise reduction: pins LINEL and LINER						
V_o	output voltage		-10	-8	-6	dBV
α_{cb}	channel balance		-1.5	0	+1.5	dB

Notes

1. Amplitude modulated single carrier signal of 60 mV (RMS) on pin HMSW; for playback mode HPD = 1. Control bandwidth is defined as the modulation frequency at which the amplitude modulation is attenuated with 3 dB by the HF AGC.
2. Sample-and-hold audio distortion is measured using a HID control signal of 500 Hz on pin RMHID, $f_{mod} = 10$ kHz and $\Delta f_{FM} = 50$ kHz. Audio distortion is measured using a 3 kHz 4th-order low-pass filter. The measured value is corrected with 24 dB in order to calculate the equivalent distortion for the standard NTSC 29.97 Hz HID control signal.
3. B = 20 Hz to 20 kHz, unweighted.

Audio processor with head amplifier for VHS hi-fi

TDA9605H

14 APPLICATION AND TEST INFORMATION

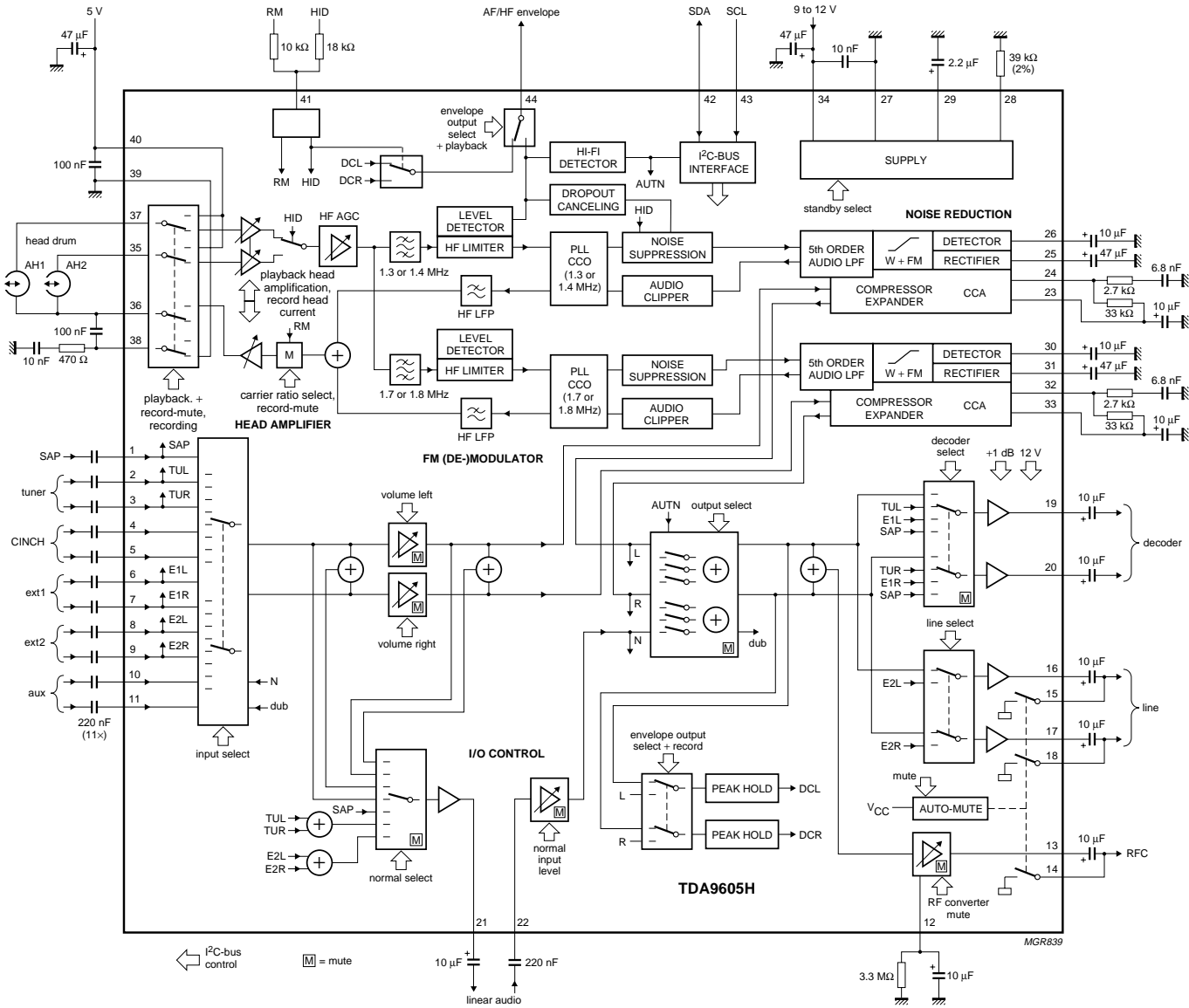

Fig.14 Application diagram.

Audio processor with head amplifier for VHS hi-fi

TDA9605H

14.1 RM and HID control signals

To assure proper input conditions on pin RMHID the RM and HID control signals (see Fig.15) should satisfy the requirements given in Table 39.

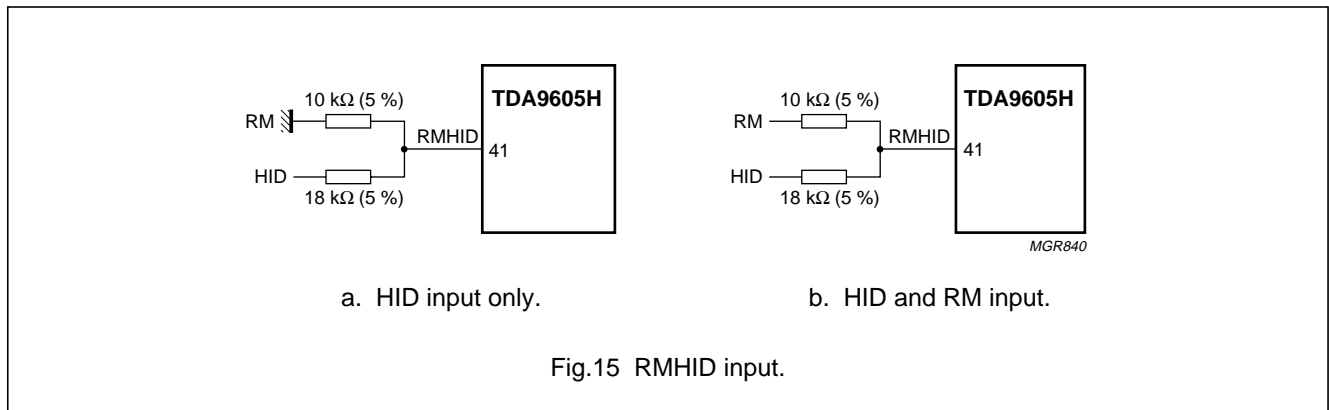

Table 39 Conditions of RM and HID input signal

SIGNAL	HID INPUT SIGNAL ONLY			HID AND RM INPUT SIGNALS		
	CONDITIONS	MIN.	MAX.	CONDITIONS	MIN.	MAX.
HID	LOW	0 V	1.5 V	LOW	0 V	0.4 V
	HIGH	3 V	5.5 V	HIGH	4.3 V	5.5 V
RM	grounded	-	-	LOW	0 V	0.4 V
				HIGH	4.3 V	5.5 V

14.2 Reference current resistor

The requirements for the reference current resistor on pin 28 are:

- R = 39 kΩ ±2%
- Temperature coefficient = ±50 ppm/°C.

Audio processor with head amplifier for VHS hi-fi

TDA9605H

14.3 Setting line output level

The audio level can be set by selecting the external filter components connected to the emphasis noise reduction pins 24 and 32 (pins EMPHL and EMPHR).

Table 40 Component values for setting the line output level

LINE OUTPUT LEVEL ⁽¹⁾	RESISTOR CONNECTED BETWEEN		RESISTOR IN SERIES WITH CAPACITOR CONNECTED BETWEEN			
	PINS 24 AND 23	PINS 32 AND 33	PIN 24 AND GROUND		PIN 32 AND GROUND	
-4.9 dBV	47 k Ω	47 k Ω	3.9 k Ω	4.7 nF	3.9 k Ω	4.7 nF
-5.7 dBV	43 k Ω	43 k Ω	3.6 k Ω	5.1 nF	3.6 k Ω	5.1 nF
-6.4 dBV	39 k Ω	39 k Ω	3.3 k Ω	5.6 nF	3.3 k Ω	5.6 nF
-7.2 dBV	36 k Ω	36 k Ω	3.0 k Ω	6.2 nF	3.0 k Ω	6.2 nF
-8.0 dBV	33 k Ω	33 k Ω	2.7 k Ω	6.8 nF	2.7 k Ω	6.8 nF
-8.8 dBV	30 k Ω	30 k Ω	2.4 k Ω	7.5 nF	2.4 k Ω	7.5 nF
-9.6 dBV	27 k Ω	27 k Ω	2.2 k Ω	8.2 nF	2.2 k Ω	8.2 nF
-10.6 dBV	24 k Ω	24 k Ω	2.0 k Ω	9.1 nF	2.0 k Ω	9.1 nF
-11.4 dBV	22 k Ω	22 k Ω	1.8 k Ω	10 nF	1.8 k Ω	10 nF

Note

- Standard 50 kHz FM deviation at $f = 1$ kHz.

14.4 Test modes

Special test modes are implemented for testing, evaluation and measurement purposes. These test modes are available when bit TEST = 1 and the test select function is enabled via five bits of the select byte (see Table 41). When selecting test modes the normal input level setting is changed as defined by bits NIL3 to NIL0. Calibration may be lost when a not listed test mode is selected.

Audio processor with head amplifier for VHS hi-fi

TDA9605H

Table 41 Test modes for evaluation and measurement purposes

TEST	HRL	NIL3	NIL2	NIL1	NIL0	MODE	DESCRIPTION
1	0	0	0	0	1	test 1	record mode; left channel FM carrier only (1.3 or 1.4 MHz)
1	0	0	0	1	0	test 2	record mode; right channel FM carrier only (1.7 or 1.8 MHz)
1	0	0	0	1	1	test 3	playback mode; left channel band-pass filter with HF AGC off; EOS = 1 (test output on pin ENVOUT); notes 1 and 2
1	0	0	1	0	0	test 4	playback mode; right channel band-pass filter with HF AGC off; EOS = 1 (test output on pin ENVOUT); notes 1 and 2
1	0	0	1	0	1	test 5	playback mode; HF AGC (left channel band-pass filter); EOS = 1 (test output on pin ENVOUT); notes 1 and 2
1	0	0	1	1	0	test 6	playback mode; HF AGC (right channel band-pass filter); EOS = 1 (test output on pin ENVOUT); notes 1 and 2
1	0	1	0	0	0	test 8	playback mode; head amplifier output signal; EOS = 1 (test output on pin ENVOUT); notes 2 and 3
1	0	1	0	1	0	test 10	playback mode; HF envelope of right channel carrier; EOS = 1 (test output on pin ENVOUT)
1	1	1	0	0	1	test 25	noise reduction and modem; note 4
						test 25a	left channel FM modulator (left carrier only); record mode; volume setting = -3 dB; test input = line input left
						test 25b	left and right noise reduction (compressor); record mode; output select function = mute; test output = line output
						test 25c	left and right channel FM demodulator; playback mode; output select function = mute; test output = line output
1	1	1	0	1	0	test 26	noise reduction and modem; note 4
						test 26a	right channel FM modulator (right carrier only); record mode; volume setting = -3 dB; test input = line input right
						test 26b	left and right channel audio lowpass filter; record mode; volume setting = -3 dB; output select function = mute; test input = line input; test output = line output
						test 26c	left and right channel noise reduction (expander); playback mode; volume setting = -3 dB; test input = line input; note 5

Notes

1. This test can be used with a HIGH-level input signal by setting bit HPD = 1; test input signal applied to pin HMSW.
2. Auto-normal is activated (bit AUTN = 1) during the test, i.e. the playback audio signal is not available.
3. The output level on pin ENVOUT shows 6 dB attenuation compared to the internal signal of the head amplifier output.
4. This test connects internal signal lines between the noise reduction and (de-)modulator circuit. The signals found here are not compensated for temperature or tolerance spread and therefore level measurements are only relative. Absolute values are not an indication of the overall performance. Typical audio level of the test inputs and outputs is approximately -6.5 dBV for the standard -8 dBV line level and 50 kHz FM deviation.
5. The expander test requires the auto-normal function to be set inactive; i.e. an FM carrier signal should be available.

Audio processor with head amplifier for VHS hi-fi

TDA9605H

15 INTERNAL CIRCUITRY

The indicated DC voltages are given for the record-mute mode in the typical application circuit without audio signal; unless otherwise specified.

PIN	SYMBOL	VOLTAGE	EQUIVALENT CIRCUIT
1	SAP	3.8 V	<p>MGR849</p>
2	TUNL		
3	TUNR		
4	CINL		
5	CINR		
6	EXT1L		
7	EXT1R		
8	EXT2L		
9	EXT2R		
10	AUXL		
11	AUXR		
12	RFCAGC	0 V	<p>MGR850</p>
13	RFCOUT	3.8 V	<p>MGR851</p>
14	MUTEC	0 V	<p>bit MUTE or $V_{CC} < 7 V$</p> <p>MGR852</p>
15	MUTEL		
18	MUTER		
16	LINEL	4.5 V ($V_{CCS} = 0$); 6 V ($V_{CCS} = 1$)	<p>MGR853</p>
17	LINER		
19	DECL		
20	DECR		

Audio processor with head amplifier for VHS hi-fi

TDA9605H

PIN	SYMBOL	VOLTAGE	EQUIVALENT CIRCUIT
21	LINOUT	4.5 V	
22	LININ	3.8 V	
23	DCFBL	3.8 V	
33	DCFBR		
24	EMPHL	3.8 V	
32	EMPHR		
25	DCL	3.8 V	
31	DCR		

Audio processor with head amplifier for VHS hi-fi

TDA9605H

PIN	SYMBOL	VOLTAGE	EQUIVALENT CIRCUIT
26	DETL	0.7 V	
30	DETR		
27	GND	0 V	
28	I _{ref}	3.8 V	
29	V _{ref}		
34	V _{CC}	9 to 12 V	

Audio processor with head amplifier for VHS hi-fi

TDA9605H

PIN	SYMBOL	VOLTAGE	EQUIVALENT CIRCUIT
35	PBIN2	0.7 V; 4.3 V (recording)	
36	RECOUT		
37	PBIN1		
38	HMSW	0 V; 4.3 V (recording)	
39	GNDH	0 V	<p>MGR864</p>
40	V _{CCH}	5 V	<p>MGR865</p>

Audio processor with head amplifier for VHS hi-fi

TDA9605H

PIN	SYMBOL	VOLTAGE	EQUIVALENT CIRCUIT
41	RMHID	0 to 5 V	
42	SDA	0 or 5 V	
43	SCL	0 or 5 V	
44	ENVOUT	0 V	

Audio processor with head amplifier for VHS hi-fi

TDA9605H

16 PACKAGE OUTLINE

QFP44: plastic quad flat package; 44 leads (lead length 1.3 mm); body 10 x 10 x 1.75 mm

SOT307-2

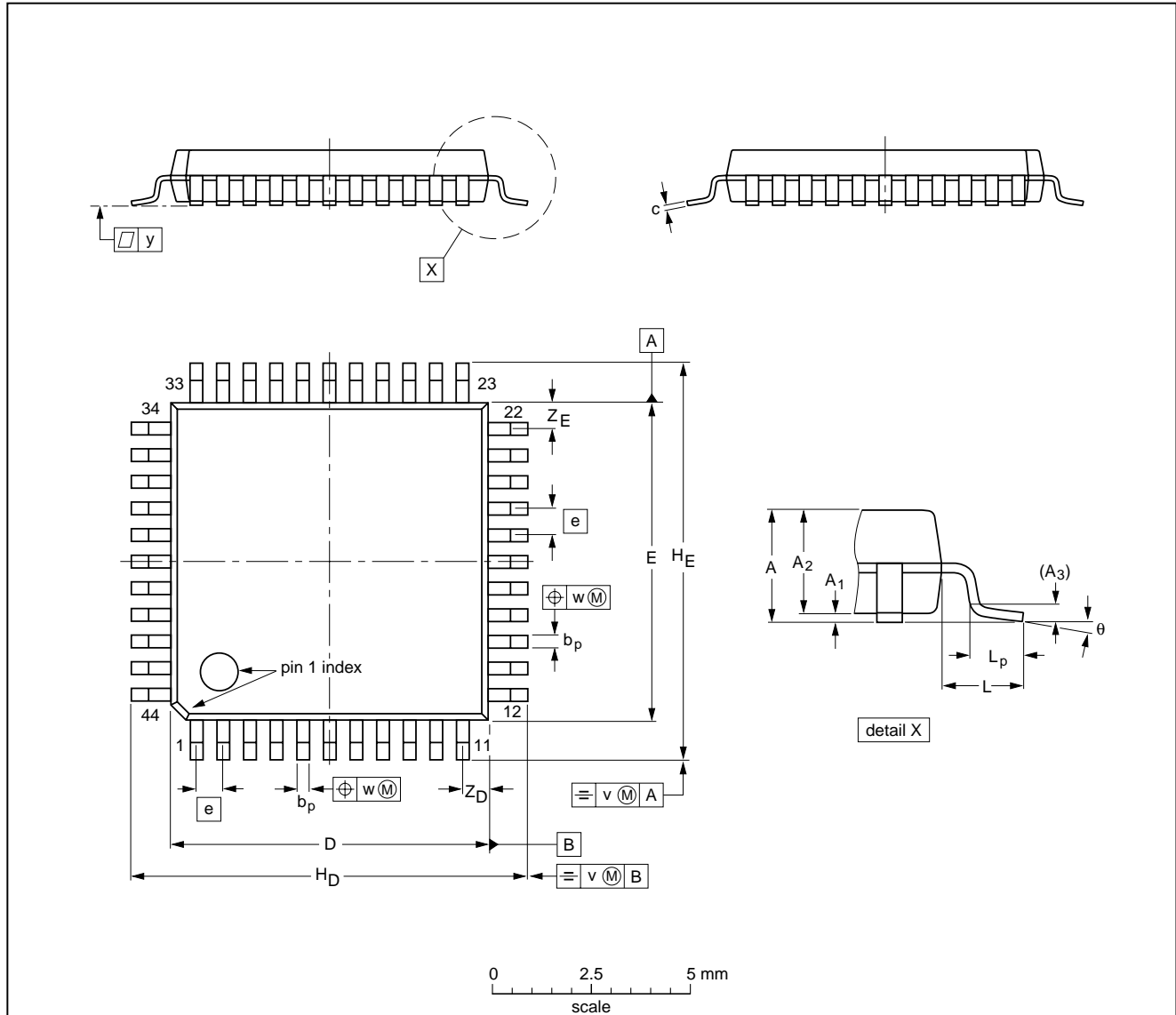

DIMENSIONS (mm are the original dimensions)

UNIT	A max.	A ₁	A ₂	A ₃	b _p	c	D ⁽¹⁾	E ⁽¹⁾	e	H _D	H _E	L	L _p	v	w	y	Z _D ⁽¹⁾	Z _E ⁽¹⁾	θ
mm	2.10	0.25 0.05	1.85 1.65	0.25	0.40 0.20	0.25 0.14	10.1 9.9	10.1 9.9	0.8	12.9 12.3	12.9 12.3	1.3	0.95 0.55	0.15	0.15	0.1	1.2 0.8	1.2 0.8	10° 0°

Note

1. Plastic or metal protrusions of 0.25 mm maximum per side are not included.

OUTLINE VERSION	REFERENCES				EUROPEAN PROJECTION	ISSUE DATE
	IEC	JEDEC	EIAJ			
SOT307-2						95-02-04 97-08-01

Audio processor with head amplifier for VHS hi-fi

TDA9605H

17 SOLDERING

17.1 Introduction to soldering surface mount packages

This text gives a very brief insight to a complex technology. A more in-depth account of soldering ICs can be found in our *"Data Handbook IC26; Integrated Circuit Packages"* (document order number 9398 652 90011).

There is no soldering method that is ideal for all surface mount IC packages. Wave soldering is not always suitable for surface mount ICs, or for printed-circuit boards with high population densities. In these situations reflow soldering is often used.

17.2 Reflow soldering

Reflow soldering requires solder paste (a suspension of fine solder particles, flux and binding agent) to be applied to the printed-circuit board by screen printing, stencilling or pressure-syringe dispensing before package placement.

Several methods exist for reflowing; for example, infrared/convection heating in a conveyor type oven. Throughput times (preheating, soldering and cooling) vary between 100 and 200 seconds depending on heating method.

Typical reflow peak temperatures range from 215 to 250 °C. The top-surface temperature of the packages should preferably be kept below 230 °C.

17.3 Wave soldering

Conventional single wave soldering is not recommended for surface mount devices (SMDs) or printed-circuit boards with a high component density, as solder bridging and non-wetting can present major problems.

To overcome these problems the double-wave soldering method was specifically developed.

If wave soldering is used the following conditions must be observed for optimal results:

- Use a double-wave soldering method comprising a turbulent wave with high upward pressure followed by a smooth laminar wave.
- For packages with leads on two sides and a pitch (e):
 - larger than or equal to 1.27 mm, the footprint longitudinal axis is **preferred** to be parallel to the transport direction of the printed-circuit board;
 - smaller than 1.27 mm, the footprint longitudinal axis **must** be parallel to the transport direction of the printed-circuit board.

The footprint must incorporate solder thieves at the downstream end.

- For packages with leads on four sides, the footprint must be placed at a 45° angle to the transport direction of the printed-circuit board. The footprint must incorporate solder thieves downstream and at the side corners.

During placement and before soldering, the package must be fixed with a droplet of adhesive. The adhesive can be applied by screen printing, pin transfer or syringe dispensing. The package can be soldered after the adhesive is cured.

Typical dwell time is 4 seconds at 250 °C.

A mildly-activated flux will eliminate the need for removal of corrosive residues in most applications.

17.4 Manual soldering

Fix the component by first soldering two diagonally-opposite end leads. Use a low voltage (24 V or less) soldering iron applied to the flat part of the lead. Contact time must be limited to 10 seconds at up to 300 °C.

When using a dedicated tool, all other leads can be soldered in one operation within 2 to 5 seconds between 270 and 320 °C.

Audio processor with head amplifier for VHS hi-fi

TDA9605H

17.5 Suitability of surface mount IC packages for wave and reflow soldering methods

PACKAGE	SOLDERING METHOD	
	WAVE	REFLOW ⁽¹⁾
BGA, SQFP	not suitable	suitable
HLQFP, HSQFP, HSOP, HTSSOP, SMS	not suitable ⁽²⁾	suitable
PLCC ⁽³⁾ , SO, SOJ	suitable	suitable
LQFP, QFP, TQFP	not recommended ⁽³⁾⁽⁴⁾	suitable
SSOP, TSSOP, VSO	not recommended ⁽⁵⁾	suitable

Notes

1. All surface mount (SMD) packages are moisture sensitive. Depending upon the moisture content, the maximum temperature (with respect to time) and body size of the package, there is a risk that internal or external package cracks may occur due to vaporization of the moisture in them (the so called popcorn effect). For details, refer to the Drypack information in the "Data Handbook IC26; Integrated Circuit Packages; Section: Packing Methods".
2. These packages are not suitable for wave soldering as a solder joint between the printed-circuit board and heatsink (at bottom version) can not be achieved, and as solder may stick to the heatsink (on top version).
3. If wave soldering is considered, then the package must be placed at a 45° angle to the solder wave direction. The package footprint must incorporate solder thieves downstream and at the side corners.
4. Wave soldering is only suitable for LQFP, TQFP and QFP packages with a pitch (e) equal to or larger than 0.8 mm; it is definitely not suitable for packages with a pitch (e) equal to or smaller than 0.65 mm.
5. Wave soldering is only suitable for SSOP and TSSOP packages with a pitch (e) equal to or larger than 0.65 mm; it is definitely not suitable for packages with a pitch (e) equal to or smaller than 0.5 mm.

Audio processor with head amplifier for VHS hi-fi

TDA9605H

18 DEFINITIONS

Data sheet status	
Objective specification	This data sheet contains target or goal specifications for product development.
Preliminary specification	This data sheet contains preliminary data; supplementary data may be published later.
Product specification	This data sheet contains final product specifications.
Limiting values	
Limiting values given are in accordance with the Absolute Maximum Rating System (IEC 134). Stress above one or more of the limiting values may cause permanent damage to the device. These are stress ratings only and operation of the device at these or at any other conditions above those given in the Characteristics sections of the specification is not implied. Exposure to limiting values for extended periods may affect device reliability.	
Application information	
Where application information is given, it is advisory and does not form part of the specification.	

19 LIFE SUPPORT APPLICATIONS

These products are not designed for use in life support appliances, devices, or systems where malfunction of these products can reasonably be expected to result in personal injury. Philips customers using or selling these products for use in such applications do so at their own risk and agree to fully indemnify Philips for any damages resulting from such improper use or sale.

20 PURCHASE OF PHILIPS I²C COMPONENTS

Purchase of Philips I²C components conveys a license under the Philips I²C patent to use the components in the I²C system provided the system conforms to the I²C specification defined by Philips. This specification can be ordered using the code 9398 393 40011.

Philips Semiconductors – a worldwide company

Argentina: see South America

Australia: 34 Waterloo Road, NORTH RYDE, NSW 2113,
Tel. +61 2 9805 4455, Fax. +61 2 9805 4466

Austria: Computerstr. 6, A-1101 WIEN, P.O. Box 213,
Tel. +43 1 60 101 1248, Fax. +43 1 60 101 1210

Belarus: Hotel Minsk Business Center, Bld. 3, r. 1211, Volodarski Str. 6,
220050 MINSK, Tel. +375 172 20 0733, Fax. +375 172 20 0773

Belgium: see The Netherlands

Brazil: see South America

Bulgaria: Philips Bulgaria Ltd., Energoproject, 15th floor,
51 James Bourchier Blvd., 1407 SOFIA,
Tel. +359 2 68 9211, Fax. +359 2 68 9102

Canada: PHILIPS SEMICONDUCTORS/COMPONENTS,
Tel. +1 800 234 7381, Fax. +1 800 943 0087

China/Hong Kong: 501 Hong Kong Industrial Technology Centre,
72 Tat Chee Avenue, Kowloon Tong, HONG KONG,
Tel. +852 2319 7888, Fax. +852 2319 7700

Colombia: see South America

Czech Republic: see Austria

Denmark: Sydhavnsgade 23, 1780 COPENHAGEN V,
Tel. +45 33 29 3333, Fax. +45 33 29 3905

Finland: Sinikalliontie 3, FIN-02630 ESPOO,
Tel. +358 9 615 800, Fax. +358 9 6158 0920

France: 51 Rue Carnot, BP317, 92156 SURESNES Cedex,
Tel. +33 1 4099 6161, Fax. +33 1 4099 6427

Germany: Hammerbrookstraße 69, D-20097 HAMBURG,
Tel. +49 40 2353 60, Fax. +49 40 2353 6300

Hungary: see Austria

India: Philips INDIA Ltd, Band Box Building, 2nd floor,
254-D, Dr. Annie Besant Road, Worli, MUMBAI 400 025,
Tel. +91 22 493 8541, Fax. +91 22 493 0966

Indonesia: PT Philips Development Corporation, Semiconductors Division,
Gedung Philips, Jl. Buncit Raya Kav.99-100, JAKARTA 12510,
Tel. +62 21 794 0040 ext. 2501, Fax. +62 21 794 0080

Ireland: Newstead, Clonskeagh, DUBLIN 14,
Tel. +353 1 7640 000, Fax. +353 1 7640 200

Israel: RAPAC Electronics, 7 Kehilat Saloniki St, PO Box 18053,
TEL AVIV 61180, Tel. +972 3 645 0444, Fax. +972 3 649 1007

Italy: PHILIPS SEMICONDUCTORS, Piazza IV Novembre 3,
20124 MILANO, Tel. +39 2 6752 2531, Fax. +39 2 6752 2557

Japan: Philips Bldg 13-37, Kohnan 2-chome, Minato-ku,
TOKYO 108-8507, Tel. +81 3 3740 5130, Fax. +81 3 3740 5077

Korea: Philips House, 260-199 Itaewon-dong, Yongsan-ku, SEOUL,
Tel. +82 2 709 1412, Fax. +82 2 709 1415

Malaysia: No. 76 Jalan Universiti, 46200 PETALING JAYA, SELANGOR,
Tel. +60 3 750 5214, Fax. +60 3 757 4880

Mexico: 5900 Gateway East, Suite 200, EL PASO, TEXAS 79905,
Tel. +9-5 800 234 7381, Fax +9-5 800 943 0087

Middle East: see Italy

Netherlands: Postbus 90050, 5600 PB EINDHOVEN, Bldg. VB,
Tel. +31 40 27 82785, Fax. +31 40 27 88399

New Zealand: 2 Wagener Place, C.P.O. Box 1041, AUCKLAND,
Tel. +64 9 849 4160, Fax. +64 9 849 7811

Norway: Box 1, Manglerud 0612, OSLO,
Tel. +47 22 74 8000, Fax. +47 22 74 8341

Pakistan: see Singapore

Philippines: Philips Semiconductors Philippines Inc.,
106 Valero St. Salcedo Village, P.O. Box 2108 MCC, MAKATI,
Metro MANILA, Tel. +63 2 816 6380, Fax. +63 2 817 3474

Poland: Ul. Lukiska 10, PL 04-123 WARSZAWA,
Tel. +48 22 612 2831, Fax. +48 22 612 2327

Portugal: see Spain

Romania: see Italy

Russia: Philips Russia, Ul. Usatcheva 35A, 119048 MOSCOW,
Tel. +7 095 755 6918, Fax. +7 095 755 6919

Singapore: Lorong 1, Toa Payoh, SINGAPORE 319762,
Tel. +65 350 2538, Fax. +65 251 6500

Slovakia: see Austria

Slovenia: see Italy

South Africa: S.A. PHILIPS Pty Ltd., 195-215 Main Road Martindale,
2092 JOHANNESBURG, P.O. Box 7430 Johannesburg 2000,
Tel. +27 11 470 5911, Fax. +27 11 470 5494

South America: Al. Vicente Pinzon, 173, 6th floor,
04547-130 SÃO PAULO, SP, Brazil,
Tel. +55 11 821 2333, Fax. +55 11 821 2382

Spain: Balmes 22, 08007 BARCELONA,
Tel. +34 93 301 6312, Fax. +34 93 301 4107

Sweden: Kottbygatan 7, Akalla, S-16485 STOCKHOLM,
Tel. +46 8 5985 2000, Fax. +46 8 5985 2745

Switzerland: Allmendstrasse 140, CH-8027 ZÜRICH,
Tel. +41 1 488 2741 Fax. +41 1 488 3263

Taiwan: Philips Semiconductors, 6F, No. 96, Chien Kuo N. Rd., Sec. 1,
TAIPEI, Taiwan Tel. +886 2 2134 2886, Fax. +886 2 2134 2874

Thailand: PHILIPS ELECTRONICS (THAILAND) Ltd.,
209/2 Sanpavuth-Bangna Road Prakanong, BANGKOK 10260,
Tel. +66 2 745 4090, Fax. +66 2 398 0793

Turkey: Talatpasa Cad. No. 5, 80640 GÜLTEPE/ISTANBUL,
Tel. +90 212 279 2770, Fax. +90 212 282 6707

Ukraine: PHILIPS UKRAINE, 4 Patrice Lumumba str., Building B, Floor 7,
252042 KIEV, Tel. +380 44 264 2776, Fax. +380 44 268 0461

United Kingdom: Philips Semiconductors Ltd., 276 Bath Road, Hayes,
MIDDLESEX UB3 5BX, Tel. +44 181 730 5000, Fax. +44 181 754 8421

United States: 811 East Arques Avenue, SUNNYVALE, CA 94088-3409,
Tel. +1 800 234 7381, Fax. +1 800 943 0087

Uruguay: see South America

Vietnam: see Singapore

Yugoslavia: PHILIPS, Trg N. Pasica 5/v, 11000 BEOGRAD,
Tel. +381 11 62 5344, Fax. +381 11 63 5777

For all other countries apply to: Philips Semiconductors,
International Marketing & Sales Communications, Building BE-p, P.O. Box 218,
5600 MD EINDHOVEN, The Netherlands, Fax. +31 40 27 24825

Internet: <http://www.semiconductors.philips.com>

© Philips Electronics N.V. 1999

SCA63

All rights are reserved. Reproduction in whole or in part is prohibited without the prior written consent of the copyright owner.

The information presented in this document does not form part of any quotation or contract, is believed to be accurate and reliable and may be changed without notice. No liability will be accepted by the publisher for any consequence of its use. Publication thereof does not convey nor imply any license under patent- or other industrial or intellectual property rights.

Printed in The Netherlands

545004/750/01/pp52

Date of release: 1999 Apr 14

Document order number: 9397 750 04687

Let's make things better.

Philips
Semiconductors



PHILIPS