

# Unipolar Driver ICs

# SLA7020M SLA7021M WITH MOSFETs

## ■ Ratings

Absolute maximum ratings	Motor supply Voltage	FET output breakdown voltage	Control voltage	TTL input voltage	Reference voltage	Output current	Power dissipation	Channel temperature	Storage temperature
	(V)	(V)	(V)	(V)	(V)	(A)	(W)	(°C)	(°C)
Type No.	V <sub>CC</sub>	V <sub>DS</sub>	V <sub>S</sub>	V <sub>IN</sub>	V <sub>REF</sub>	I <sub>O</sub>	P <sub>D</sub>	T <sub>ch</sub>	T <sub>stg</sub>
SLA7020M	46	100	32	7	2	1.5	4.5 (No Fin)	150	-40 to +150
SLA7021M						3			

## ■ Characteristics (1) DC Characteristics

Electrical characteristics	Control current			Control voltage			FET turn-on voltage			FET drain leak current			TTL input current			TTL input current			TTL input voltage (OUT)			TTL input voltage			TTL input voltage (OUT)			TTL input voltage					
	(mA)			(V)			(V)			(mA)			(μA)			(mA)			(V)			(V)			(V)			(V)					
	V <sub>S</sub> = 30V						(7020M) I <sub>D</sub> = 1A, V <sub>S</sub> = 14V (7021M) I <sub>D</sub> = 3A, V <sub>S</sub> = 14V			V <sub>DSS</sub> = 100V V <sub>S</sub> = 30V			V <sub>IH</sub> = 2.4V V <sub>S</sub> = 30V			V <sub>IL</sub> = 0.4V V <sub>S</sub> = 30V			I <sub>D</sub> = 1A			V <sub>DSS</sub> = 100V			V <sub>DSS</sub> = 100V			I <sub>D</sub> = 1A					
Type No.	I <sub>S</sub>			V <sub>S</sub>			V <sub>DS</sub>			I <sub>DSS</sub>			I <sub>IH</sub>			I <sub>IL</sub>			V <sub>IH</sub>			V <sub>IL</sub>			V <sub>IH</sub>			V <sub>IL</sub>					
	min	typ	max	min	typ	max	min	typ	max	min	typ	max	min	typ	max	min	typ	max	min	typ	max	min	typ	max	min	typ	max	min	typ	max	min	typ	max
SLA7020M									0.6			4			40			-0.8	2.0					0.8	2.0								0.8
SLA7021M	5.5	10	15	10	19	30			0.85																								

## (2) AC Characteristics

Electrical characteristics	FET diode forward voltage			Switching time											
	(V)			(μs)											
	(7020M) I <sub>SD</sub> = 1A (7021M) I <sub>SD</sub> = 3A			V <sub>S</sub> = 24V I <sub>D</sub> = 1A											
Type No.	V <sub>SD</sub>			T <sub>r</sub>			T <sub>stg</sub>			T <sub>f</sub>					
	min	typ	max	min	typ	max	min	typ	max	min	typ	max			
SLA7020M			1.1												0.1
SLA7021M			2.3		0.5			0.7							

# SLA7020M and SLA7021M

## ■ Block diagram

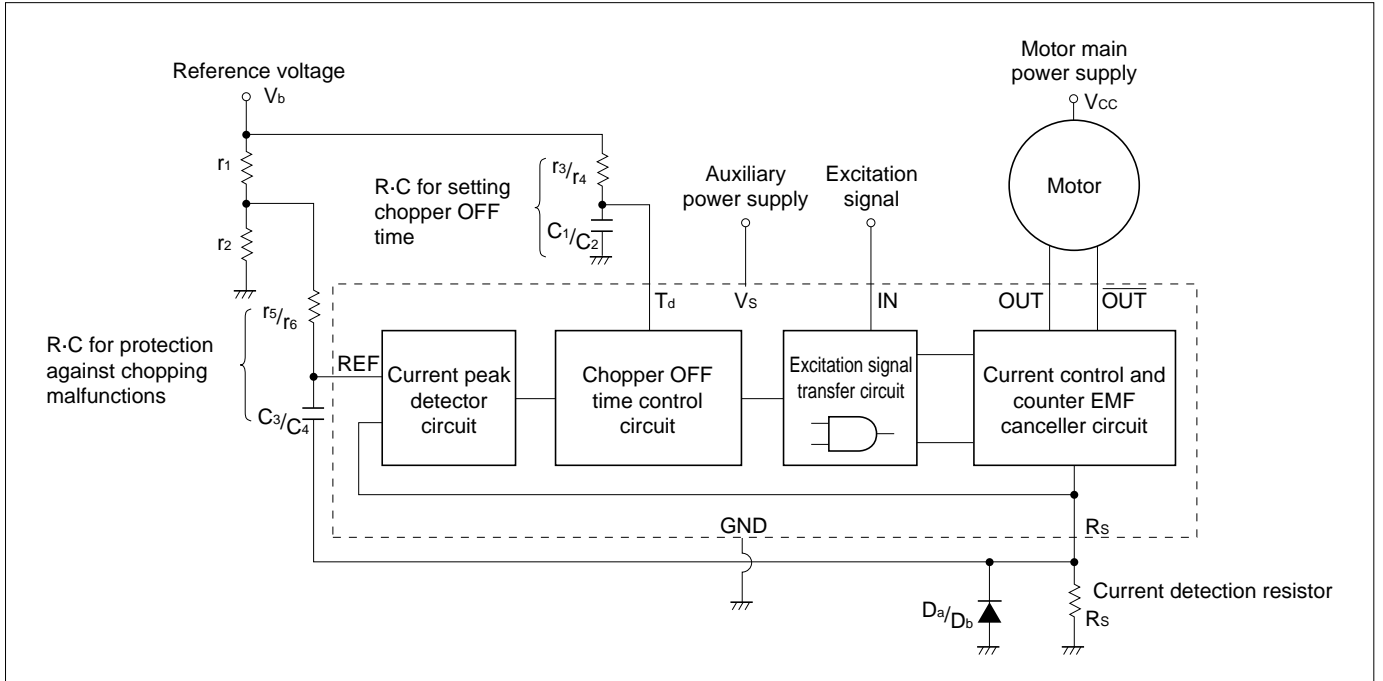

## ■ Internal circuit diagram (enclosed with chain line)

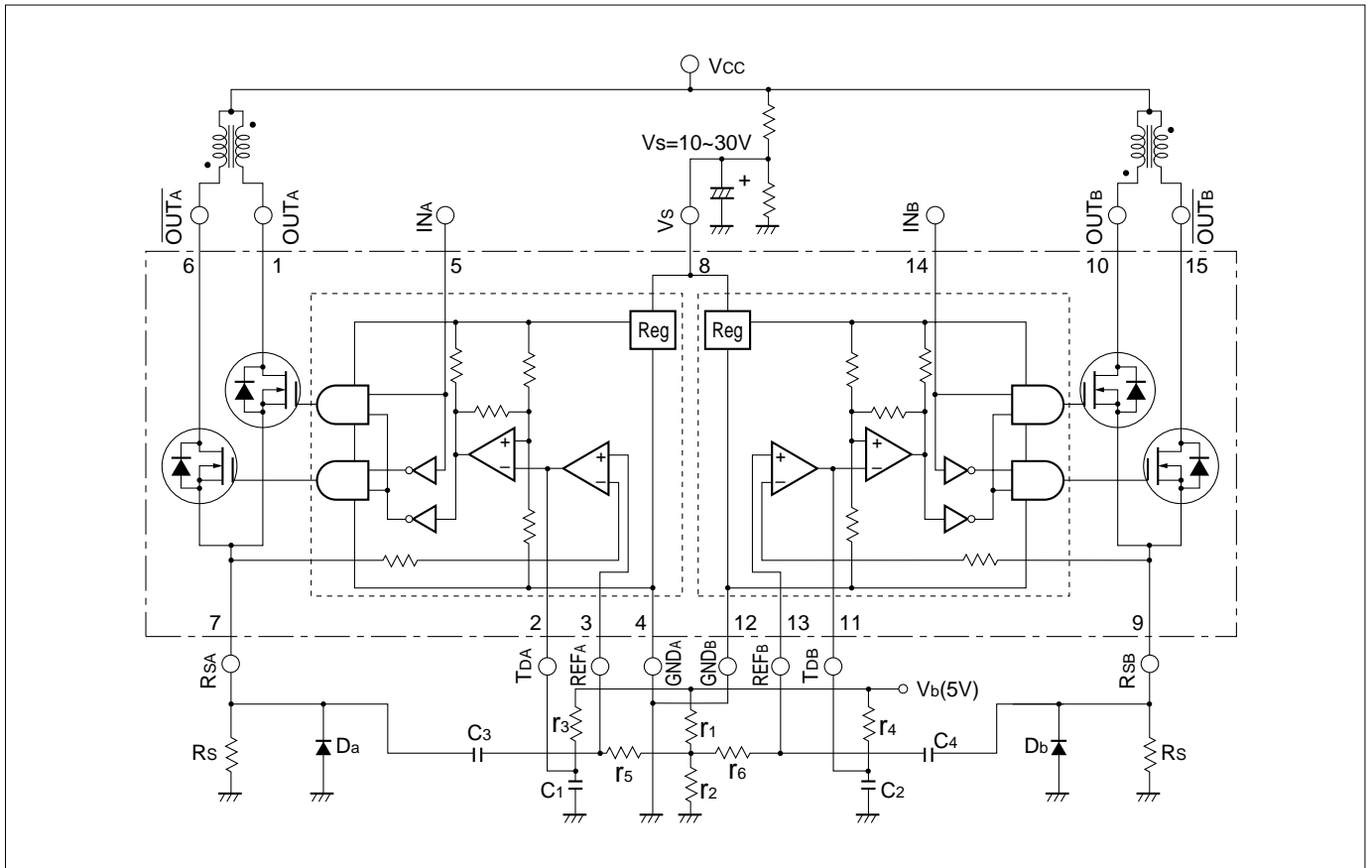

# SLA7020M and SLA7021M

## ■ Diagram of standard external circuit (Recommended circuit constants)

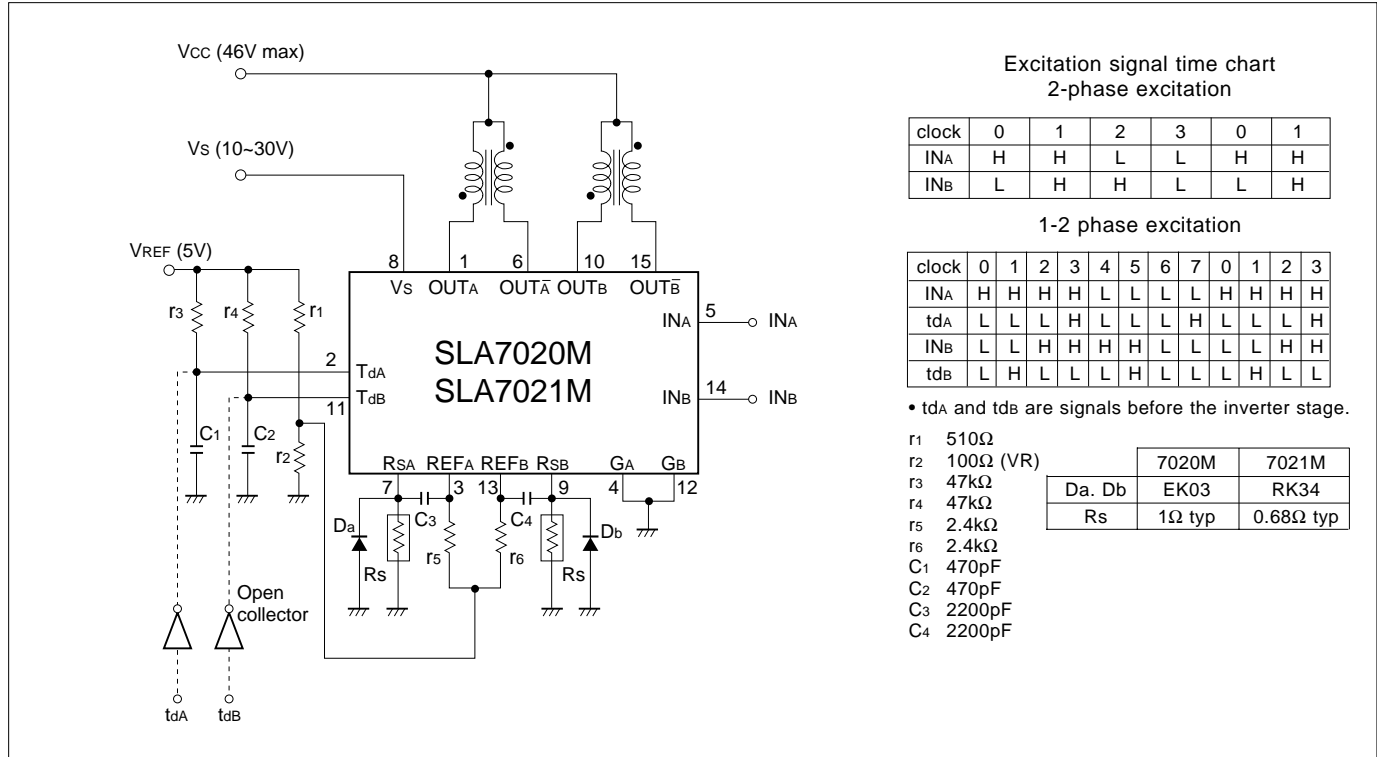

## ■ External dimensions

(Unit: mm)

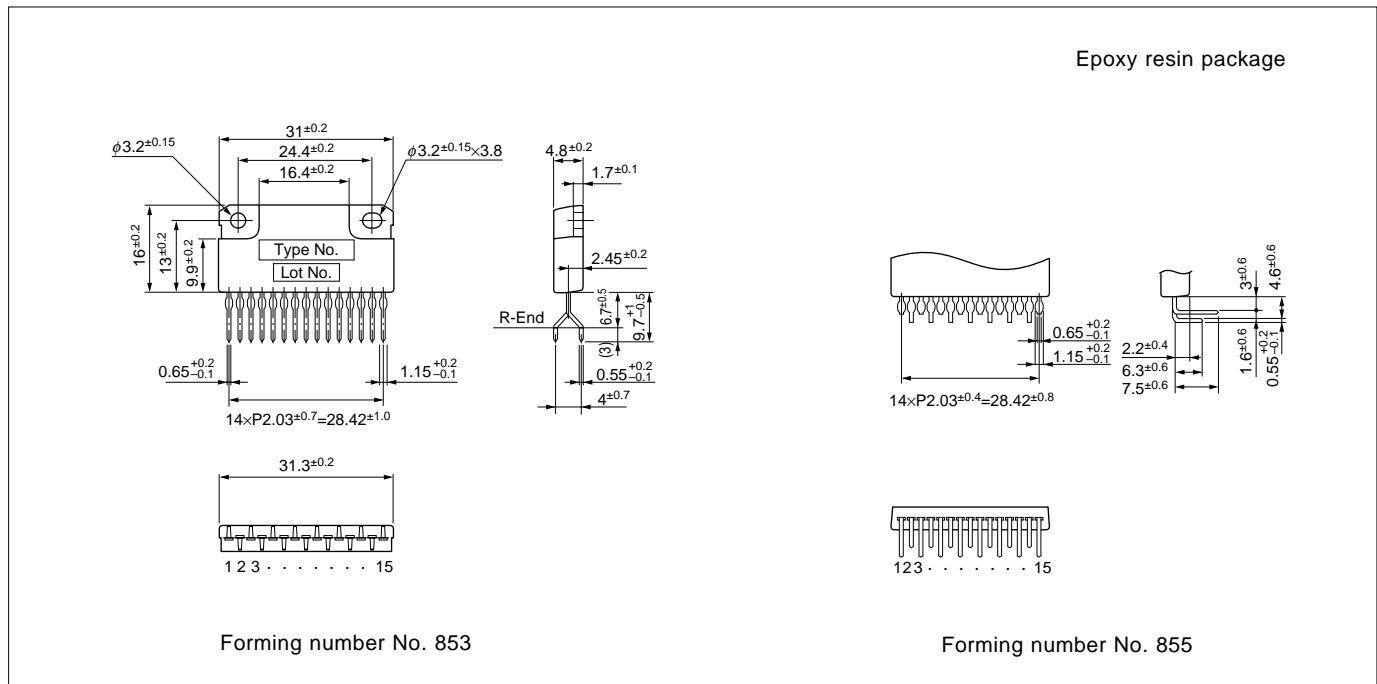

## Application Note

### ■ Determining the output current

Fig. 1 shows the waveform of the output current (motor coil current). The method of determining the peak value ( $I_o$ ) of the output current based on this waveform is shown below.

<Parameters for determining the output current  $I_o$ >

- $V_b$  : Reference supply voltage
- $r_1, r_2$  : Voltage-divider resistors for the reference supply voltage
- $R_s$  : Current detection resistor

(1) Normal rotation mode

$I_o$  is determined as follows when current flows at the maximum level during motor rotation. See Fig. 2, 3 and 4.

$$I_o \doteq \frac{r_2}{r_1+r_2} \cdot \frac{V_b}{R_s} \dots\dots\dots \textcircled{1}$$

(2) Power down mode

The circuits in Fig. 5, 6 and 7 ( $r_x$  and  $T_r$ ) are added in order to decrease the coil current.  $I_o$  is then determined as follows.

$$I_{OPD} \doteq \frac{1}{1 + \frac{r_1(r_2+r_x)}{r_2 \cdot r_x}} \cdot \frac{V_b}{R_s} \dots\dots\dots \textcircled{2}$$

To determine  $r_x$ , equation ② can be modified to obtain equation ③.

$$r_x \doteq \frac{1}{\frac{1}{r_1} \left( \frac{V_b}{R_s \cdot I_{OPD}} - 1 \right) - \frac{1}{r_2}} \dots\dots\dots \textcircled{3}$$

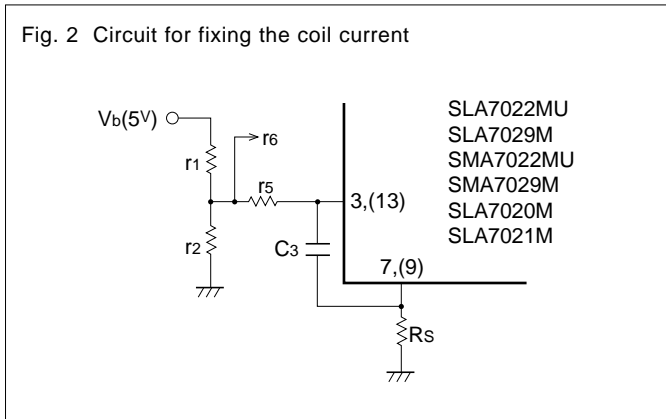
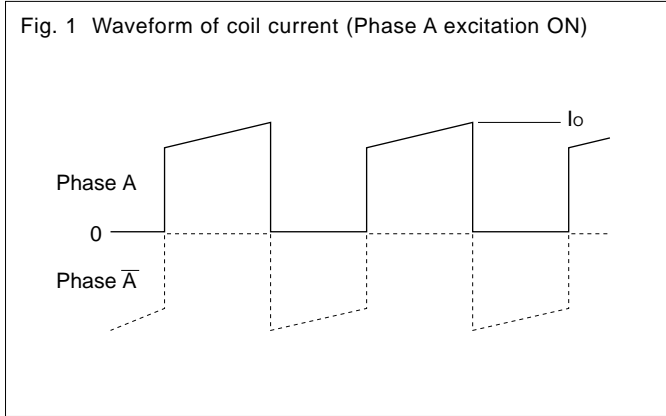
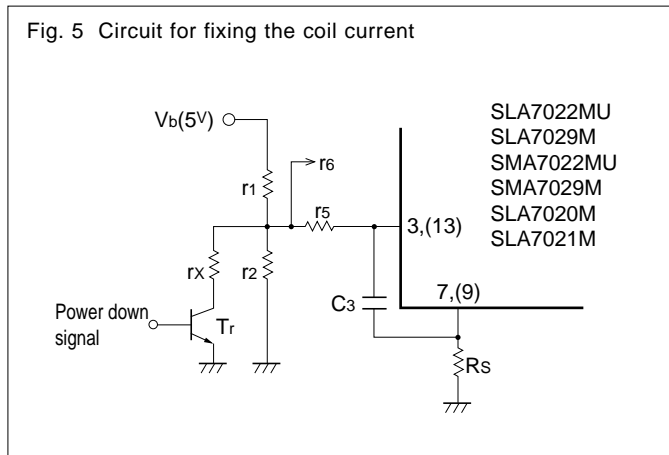
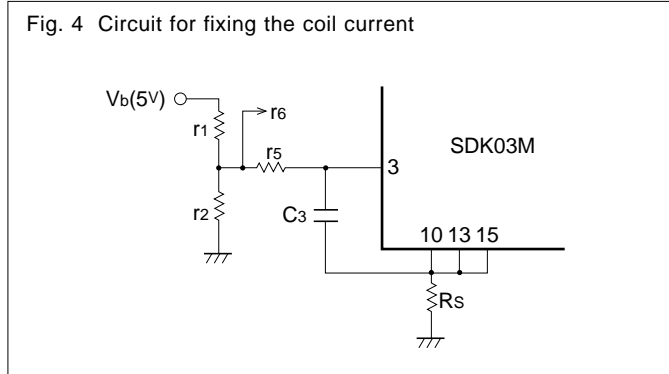
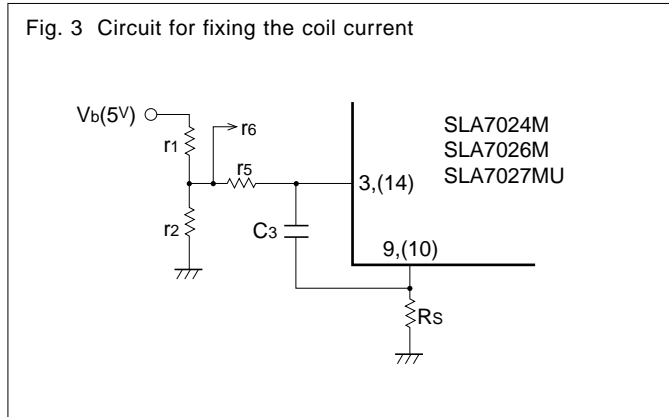

# SLA7024M, SLA7026M, SLA7027MU, SLA7022MU, SLA7029M, SMA7022MU, SMA7029M, SLA7020M, SLA7021M and SDK03M

## Application Note

Fig. 6 Circuit for fixing the coil current

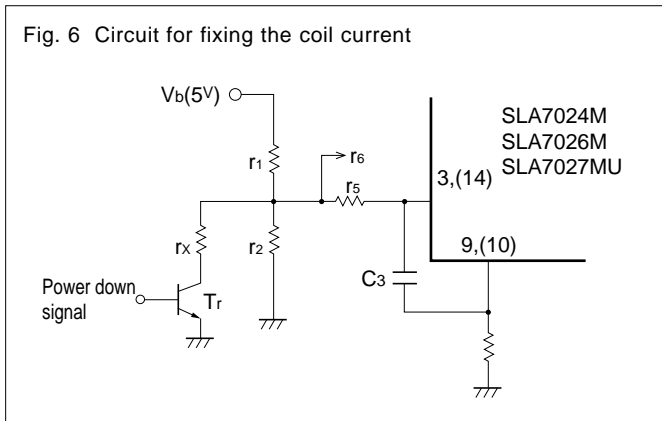

Fig. 7 Circuit for fixing the coil current

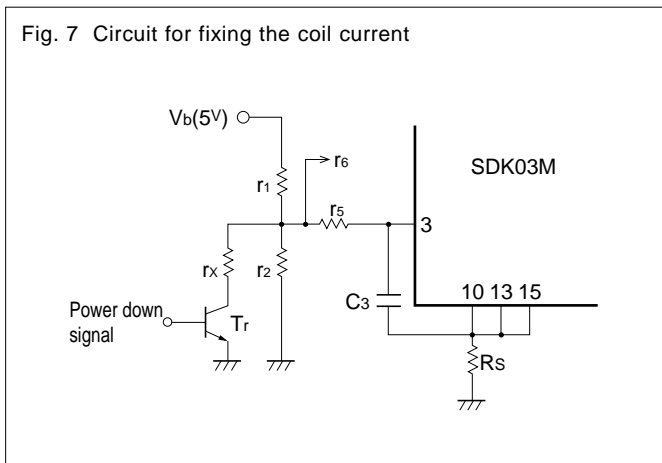

Fig. 8 and 9 show the graphs of equations ① and ②, respectively.

Fig. 8 Output current  $I_o$  vs. Current detection resistor  $R_s$

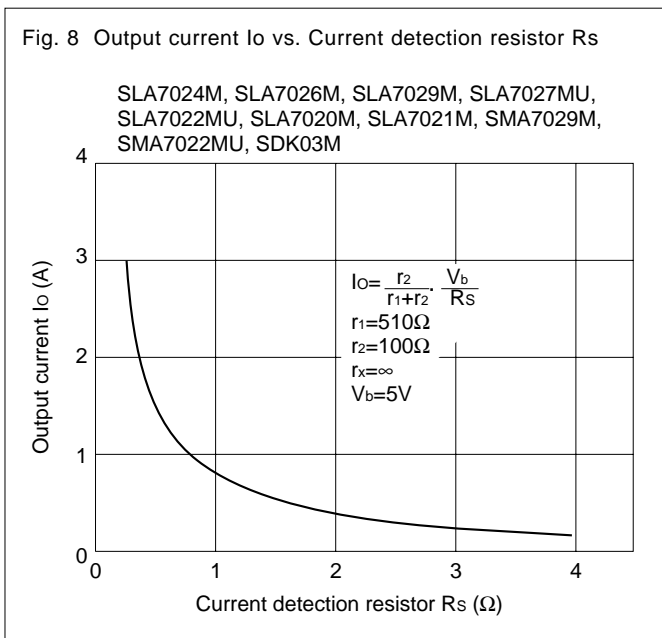
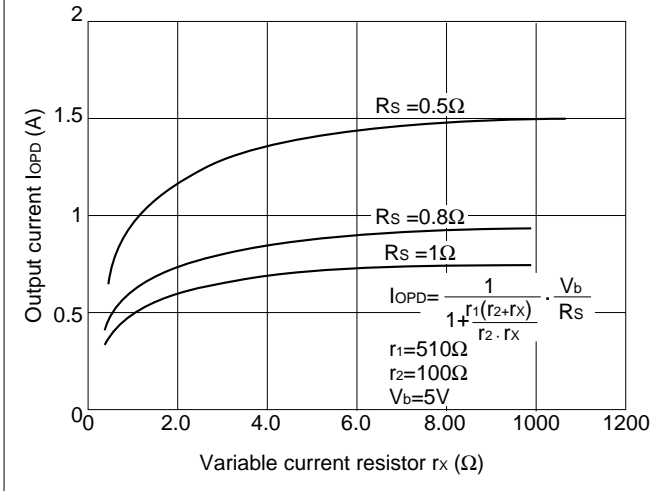

Fig. 9 Output current  $I_{OPD}$  vs. Variable current resistor  $r_x$

SLA7024M, SLA7026M, SLA7029M, SLA7027MU, SLA7022MU, SLA7020M, SLA7021M, SMA7029M, SMA7022MU, SDK03M



### NOTE:

Ringing noise is produced in the current detection resistor  $R_s$  when the MOSFET is switched ON and OFF through chopping. This noise is also generated in feedback signals from  $R_s$  which may therefore causes the comparator to malfunction.

To prevent chopping malfunctions,  $r_5(r_6)$  and  $C_3(C_4)$  are added in order to act as noise filter.

However, when the values of these constants are increased, the response from  $R_s$  to the comparator becomes slow. Hence, the value of the output current  $I_o$  is higher to some extent than the computed value.

# SLA7024M, SLA7026M, SLA7027MU, SLA7022MU, SLA7029M, SMA7022MU, SMA7029M, SLA7020M, SLA7021M and SDK03M

## Application Note

### Determining the chopper frequency

Determining  $T_{OFF}$ : SLA7000M series, SMA7000M series and SDK03M are self-excited choppers. The chopping OFF time  $T_{OFF}$  is fixed by  $r_3/C_1$  and  $r_4/C_2$  connected to terminal Td.

$T_{OFF}$  can be computed through the following formula:

$$T_{OFF} \doteq -r_3 \cdot C_1 \ln \left(1 - \frac{2}{V_b}\right) = -r_4 \cdot C_2 \ln \left(1 - \frac{2}{V_b}\right)$$

The circuit constants and the  $T_{OFF}$  value shown below are recommended.

$$\begin{aligned} T_{OFF} &= 12 \mu s \\ r_3 &= 47 \text{ K}\Omega \\ C_1 &= 500 \text{ pF} \\ V_b &= 5 \text{ V} \end{aligned}$$

Fig. 10 Chopper frequency vs. Motor coil resistance

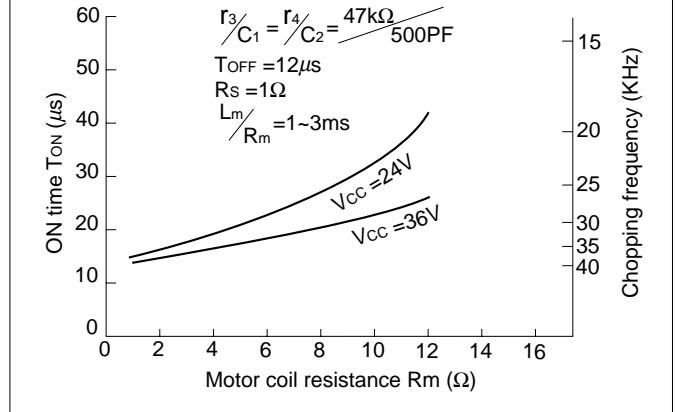

### Thermal design

An outline on the method of computing heat dissipation is shown below.

- Obtain the  $P_H$  that corresponds to the motor coil current  $I_o$  from Fig. 11 "Heat dissipation per phase  $P_H$  vs. Output current  $I_o$ ".
- The power dissipation  $P_{diss}$  is obtained through the following formula.
  - SLA7000M and SMA7000M series
    - 2-phase excitation :  $P_{diss} \doteq 2P_H + 0.015 \times V_s$  (W)
    - 1-2 phase excitation :  $P_{diss} \doteq \frac{3}{2}P_H + 0.015 \times V_s$  (W)
  - SDK03M
    - 2-phase excitation :  $P_{diss} \doteq P_H + 0.015 \times V_s$  (W)
    - 1-2 phase excitation :  $P_{diss} \doteq \frac{3}{4}P_H + 0.015 \times V_s$  (W)
- Obtain the temperature rise that corresponds to the computed  $P_{diss}$  from Fig. 12 "Temperature rise curve."

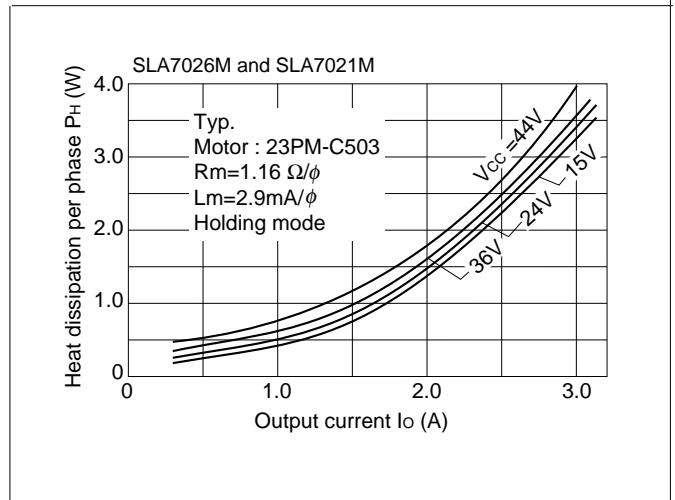
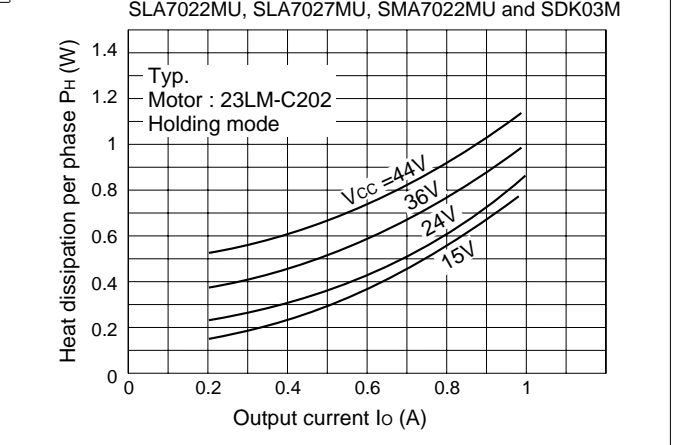
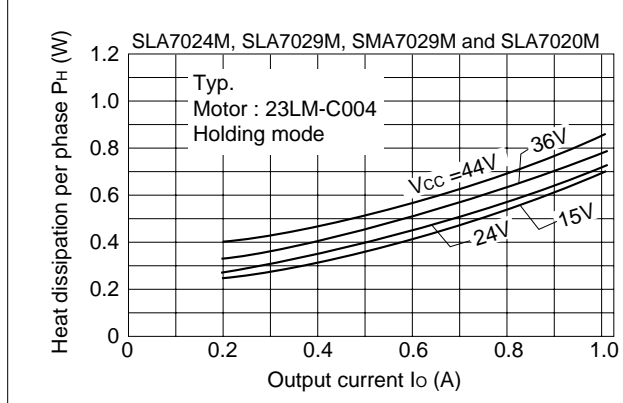

Fig. 11 Heat dissipation per phase  $P_H$  vs. Output current  $I_o$



**SLA7024M, SLA7026M, SLA7027MU, SLA7022MU, SLA7029M, SMA7022MU, SMA7029M, SLA7020M, SLA7021M and SDK03M**

**Application Note**

Fig. 12 Temperature rise curve

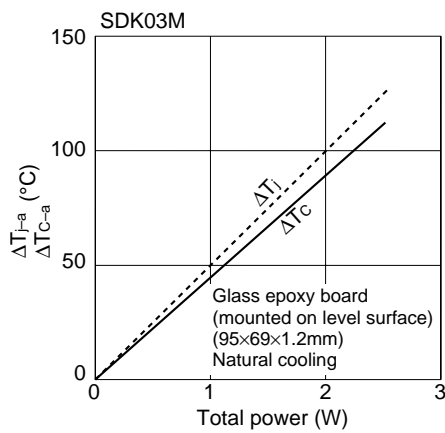
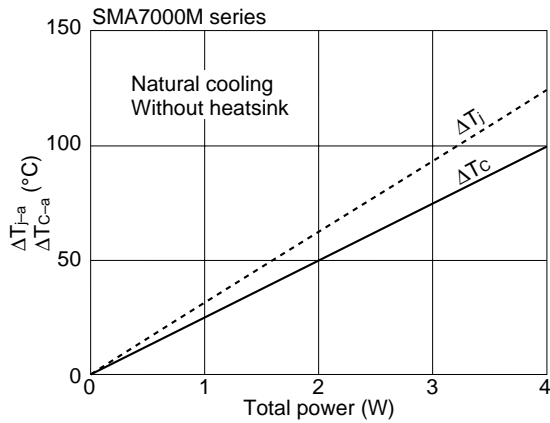
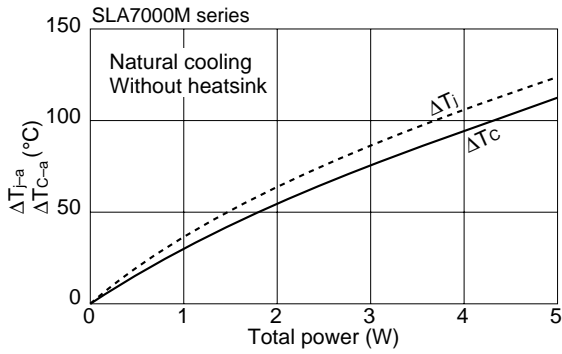

Comparison of losses

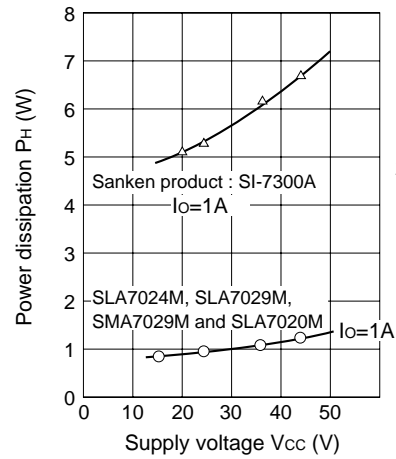

Motor : 23LM-C202  
 $I_o$  : Output current  
2-phase excitation,  
holding mode

# SLA7024M, SLA7026M, SLA7027MU, SLA7022MU, SLA7029M, SMA7022MU, SMA7029M, SLA7020M, SLA7021M and SDK03M

## Application Note

Heat dissipation characteristics

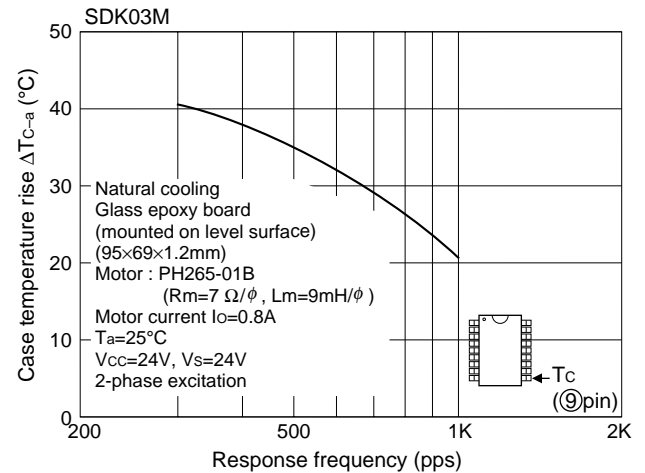
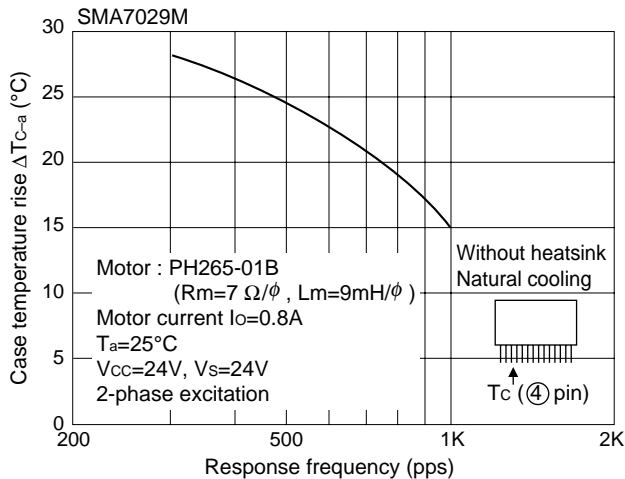
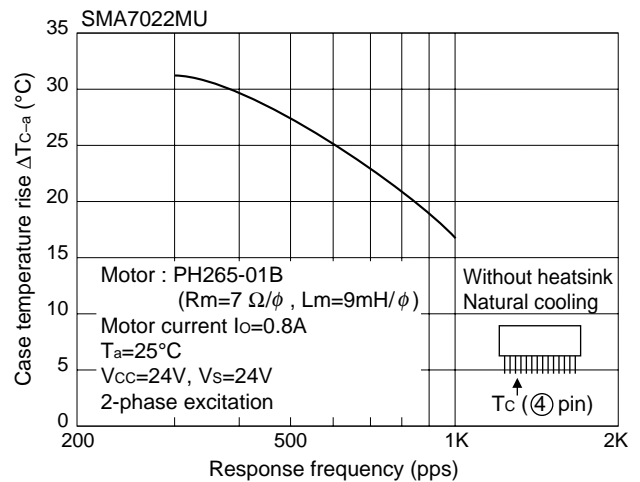
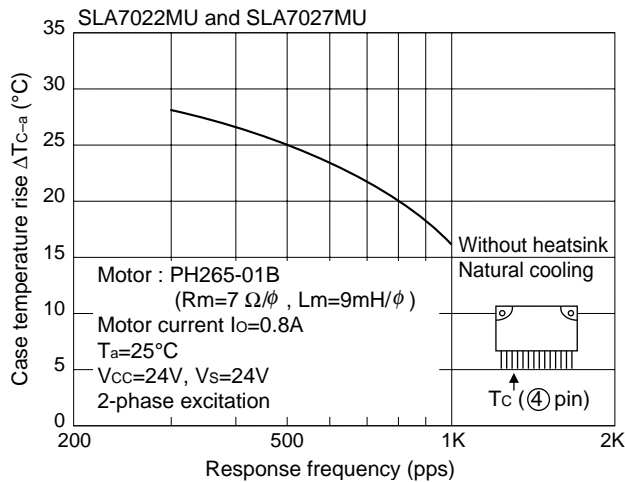
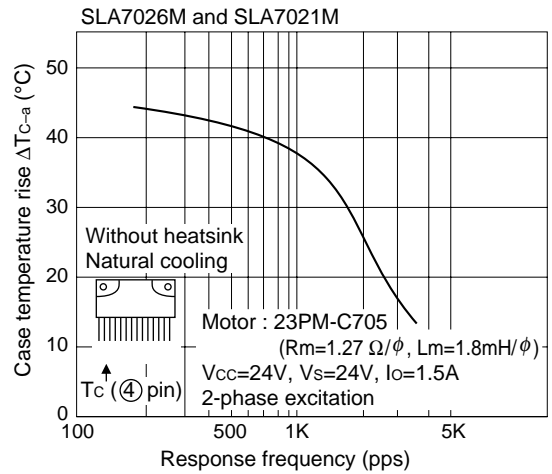
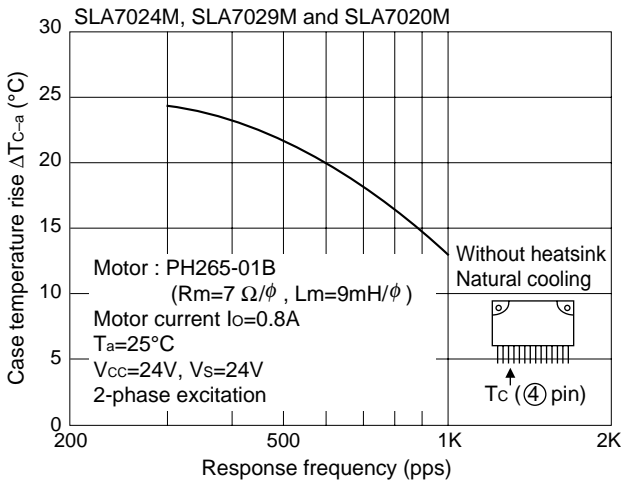



# SLA7024M, SLA7026M, SLA7027MU, SLA7022MU, SLA7029M, SMA7022MU, SMA7029M, SLA7020M, SLA7021M and SDK03M

## Application Note

Supply voltage  $V_{cc}$  vs. Supply current  $I_{cc}$

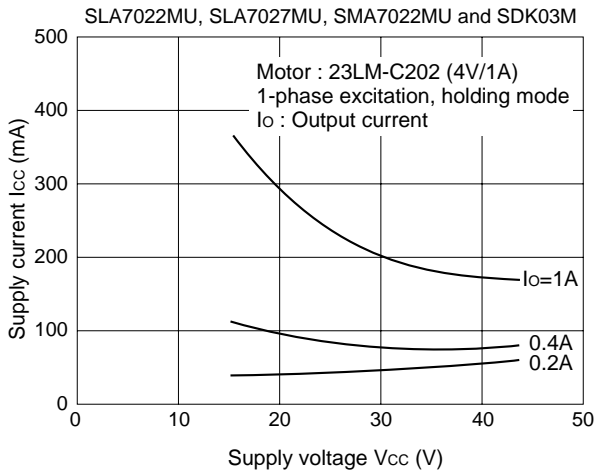
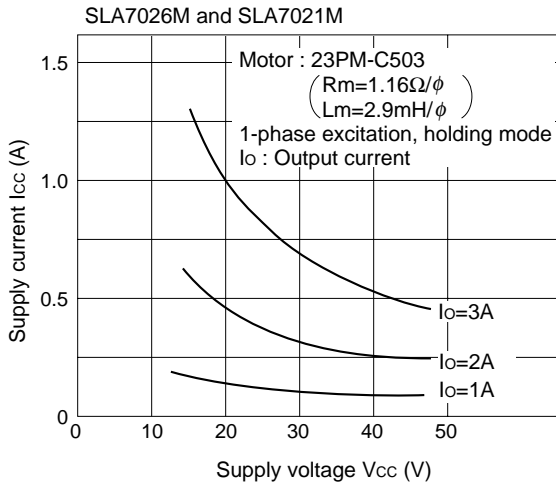
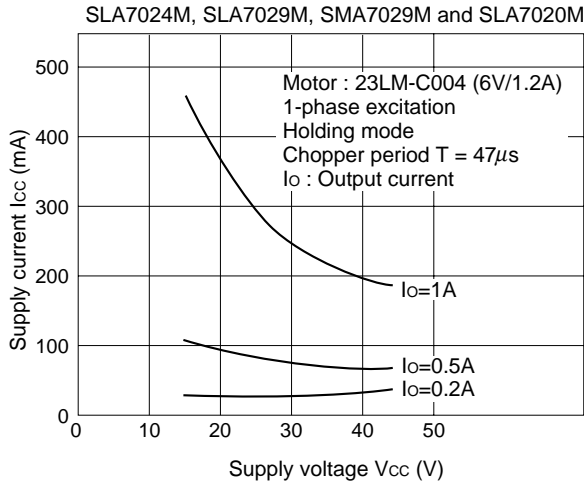

Torque characteristics

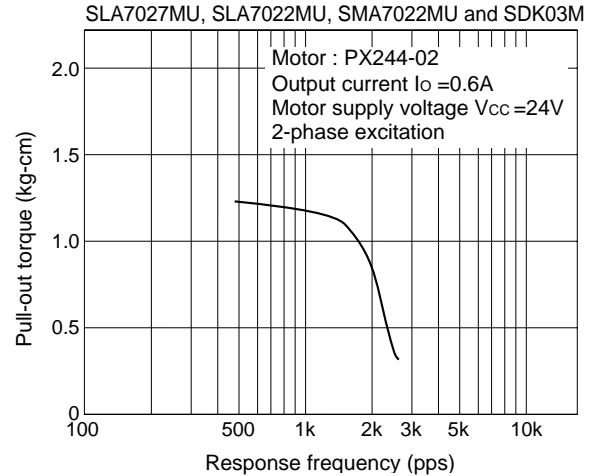
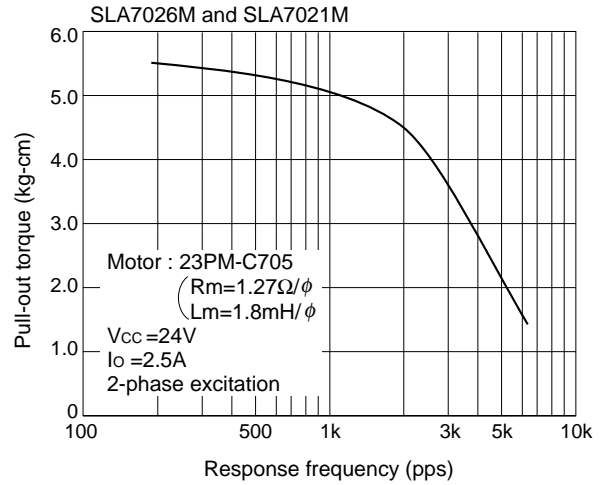
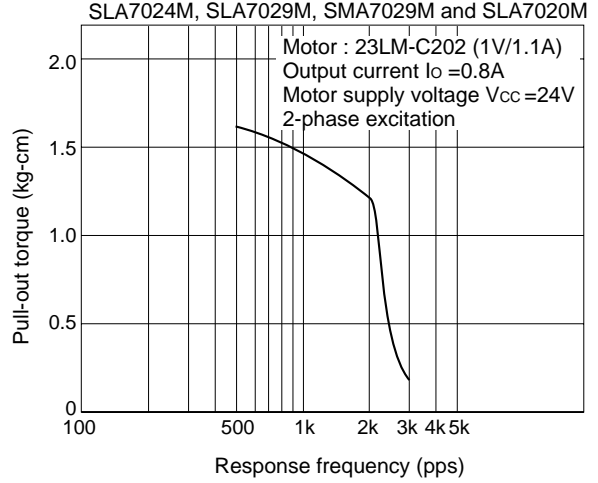

# SLA7024M, SLA7026M, SLA7027MU, SLA7022MU, SLA7029M, SMA7022MU, SMA7029M, SLA7020M, SLA7021M and SDK03M

## Application Note

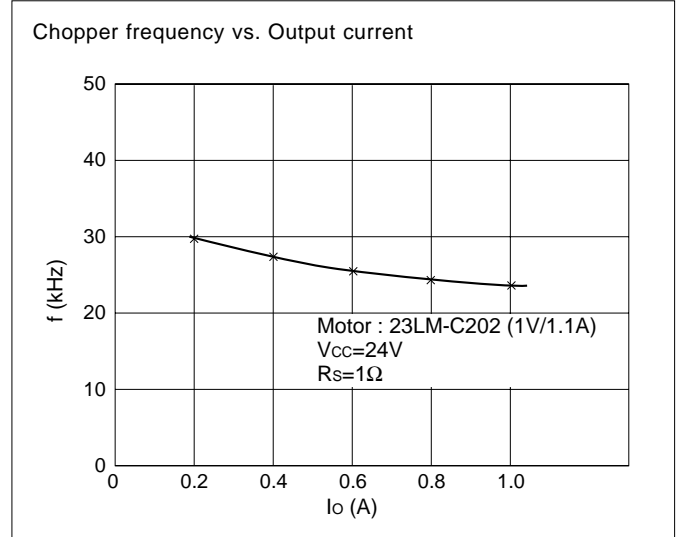
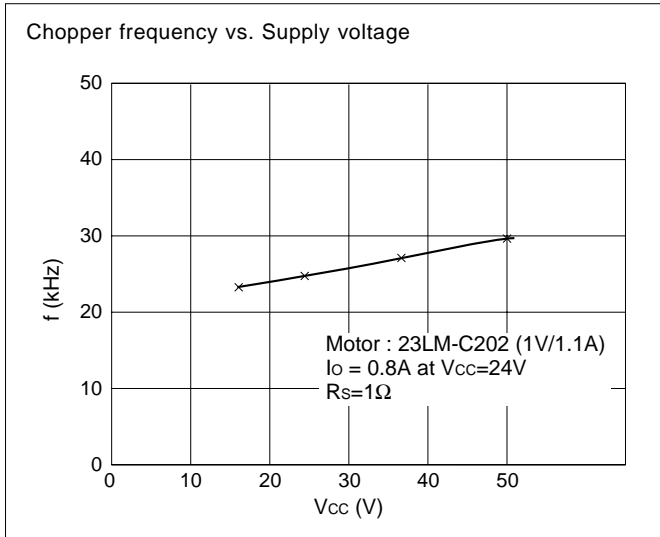

### NOTE

Either active high or active low excitation input signals can be used for SLA7024M, SLA7026M, SLA7027MU and SDK03M. However, take note of the output that corresponds to a specified input as shown in the table below.

- SLA7024M, SLA7026M and SLA7027MU

#### Active High

Input	Output
IN <sub>A</sub> (6 pin)	OUT <sub>A</sub> (1 pin)
IN <sub>A</sub> (5 pin)	OUT <sub>A</sub> (8 pin)
IN <sub>B</sub> (17 pin)	OUT <sub>B</sub> (11 pin)
IN <sub>B</sub> (16 pin)	OUT <sub>B</sub> (18 pin)

#### Active Low

Input	Output
IN <sub>A</sub> (6 pin)	OUT <sub>A</sub> (8 pin)
IN <sub>A</sub> (5 pin)	OUT <sub>A</sub> (1 pin)
IN <sub>B</sub> (17 pin)	OUT <sub>B</sub> (18 pin)
IN <sub>B</sub> (16 pin)	OUT <sub>B</sub> (11 pin)

- SDK03M

#### Active High

Input	Output
IN <sub>1</sub> (6 pin)	OUT <sub>1</sub> (1, 16 pin)
IN <sub>2</sub> (5 pin)	OUT <sub>2</sub> (8, 9 pin)

#### Active Low

Input	Output
IN <sub>1</sub> (6 pin)	OUT <sub>1</sub> (8, 9 pin)
IN <sub>2</sub> (5 pin)	OUT <sub>2</sub> (1, 16 pin)