

10 + 10W STEREO AMPLIFIER WITH MUTE/ST-BY

PRODUCT PREVIEW

- WIDE SUPPLY VOLTAGE RANGE (UP TO $\pm 22V$ ABS MAX.)
- SPLIT SUPPLY
- HIGH OUTPUT POWER:
10 + 10W @ THD = 10%, $R_L = 8\Omega$, $V_S = \pm 14V$
- NO POP AT TURN-ON/OFF
- MUTE (POP FREE)
- STAND-BY FEATURE (LOW I_Q)
- FEW EXTERNAL COMPONENTS
- SHORT CIRCUIT PROTECTION
- THERMAL OVERLOAD PROTECTION

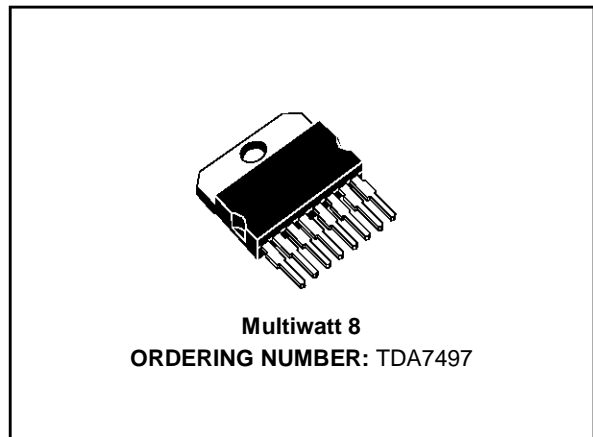

DESCRIPTION

The TDA7497 is class AB dual Audio power amplifier assembled in the Multiwatt package, spe-

cially designed for high quality sound application as Hi-Fi music centers and stereo TV sets.

Figure 1: Typical Application Circuit

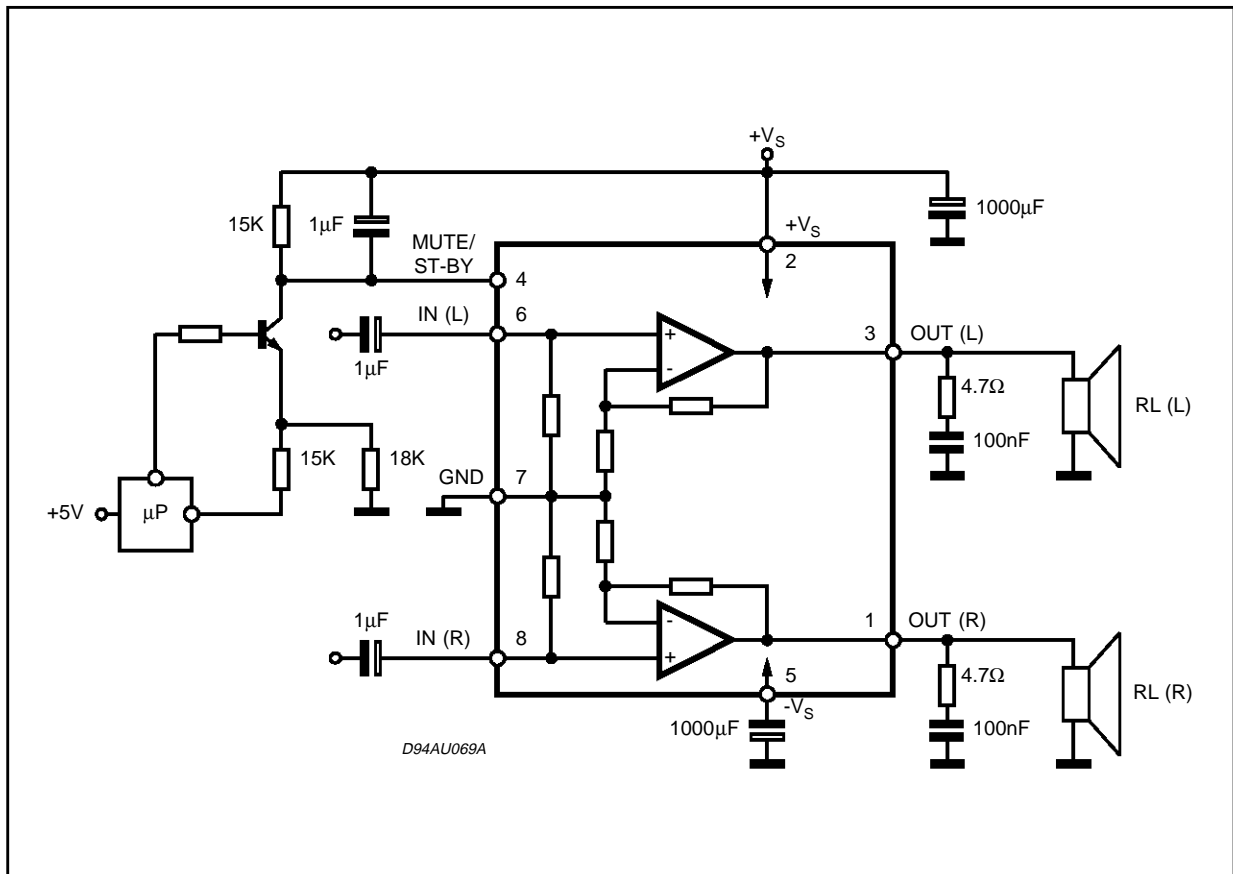

ABSOLUTE MAXIMUM RATINGS

Symbol	Parameter	Value	Unit
V_S	DC Supply Voltage	± 22	V
I_O	Output Peak Current (internally limited)	3	A
P_{tot}	Power Dissipation $T_{case} = 70^\circ\text{C}$	12	W
T_{stg}, T_j	Storage and Junction Temperature	-40 to +150	$^\circ\text{C}$

PIN CONNECTION (Top view)

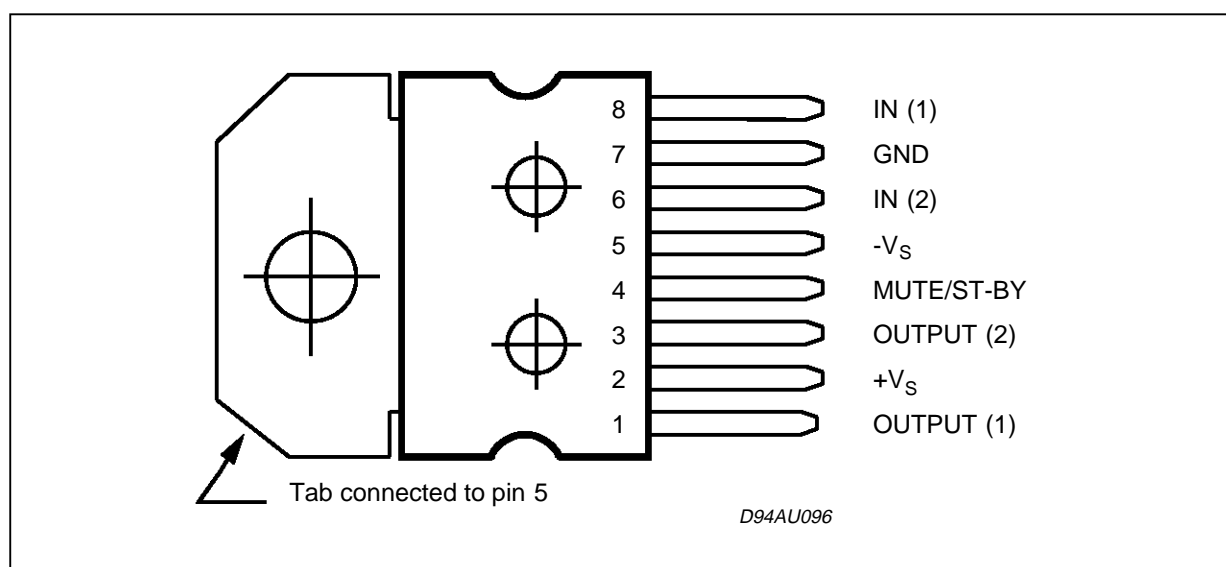

THERMAL DATA

Symbol	Description	Value	Unit
$R_{th\ j-case}$	Thermal Resistance Junction-case	Max 2	$^\circ\text{C/W}$

ELECTRICAL CHARACTERISTICS (Refer to the test circuit, $V_S \pm 14V$; $R_L = 8\Omega$; $R_S = 50\Omega$; $f = 1KHz$; $T_{amb} = 25^\circ C$, unless otherwise specified.)

Symbol	Parameter	Test Condition	Min.	Typ.	Max.	Unit
V_S	Supply Range		± 5		± 20	V
I_q	Total Quiescent Current			80		mA
P_O	Output Power	$d = 10\%$ $d = 1\%$		10 7.5		W W
d	Total Harmonic Distortion	$P_O = 1W$ $P_O = 0.1$ to $5W$ $f = 0.1$ to $15KHz$		0.02	0.5	% %
C_T	Cross Talk	$f = 1KHz$ $f = 10KHz$		70 60		dB dB
SR	Slew Rate			10		V/ μs
G_V	Closed Loop Voltage Gain		29	30	31	dB
ΔG_V	Voltage Gain Matching			0.2		dB
e_N	Total Input Noise	A Curve $f = 20Hz$ to $22KHz$		2.5 3.5	8	μV μV
R_i	Input Resistance		15	20		K Ω
SVR	Supply Voltage Rejection (each channel)	$f_r = 100Hz$; $V_{ripple} = 0.5V_{RMS}$		60		dB
T_j	Thermal Shut-down Junction Temperature			145		$^\circ C$
MUTE FUNCTION [ref: +Vs]						
$V_{T_{MUTE}}$	Mute / Play Threshold		-7	-6	-5	V
A_M	Mute Attenuation		60	90		dB
STAND-BY FUNCTION [ref: +Vs]						
$V_{T_{ST-BY}}$	Stand-by / Mute Threshold		-3.5	-2.5	-1.5	V
A_{ST-BY}	Stand-by Attenuation			110		dB
$I_{q_{ST-BY}}$	Quiescent Current @ Stand-by			3		mA

Note :

(*) **FULL POWER** up to. $V_S = \pm 22.5V$ with $R_L = 8\Omega$ and $V_S = \pm 16V$ with $R_L = 4\Omega$

MUSIC POWER is the maximal power which the amplifier is capable of producing across the rated load resistance (regardless of non linearity) 1 sec after the application of a sinusoidal input signal of frequency 1KHz.

APPLICATIONS SUGGESTION

(Demo Board Schematic)

The recommended values of the external compo-

nents are those shown on the demo board schematic. Different values can be used: the following table can help the designer.

COMPONENTS	RECOMMENDED VALUE	PURPOSE	LARGER THAN RECOMMENDED VALUE	SMALLER THAN RECOMMENDED VALUE
R1	10K Ω	Mute Circuit	Increase of D_z Biasing Current	
R2	15K Ω	Mute Circuit	$V_{pin \# 4}$ Shifted Downward	$V_{pin \# 4}$ Shifted Upward
R3	18K Ω	Mute Circuit	$V_{pin \# 4}$ Shifted Upward	$V_{pin \# 4}$ Shifted Downward
R4	15K Ω	Mute Circuit	$V_{pin \# 4}$ Shifted Upward	$V_{pin \# 4}$ Shifted Downward
R5, R6	4.7 Ω	Frequency Stability	Danger of Oscillations	Danger of Oscillations
C1, C2	1 μF	Input DC Decoupling		Higher Low Frequency Cutoff
C3	1 μF	St-By/Mute Time Constant	Larger On/Off Time	Smaller On/Off Time
C4, C6	1000 μF	Supply Voltage Bypass		Danger of Oscillations
C5, C7	0.1 μF	Supply Voltage Bypass		Danger of Oscillations
C8, C9	0.1 μF	Frequency Stability		
D_z	5.1V	Mute Circuit		

Figure 2: Application circuit

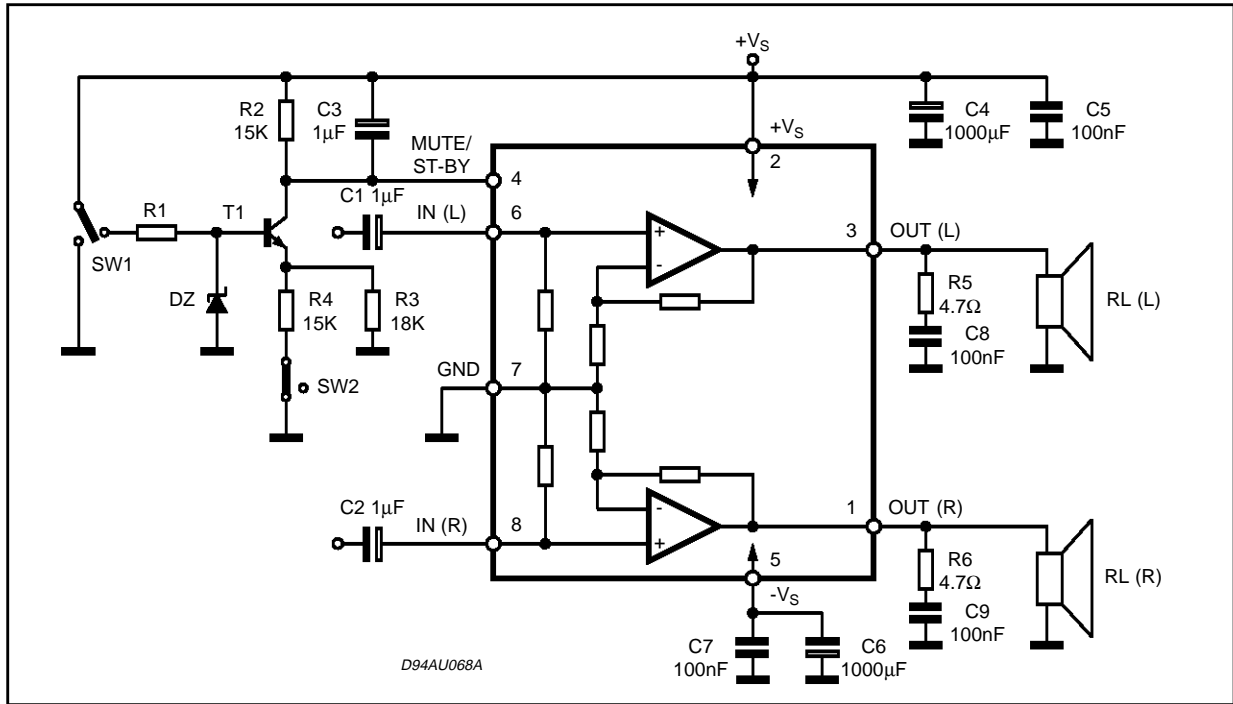
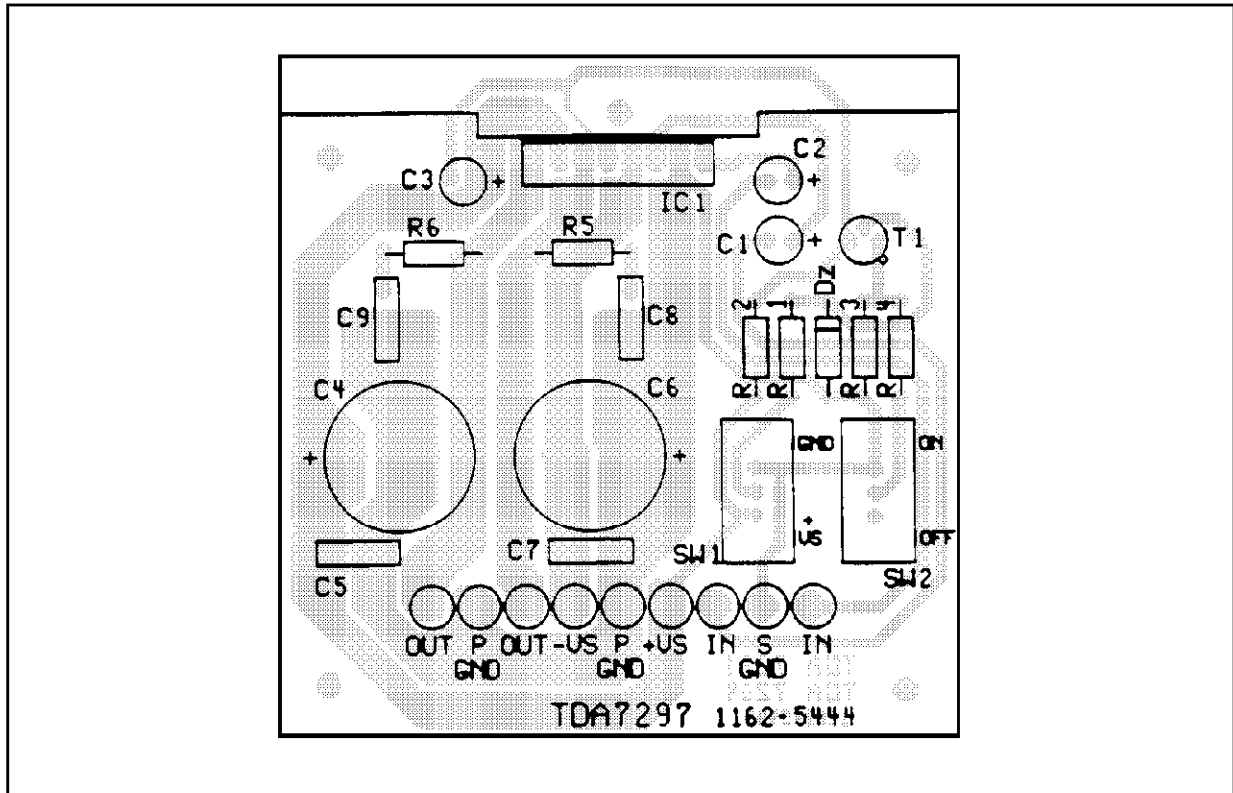

Figure 3: Demo Board Schematic



MUTE STAND-BY FUNCTION

The pin 4 (MUTE/STAND-BY) controls the amplifier status by two different thresholds, referred to +Vs.

- When V_{pin4} higher than $= +V_s - 2.5V$ the amplifier is in Stand-by mode and the final stage generators are off

- when V_{pin4} is between $+V_s - 2.5V$ and $+V_s - 6V$ the final stage current generators are switched on and the amplifier is in mute mode
- when V_{pin4} is lower than $+V_s - 6V$ the amplifier is play mode.

Figure 4: Attenuation & Total Quiescent Current vs. V_{pin4} Voltage

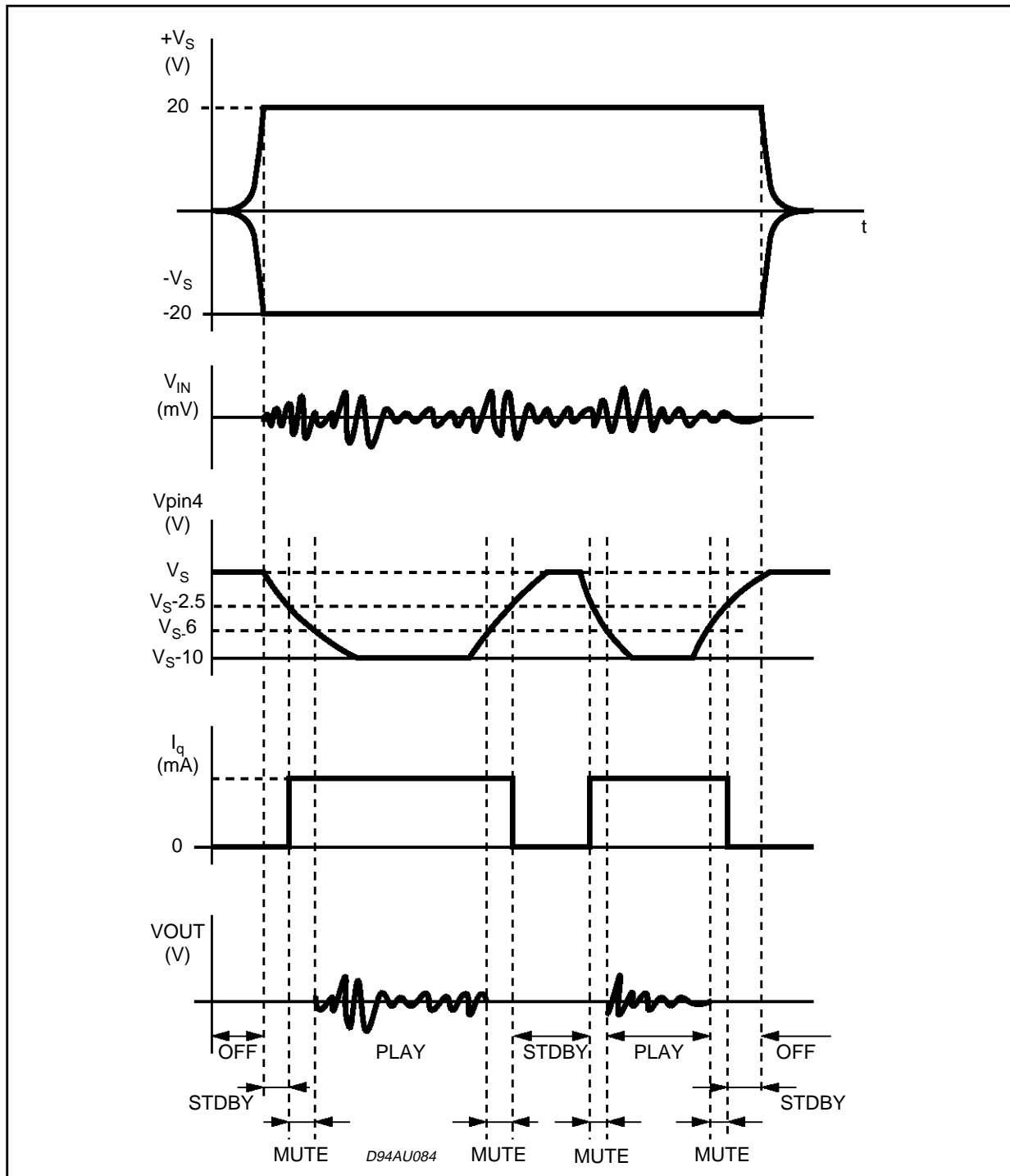

MULTIWATT8 PACKAGE MECHANICAL DATA

DIM.	mm			inch		
	MIN.	TYP.	MAX.	MIN.	TYP.	MAX.
A			5			0.197
B			2.65			0.104
C			1.6			0.063
E	0.49		0.55	0.019		0.022
F	0.78		0.85	0.030		0.033
F1	0.68		0.75	0.027		0.029
G	2.40	2.54	2.68	0.094	0.10	0.105
G1	17.64	17.78	17.92	0.69	0.70	0.71
H1	19.6			0.772		
H2			20.2			0.795
L	20.35		20.65	0.80		0.81
L1		15.7			0.62	
L2	17.05	17.20	17.35	0.67	0.68	0.68
L3	17.25	17.5	17.75	0.679	0.689	0.699
L4	10.3	10.7	10.9	0.406	0.421	0.429
L5	15.45		15.75	0.61		0.62
L7	2.65		2.9	0.104		0.114
S	1.9		2.6	0.075		0.102
S1	1.9		2.6	0.075		0.102
U	0.40		0.55	0.015		0.022
Z	0.70		0.85	0.028		0.034
Dia1	3.65		3.85	0.144		0.152

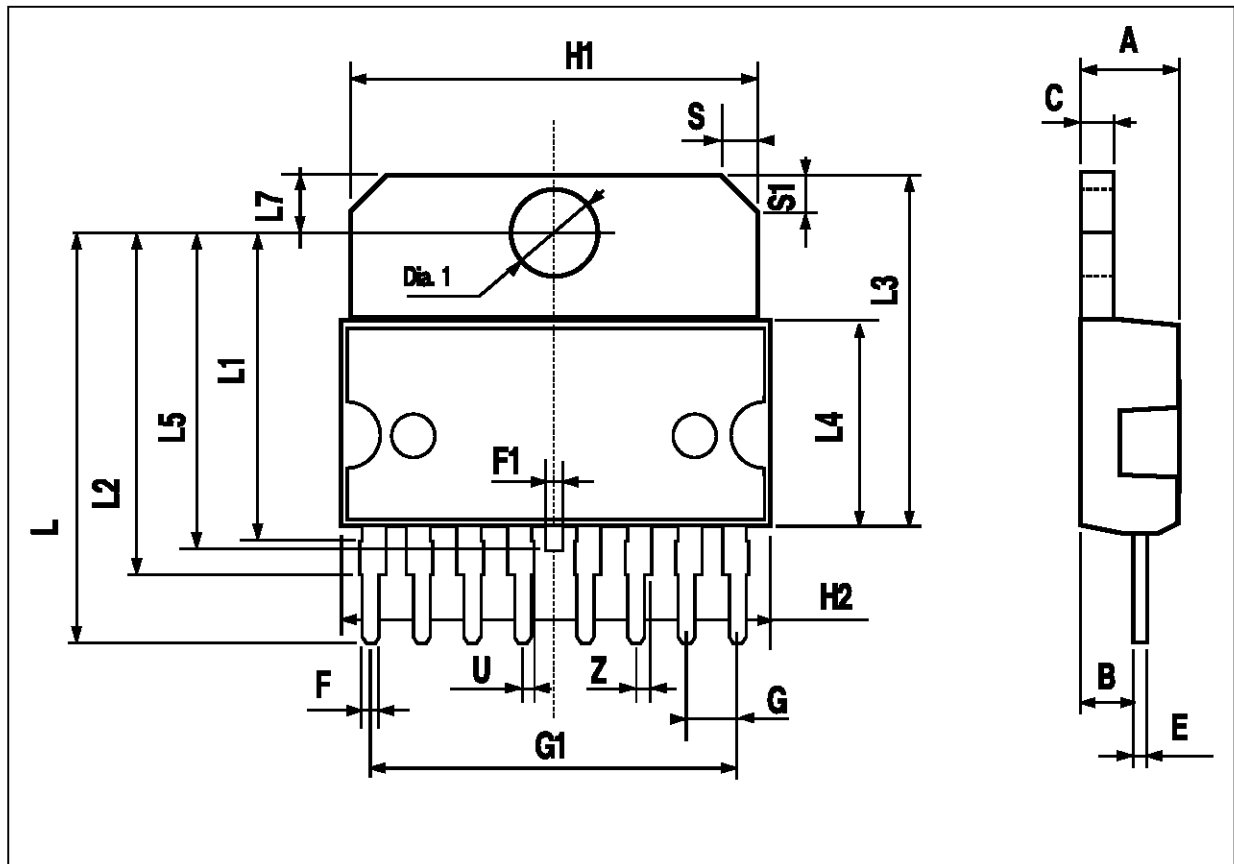

Information furnished is believed to be accurate and reliable. However, SGS-THOMSON Microelectronics assumes no responsibility for the consequences of use of such information nor for any infringement of patents or other rights of third parties which may result from its use. No license is granted by implication or otherwise under any patent or patent rights of SGS-THOMSON Microelectronics. Specifications mentioned in this publication are subject to change without notice. This publication supersedes and replaces all information previously supplied. SGS-THOMSON Microelectronics products are not authorized for use as critical components in life support devices or systems without express written approval of SGS-THOMSON Microelectronics.

© 1994 SGS-THOMSON Microelectronics - All Rights Reserved

SGS-THOMSON Microelectronics GROUP OF COMPANIES
Australia - Brazil - France - Germany - Hong Kong - Italy - Japan - Korea - Malaysia - Malta - Morocco - The Netherlands
Singapore - Spain - Sweden - Switzerland - Taiwan - Thailand - United Kingdom - U.S.A.