

SANYO	No. -	LA7322
		Monolithic Linear IC Single-Chip HQ Luminance Signal Processor

TENTATIVE

The LA7322 is a single-chip HQ (High Quality) VTR luminance signal processor IC that contains a detail enhancer, a line noise canceler, etc. The LA7322 can be used in conjunction with preamp/recording amp ICs LA7320 (2-head use) or LA7321 (4-head use) to perform all the functions of luminance signal processing.

Features

- Very streamlined IC that is placed in very small-sized package (LA7322:DIP30S) and use a minimum number of external parts. (There are no other ICs of this type that use less external parts than those the LA7322 uses.)
- Adjustment-free E/E level, white/dark clip level
- On-chip 75Ω video driver
- On-chip edit control function
- The video AGC range is so wide and satisfactory as to be suitable for copy guard.
- Excellent picture stability at the special PB mode because of on-chip PB dark clip circuit

Functions**REC section**

Video AGC, detail enhancer, nonlinear preemphasis, main preemphasis, white clip, dark clip, FM modulation $1/2f_H$ carrier shift

PB section

FM AGC, dropout compensation (base band), double limiter, FM demodulation, dynamic de-emphasis, line noise canceler, noise canceler, sync expansion, Y/C mix, muting, pseudo V insertion, pseudo H insertion, white peak clip, picture control, PB dark clip

REC/PB

Sync separation, sync chip clamp, feedback clamp, video amp, 75Ω video driver

Case Outline 3061-D30SIC
(unit: mm)

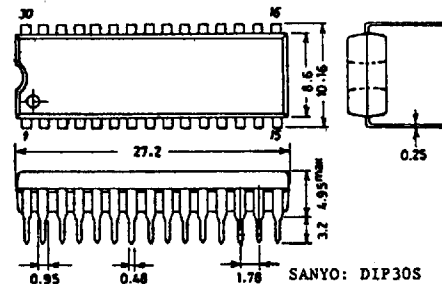

Information (including circuit diagrams and circuit parameters) herein is for example only; it is not guaranteed for volume production. SANYO believes information herein is accurate and reliable, but no guarantees are made or implied regarding its use or any infringements of intellectual property rights or other rights of third parties.

Specifications and information herein are subject to change without notice.

SANYO Electric Co., Ltd. Semiconductor Overseas Marketing Div.
Natsume Bldg., 18-6, 2-chome, Yushima, Bunkyo-ku, TOKYO 113 JAPAN.

7160TS(KOTO)LA7322-1/13

LA7322

Maximum Ratings at Ta = 25°C

Maximum Supply Voltage	V _{CC} max	7.0	V
Allowable Power Dissipation	Pd max Ta = 65°C	600	mW
Operating Temperature	Topg	-10 to +65	°C
Storage Temperature	Tstg	-40 to +125	°C

Operating Conditions at Ta = 25°C

Supply Voltage	V _{CC}	5.0	V
Operating Voltage Range	V _{CC op}	4.8 to 5.5	V

Operating Characteristics at Ta = 25°C, V_{CC} = 5.0V

No.	Characteristic	Symbol	Test Conditions		min	typ	max	unit
			Input	Output				
	(REC Mode)							
1	Current Dissipation REC	I _{CCR}	T22		50	65	80	mA
2	AGC Control	C _{AGC}	T24	T6	Vi: 1.0Vp-p video (0dB) Adjust VR2 so that output 0.5 Vp-p is obtained.			
3	AGC Control Voltage	V _{AOC}	T24	T19	Vi: 1.0Vp-p video, output DC level			
4	AGC Detection Voltage	V _{AD}	T24	T27	Vi: 1.0Vp-p video, output DC level			
5	EE Output Level-1	V _{EE1}	T24	T21A	Vi: 1.0Vp-p video, output level			
6	EE Output Level-2	V _{EE2}	T24	T21A	Vi: 4.0Vp-p video, output level			
7	AGC Control Characteristic-1	AGC1	T24	T7	(+12dB) Vi: 4.0Vp-p video, output level			
8	AGC Control Characteristic-2	AGC2	T24	T7	(+6dB) Vi: 2.0Vp-p video, output level			
9	AGC Control Characteristic-3	AGC3	T24	T7	(-6dB) Vi: 0.5Vp-p video, output level			
10	AGC Control Characteristic-4	AGC4	T24	T7	Vi: 0.7Vp-p lumi (+12dB sync) Vi: 1.2Vp-p sync sync level			
11	AGC Control Characteristic-5	AGC5	T24	T7	Vi: 0.7Vp-p lumi (+6dB sync) Vi: 0.6Vp-p sync sync level			
12	AGC Control Characteristic-6	AGC6	T24	T7	Vi: 0.7Vp-p lumi (-6dB sync) Vi: 0.15Vp-p sync sync level			

Note) The AGC characteristics must meet the copy guard test tape (VAG-1) requirements. (AGC level 40% or less)

Continued on next page.

LA7322

Continued from preceding page.

No.	Characteristic	Symbol	Test Conditions		min	typ	max	unit	
			Input	Output					
	(REC Mode)								
13	Sync Separation Output Level	V _{SY}	T24	T17	V _i : 1.0V _{p-p} video, output pulse peak	3.5	3.8	4.4	V _{p-p}
14	Sync Separation Pulse Width	P _{WSY}	T24	T17	V _i : 1.0V _{p-p} video, output pulse width	4.0	4.3	4.6	μs
15	Sync Separation Leading Edge Delay Time	Δ _{t_{SY}}	T24	T17	V _i : 1.0V _{p-p} video	1.0	1.4	1.8	μs
16	Sync Separation Threshold Level	T _{HSY}	T24	T17	Input level 1.0V _{p-p} : 0dB when input level is attenuated and output pulse width becomes wider than sync separation pulse width by 1μs.		-16	-14	dB
17	Pre Emphasis Voltage Gain	G _{PE}	T6A	T2	V _i : 500mV _{p-p} (0dB) f: 10kHz	-1.0	0	0.5	dB
18	Detail Enhancer Response Characteristic-1	G _{DE1}	T6A	T2	V _i : 500mV _{p-p} (0dB) f: 2MHz G _{PE} : 0dB	0	0.15	0.5	dB
19	Detail Enhancer Response Characteristic-2	G _{DE2}	T6A	T2	V _i : 158mV _{p-p} (-10dB) f: 2MHz G _{PE} : 0dB	0.3	0.6	0.9	dB
20	Detail Enhancer Response Characteristic-3	G _{DE3}	T6A	T2	V _i : 50mV _{p-p} (-20dB) f: 2MHz G _{PE} : 0dB	1.3	1.9	2.5	dB
21	Detail Enhancer Response Characteristic-4	G _{DE4}	T6A	T2	V _i : 15.8mV _{p-p} (-30dB) f: 2MHz G _{PE} : 0dB	1.9	2.5	3.1	dB
22	Detail Enhancer Response Characteristic-5	G _{DE5}	T6A	T2	V _i : 5mV _{p-p} (-40dB) f: 2MHz G _{PE} : 0dB	1.9	2.7	3.5	dB
23	Nonlinear Emphasis Response Characteristic-1	G _{NE1}	T6A	T2	V _i : 500mV _{p-p} (0dB) f: 2MHz G _{PE} : 0dB	0.5	1.4	2.3	dB
24	Nonlinear Emphasis Response Characteristic-2	G _{NE2}	T6A	T2	V _i : 158mV _{p-p} (-10dB) f: 2MHz G _{PE} : 0dB	2.6	3.8	5.2	dB
25	Nonlinear Emphasis Response Characteristic-3	G _{NE3}	T6A	T2	V _i : 50mV _{p-p} (-20dB) f: 2MHz G _{PE} : 0dB	4.9	6.4	7.9	dB
26	Nonlinear Emphasis Response Characteristic-4	G _{NE4}	T6A	T2	V _i : 158mV _{p-p} (-10dB) f: 200kHz G _{PE} : 0dB	0.7	1.4	2.1	dB
27	Main Emphasis Response Characteristic-1	G _{ME1}	T6A	T2	V _i : 50mV _{p-p} (-20dB) f: 200kHz G _{PE} : 0dB	4.9	5.2	5.5	dB
28	Main Emphasis Response Characteristic-2	G _{ME2}	T6A	T2	V _i : 50mV _{p-p} (-20dB) f: 2MHz G _{PE} : 0dB	13.1	13.6	14.1	dB
29	White Clip Level	L _{WC}	T6A	T2	V _i : 0.5V _{p-p} video	187	195	203	%
30	Dark Clip Level	L _{DC}	T6A	T2	V _i : 0.5V _{p-p} video	-48	-55	-62	%

Continued on next page.

T-77-07-09

LA7322

Continued from preceding page.

No.	Characteristic	Symbol	Test Conditions		min	typ	max	unit	
			Input	Output					
(REC Mode)									
31	FM Modulator Output Level	V_{FM}	-	T30	Output level when output frequency is set to 4MHz with VRI at no load mode	1.3	1.5	1.7	V _{p-p}
32	FM Modulator 2nd Distortion	H_{MOD}	T6	T30	8MHz component / 4MHz component ratio obtained in above-mentioned state		-40	-35	dB
33	FM Modulator Modulation Sensitivity	S_{MOD}	T6	T30	Output frequency change $2 \times ((4.0 - f_{3.5})$ when DC 3.5V, 4.5V are applied to pin 6	1.6	2.0	2.4	MHz
34	FM Modulator Linearity	L_{MOD}	T6	T30	Output frequency when 3.75V DC is applied to pin 6 : $f_{3.75}$ $L_{MOD} = \frac{f_{3.75} - (f_{4.0} + f_{3.5})/2}{S_{MOD}} \times 100$	-3.0	0	3.0	%
35	EP 1/2 Carrier Shift-1	C_{g1}	T6	T2	Output frequency change at SW12: 1 SW13: 1→2	6.0	7.5	9.0	kHz
(PB Mode)									
1	Current Dissipation	I_{CCP}	T22		Pin 22 flow-in current at $V_{CC} = 5.0V$	65	80	95	mA
2	FM AGC Detection Voltage-1	V_{FD1}	T26	T27	V_i : 200mV _{p-p} (0dB) f : 4MHz	0.80	0.90	1.00	V
3	FM AGC Detection Voltage-2	V_{FD2}	T26	T27	V_i : 400mV _{p-p} (+6dB) f : 4MHz	1.05	1.15	1.25	V
4	FM AGC Detection Voltage-3	V_{FD3}	T26	T27	V_i : 50mV _{p-p} (-12dB) f : 4MHz	0.59	0.69	0.79	V
5	Dropout Detection Level	L_{DOC1}	T26	T28	Input level when T28 Low→High is caused by input f : 4MHz High→Low	4.0	5.0	6.0	mV PP
6	Dropout Reset Level	L_{DOC2}	T26	T28	Input level when T28 High→Low is caused by input f : 4MHz High→Low	4.8	6.0	7.2	mV PP
7	Dropout Detection Pulse Output Level	V_{DOC}	-	T28	Output DC level at no input mode	3.5	3.9	4.4	V _{p-p}
8	FM Demodulation Voltage-1	V_{DEM4} (1)	T26	T7A	V_i : 200mV _{p-p} (0dB) f : 4MHz output voltage	1.1	1.30	1.5	V
9	FM Demodulation Voltage-2	V_{DEM4} (2)	T26	T7A	V_i : 400mV _{p-p} (+6dB) f : 4MHz output voltage	1.1	1.30	1.5	V
10	FM Demodulation Voltage-3	V_{DEM4} (3)	T26	T7A	V_i : 50mV _{p-p} (-12dB) f : 4MHz output voltage	1.1	1.30	1.5	V

Continued on next page.

LA7322

Continued from preceding page,

No.	Characteristic	Symbol	Test Conditions		min	typ	max	unit	
			Input	Output					
(PB Mode)									
11	FM Demodulation Sensitivity-1	S _{DEM(1)}	T26	T7A	Vi: 200mVp-p,f: 2MHz output voltage V _{DEM2(1)} Vi: 200mVp-p,f: 6MHz output voltage V _{DEM6(1)} Calculate using S _{DEM(1)} = (V _{DEM2(1)} - V _{DEM6(1)}) / 4	0.16	0.20	0.24	V/ MHz
12	FM Demodulation Sensitivity-2	S _{DEM(2)}	T26	T7A	Vi: 400mVp-p,f: 2MHz output voltage V _{DEM2(2)} Vi: 400mVp-p,f: 6MHz output voltage V _{DEM6(2)} Calculate using S _{DEM(2)} = (V _{DEM2(2)} - V _{DEM6(2)}) / 4	0.16	0.20	0.24	V/ MHz
13	FM Demodulation Sensitivity-3	S _{DEM(3)}	T26	T7A	Vi: 50mVp-p,f: 2MHz output voltage V _{DEM2(3)} Vi: 50mVp-p,f: 6MHz output voltage V _{DEM6(3)} Calculate using S _{DEM(3)} = (V _{DEM2(3)} - V _{DEM6(3)}) / 4	0.16	0.20	0.24	V/ MHz
14	FM Demodulation Linearity-1	L _{DEM(1)}	-	-	$L_{DEM(1)} = \frac{V_{DEM4(1)} - (V_{DEM2(1)} + V_{DEM6(2)}) / 2}{V_{DEM2(1)} - V_{DEM6(1)}} \times 100$	-3.5	0	3.5	%
15	FM Demodulation Linearity-2	L _{DEM(2)}	-	-	$L_{DEM(1)} = \frac{V_{DEM4(1)} - (V_{DEM2(1)} + V_{DEM6(2)}) / 2}{V_{DEM2(2)} - V_{DEM6(2)}} \times 100$	-3.5	0	3.5	%
16	FM Demodulation Linearity-3	L _{DEM(3)}	-	-	$L_{DEM(1)} = \frac{V_{DEM4(1)} - (V_{DEM2(1)} + V_{DEM6(2)}) / 2}{V_{DEM2(3)} - V_{DEM6(3)}} \times 100$	-3.5	0	3.5	%
17	Carrier Leak-1	C _{L(1)}	T26	T7	Vi: 200mVp-p,f: 4MHz Output frequency 4MHz component / 8MHz compo- nent ratio		-40	-35	dB
18	Carrier Leak-2	C _{L(2)}	T26	T7	Vi: 400mVp-p,f: 4MHz Output frequency 4MHz component / 8MHz compo- nent ratio		-40	-35	dB
19	Carrier Leak-3	C _{L(3)}	T26	T7	Vi: 50mVp-p,f: 4MHz Output frequency 4MHz component / 8MHz compo- nent ratio		-40	-35	dB

Continued on next page.

T-77-07-09

LA7322

Continued from preceding page.

No.	Characteristic	Symbol	Test Conditions		min	typ	max	unit	
			Input	Output					
	(PB Mode)								
20	PB Output Level (Through Gain)	V_{PB}	T9.10	T21A	$V_i: 300mV_{p-p}$ (0dB) $f: 10kHz$	4.8	5.8	6.8	dB
21	PB Output Frequency Characteristic	F_{PB}	T9.10	T21A	$V_i: 300mV_{p-p}, f: 3MHz$ Output level / V_{PB} (10kHz)	-0.6	-0.3	0	dB
22	Noise Limiter Level	N_{LIM}	T10	T21A	$V_i: 100mV_{p-p}$ $f: 100kHz$	45	60	72	mV pp
23	Noncorrelation Detection Level	L_N		T11	T10: 3.9V, T9: 3.9V, ΔV when voltage only applied to T9 is increased and T11 output level is changed from Low to High	65	80	95	mV
24	Noncorrelation Detection Pulse Output Level	V_H		T11	Output level when above-mentioned T11 output is at High	3.5	3.8	4.4	V _{p-p}
25	De-emphasis Response Characteristic-2	G_{D2}	T9.10	T21A	$V_i: 158mV_{p-p}$ (-10dB) $f: 2MHz$ $V_{PB}: 0dB$	-3.1	-2.2	-1.3	dB
26	De-emphasis Response Characteristic-3	G_{D3}	T9.10	T21A	$V_i: 50mV_{p-p}$ (-20dB) $f: 2MHz$ $V_{PB}: 0dB$	-4.7	-3.8	-2.9	dB
27	De-emphasis Response Characteristic-4	G_{D4}	T9.10	T21A	$V_i: 158mV_{p-p}$ (-10dB) $f: 200kHz$ $V_{PB}: 0dB$	-1.2	-0.7	-0.2	dB
28	HP-noise Canceler Response Characteristic-1	G_{N1}	T9.10	T21A	$V_i: 158mV_{p-p}$ (-10dB) $f: 1MHz$ $V_{PB}: 0dB$	-1.7	-1.2	-0.7	dB
29	HP-noise Canceler Response Characteristic-2	G_{N2}	T9.10	T21A	$V_i: 50mV_{p-p}$ (-20dB) $f: 1MHz$ $V_{PB}: 0dB$	-4.3	-3.3	-2.3	dB
30	HP-noise Canceler Response Characteristic-3	G_{N3}	T9.10	T21A	$V_i: 15.8mV_{p-p}$ (-30dB) $f: 1MHz$ $V_{PB}: 0dB$	-10.0	-8.5	-7.0	dB
31	PIC-cont Hardware Response Characteristic-1	G_{PH1}	T9.10	T21A	$V_i: 150mV_{p-p}$ $f: 1MHz$ $V_{PB}: 0dB$	2.7	3.7	4.7	dB
32	PIC-cont Hardware Response Characteristic-2	G_{PH2}	T9.10	T21A	$V_i: 150mV_{p-p}$ $f: 2MHz$ $V_{PB}: 0dB$	4.9	5.9	6.9	dB
33	PIC-cont Software Response Characteristic-1	G_{PS1}	T9.10	T21A	$V_i: 150mV_{p-p}$ $f: 1MHz$ $V_{PB}: 0dB$	-4.0	-3.0	-2.0	dB
34	PIC-cont Software Response Characteristic-2	G_{PS2}	T9.10	T21A	$V_i: 150mV_{p-p}$ $f: 2MHz$ $V_{PB}: 0dB$	-7.6	-6.6	-5.6	dB
35	Chroma Amp Voltage Gain	G_C	T19A	T21	$V_i: 100mV_{p-p}$ $f: 3MHz$	11.0	12.0	13.0	dB

Continued on next page.

LA7322

Continued from preceding page.

No.	Characteristic	Symbol	Test Conditions		min	typ	max	unit		
			Input	Output						
	(PB Mode)									
36	Chroma Amp Frequency Characteristic	F_C	T19A	T21	Vi: 100mVp-p, f: 4MHz, output level/ G_C (3MHz) output ratio		-0.5	0	dB	
37	Sync Expansion Ratio	L_{SYNC}	T9.10	T21	Vi: 0.5Vp-p video (lumi: 0.35, sync: 0.15) Sync / output peak ratio		30.0	31.5	33.0	%
38	Pseudo V Insertion Level	L_{VD}	T9.10	T21	Vi: 0.5Vp-p video Output DC difference between output sync chip potential at S11: 1 and output sync chip potential at S11: 3		-80	0	+80	mV
39	Pseudo H Insertion Level	L_{HD}	T9.10	T21	Vi: 0.5Vp-p video Output DC difference between output pedestal potential at S11: 1 and output pedestal potential at S11: 2		0	75	150	mV
40	PB Peak Clip Level	P_C	T9.10	T21	Vi: 0.75Vp-p video Output peak		2.4	2.5	2.6	Vp-p
41	DS Amp Voltage Gain	G_{DS}	T9	T12	Vi: 500mVp-p f: 10kHz		-0.5	0	0.5	dB

LA7322

LA7322 Block Diagram

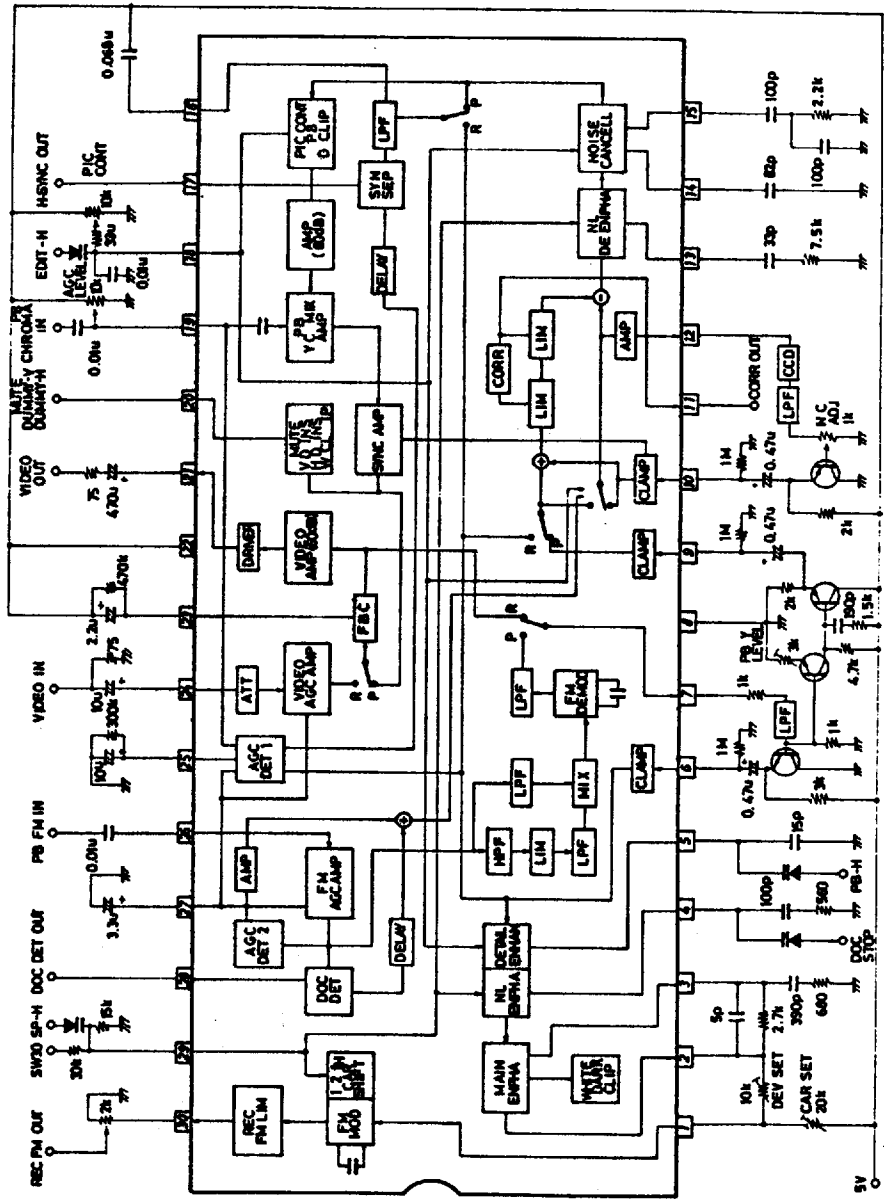

T-77-07-09

LA7322

LA7322 Test Circuit

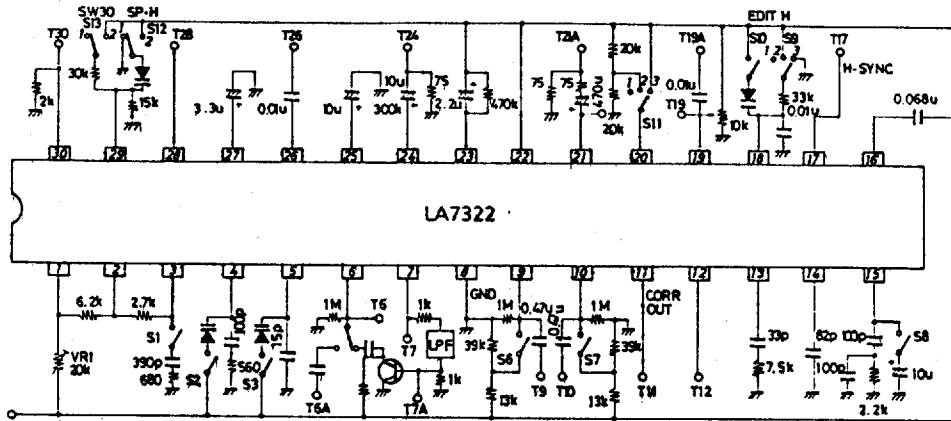

Description of Control Pins
(Control Voltage Mode)

Item	L	M	H
R/P mode Pin 5	REC mode		3.9V or greater PB mode
DOC stop Pin 4	DOC ON		3.6V or greater DOC OFF
Edit mode Pin 18	EDIT OFF		3.6V or greater EDIT ON
Mute, VD, HD Pin 21	1.5V or less Normal	1.9V to 3.2V Pedestal mute	3.6V or greater Synch mute
SW30 1/2fH carrier shift Pin 29	0.9V or less Lch (+7.5kHz)		1.1V to 1.9V Hch
SP mode Pin 29	1.8V or less EP mode		2.4V or greater SP mode

(Mode Description)

Mode	EDIT	Detail	NL PreEmpha	LINE NOICAN	NL DeEmpha	PIÇ Control
SP	ON	OFF	OFF	OFF	OFF	OFF
	OFF	ON	OFF	ON	OFF	ON
EP	ON	OFF	ON	OFF	ON	OFF
	OFF	ON	ON	ON	ON	ON

T-77-07-09

LA7322

Pin Description

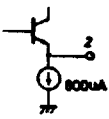
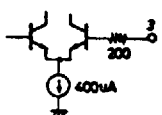
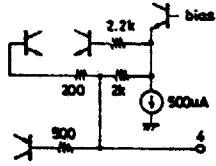
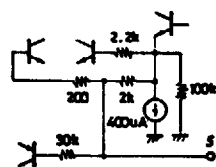
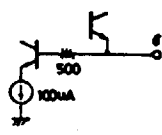
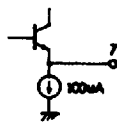
Pin No.	Pin Function	Interface	Typical DC	Remarks
1	FM MOD-IN		$\frac{2.4}{(3.4)}$	
2	PRE-MEPH OUT		$\frac{2.4}{(2.5)}$	
3	MAIN-EMPH FEEDBACK IN		$\frac{2.4}{(2.2)}$	
4	NL-EMPH FIL DOC STOP		$\frac{2.95}{(2.75)}$	
5	DETAIL-FIL PB-H		$\frac{2.55}{}$	
6	REC CLAMP-IN		$\frac{3.2}{}$	
7	REC AGC OUT PB DEMOD OUT		$\frac{V_{sync}}{2.35}$	
8	GND			

Continued on next page.

LA7322

Continued from preceding page.

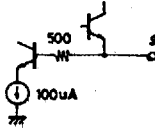
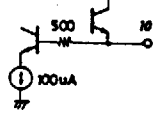
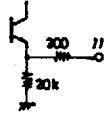
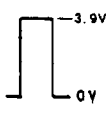
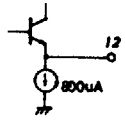
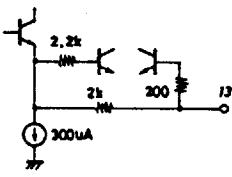
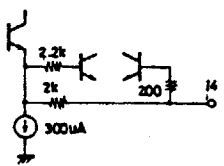
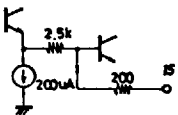
Pin No.	Pin Function	Interface	Typical DC	Remarks
9	PB CLAMP-IN		3.2	
10	YD CLAMP-IN		3.2 3.2	
11	CORR DET. OUT			
12	CCD DRIVE		2.75 2.75	
13	N.L DE-EMPHA FIL		(4.5) 2.8	
14	NOICAN FIL-1		(4.5) 2.8	
15	NOICAN FIL-2		(4.5) 4.15	

Continued on next page.

T-77-07-09

LA7322

Continued from preceding page.

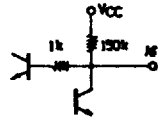
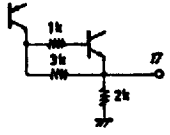
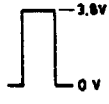
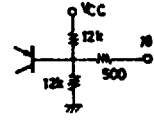
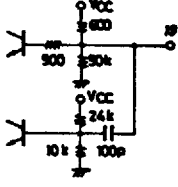
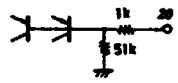
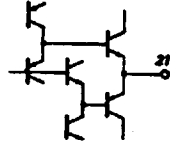
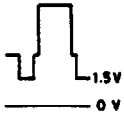
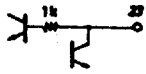
Pin No.	Pin Function	Interface	Typical DC	Remarks
16	SYNC SEP FIL		$\frac{3.5}{3.5}$	
17	H-SYNC-OUT			
18	PIC-CONT			
19	PB CHROMA IN		$\frac{3.7}{3.9}$	
20	MUTE DUMMY-V DUMMY-H			
21	VIDEO-OUT			
22	Vcc			
23	F.B.C-FIL		$\frac{3.2}{3.2}$	

Continued on next page.

LA7322

Continued from preceding page.

Pin No.	Pin Function	Interface	Typical DC	Remarks
24	VIDEO-IN		$\frac{3.3}{3.3}$	
25	AGC-FIL-1		$\frac{3.1}{(4.0)}$	
26	PB-FM-IN		$\frac{(3.6)}{3.7}$	
27	AGC-FIL-2		$\frac{1.4}{0.9}$	
28	DOC DET OUT			
29	SP-H SW-30			
30	REQ-FM-OUT			