

Low-current audio headphone driver

BA3574BFS

The BA3574BFS is a headphone driver with a fixed-gain bass boost circuit and an AVC circuit that keeps the output below a fixed level. It features low current dissipation, and low output noise, and is ideal for use in portable digital audio equipment.

●Applications

Portable CD and MD players

●Features

- 1) Low current dissipation (when $V_{CC} = 2.4V$, the quiescent current is 4.9mA).
- 2) Suitable for use in digital audio equipment (voltage gain: $G_V = 11.8dB$, output noise voltage: $V_{NO} = -102dBm$ typ.).
- 3) Bass boost circuit.
- 4) AVC (Auto Volume Control) circuit, for output limiting.
- 5) Standby switch.
- 6) Mute switch.
- 7) Ripple filter.
- 8) No output coupling capacitor required.
- 9) Beep circuit.
- 10) SSOP-A20 package.

●Block diagram

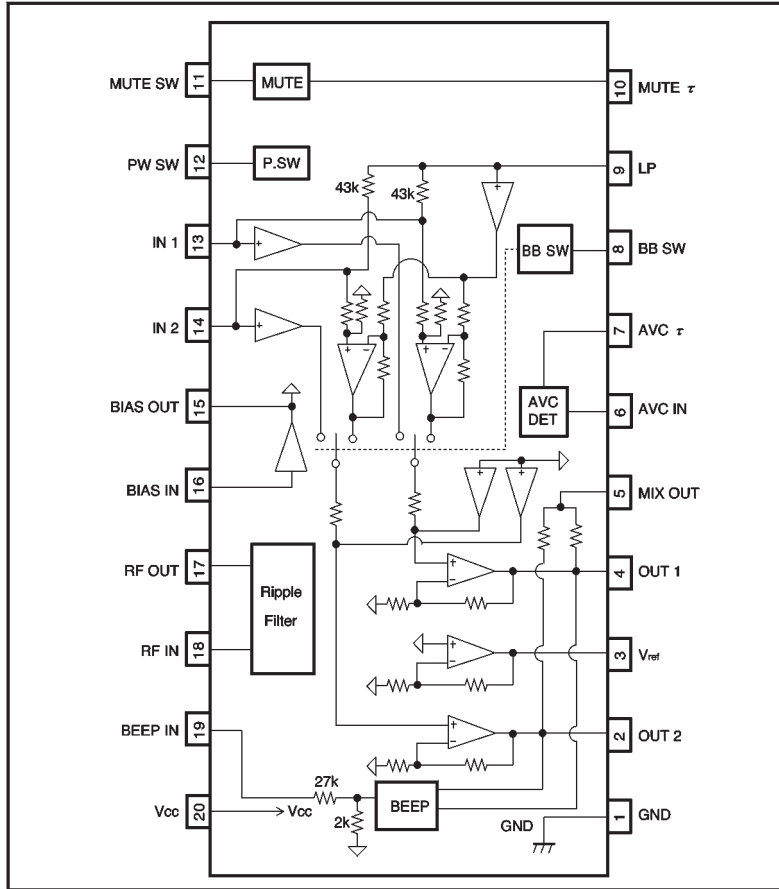

●Absolute maximum ratings (Ta = 25°C)

Parameter	Symbol	Limits	Unit
Power supply voltage	V _{CC}	9.0	V
Power dissipation	P _d	600*	mW
Operating temperature	T _{opr}	-25~+75	°C
Storage temperature	T _{stg}	-55~+125	°C

* Reduced by 6.0mW for each increase in Ta of 1°C over 25°C.

●Recommended operating conditions (Ta = 25°C)

Parameter	Symbol	Min.	Typ.	Max.	Unit
Power supply voltage	V _{CC}	1.7	—	3.6	V

* When V_{CC} ≥ 3.6V, do not exceed the maximum allowable output power (see Fig. 5).

●Electrical characteristics (unless otherwise noted, Ta = 25°C, Vcc = 2.4V, RL = 16Ω, f = 1kHz, and BB = OFF)

Parameter	Symbol	Min.	Typ.	Max.	Unit	Conditions
Circuit current 1	Icc1	—	0.2	3.0	μA	VIN=0, RL=OPEN, PW SW=OFF
Circuit current 2	Icc2	—	3.1	4.7	mA	VIN=0, RL=OPEN, MUTE=ON
Circuit current 3	Icc3	—	4.9	7.5	mA	VIN=0, RL=OPEN
Circuit current 4	Icc4	—	5.0	7.8	mA	VIN=0, RL=OPEN, BB=ON
Circuit current variation	ΔIcc	—	0.3	2.0	mA	Icc4 (RL=16Ω) - Icc4 (RL=OPEN)
Voltage gain	Gv	9.8	11.8	13.8	dB	
Rated output power 1	POUT1	19	40	—	mW	THD=10%
Rated output power 2	POUT2	8	15	—	mW	THD=10%, Vcc=1.8V
Total harmonic distortion	THD	—	0.1	0.5	%	Vo=0.3Vrms
Output noise voltage 1	VNo1	—	-102	-97	dBm	IHF-A, Rg=0
Output noise voltage 2	VNo2	—	-89	-84	dBm	IHF-A, Rg=0, BB=ON
Input resistance	RIN	11.5	16.8	22.0	kΩ	
Ripple rejection 1	RR1	73	79	—	dB	fRR=100Hz, VRR=-20dBm, Rg=0
Ripple rejection 2	RR2	53	63	—	dB	Rg=0, VRR=-20dBm, BB=ON fRR=100Hz
Ripple rejection 3	RR3	66	79	—	dB	Rg=0, VRR=-20dBm, Vcc=1.8V fRR=100Hz
Ripple rejection 4	RR4	43	58	—	dB	fRR=100Hz, VRR=-20dBm, Vcc=1.8V BB=ON, Rg=0
Bass boost	BB	4.5	7.0	9.5	dB	f=100Hz, VIN=-30dBV
AVC level	VAVC	-42.5	-40.5	-38.5	dBV	VIN=-30dBV
Channel separation	CS	24	44	—	dB	Vo=-10dBV
Mute level	ML	80	90	—	dB	VIN=-20dBV
Beep output voltage	VBEEP	1.1	3.0	5.8	mVrms	VBEEP IN=0dBV
Power ON voltage	VPW ON	—	0.95	1.4	V	
Power ON pin current	IPW SW	—	105	150	μA	VPW SW=3.0V
Mute ON voltage	VMUTE ON	—	0.95	1.4	V	
Mute ON pin current	IMUTE	—	105	150	μA	VMUTE=3.0V

©Not designed for radiation resistance.

● Measurement circuit

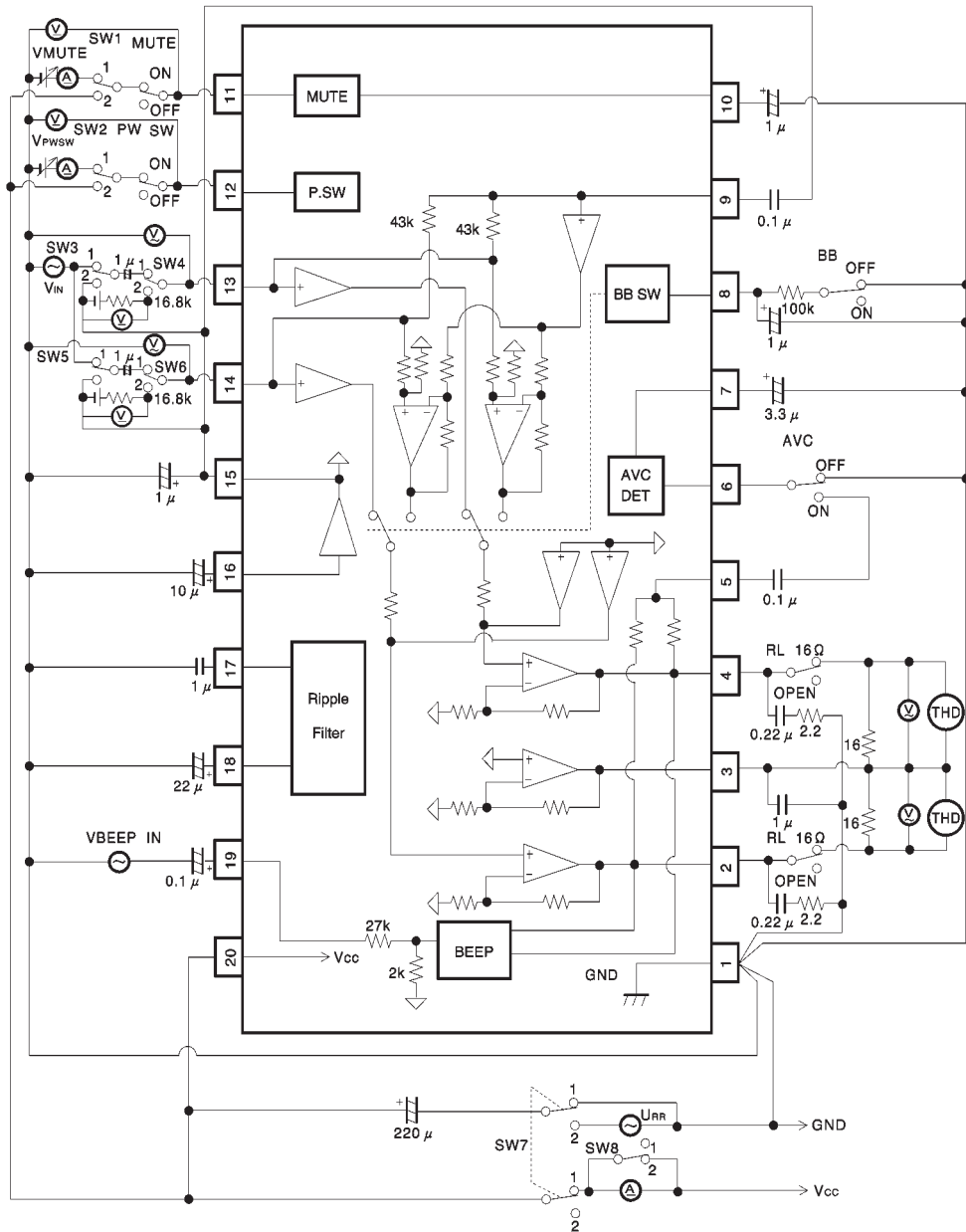

Units:
 Resistance : Ω ($\pm 1\%$)
 Capacitance (film) : F ($\pm 1\%$)
 Capacitance (electrolytic): F ($\pm 5\%$)

Fig. 1

● Measurement circuit switch table

Parameter	Symbol	MUTE	PwSw	BB	AVC	R _L	SW1	SW2	SW3	SW4	SW5	SW6	SW7	SW8
Circuit current 1	I _{cc1}	OFF	OFF	OFF	OFF	OPEN	2	2	2	1	2	1	1	1
Circuit current 2	I _{cc2}	ON	ON	↓	↓	↓	↓	↓	↓	↓	↓	↓	↓	↓
Circuit current 3	I _{cc3}	OFF	↓	↓	↓	↓	↓	↓	↓	↓	↓	↓	↓	↓
Circuit current 4	I _{cc4}	↓	↓	ON	↓	↓	↓	↓	↓	↓	↓	↓	↓	↓
Circuit current variation	ΔI _{cc}	↓	↓	↓	↓	16Ω OPEN	↓	↓	↓	↓	↓	↓	↓	↓
Voltage gain	G _v	↓	↓	OFF	↓	16Ω	↓	↓	1	↓	1	↓	↓	2
Rated output power 1	P _{out1}	↓	↓	↓	↓	↓	↓	↓	↓	↓	↓	↓	↓	↓
Rated output power 2	P _{out2}	↓	↓	↓	↓	↓	↓	↓	↓	↓	↓	↓	↓	↓
Total harmonic distortion	THD	↓	↓	↓	↓	↓	↓	↓	↓	↓	↓	↓	↓	↓
Output noise voltage 1	V _{No1}	↓	↓	↓	↓	↓	↓	↓	2	↓	2	↓	↓	↓
Output noise voltage 2	V _{No2}	↓	↓	ON	↓	↓	↓	↓	↓	↓	↓	↓	↓	↓
Input resistance	R _{in}	↓	↓	OFF	↓	↓	↓	↓	1	2	1	2	↓	↓
Ripple rejection ratio 1	RR1	↓	↓	↓	↓	↓	↓	↓	2	1	2	1	2	↓
Ripple rejection ratio 2	RR2	↓	↓	ON	↓	↓	↓	↓	↓	↓	↓	↓	↓	↓
Ripple rejection ratio 3	RR3	↓	↓	OFF	↓	↓	↓	↓	↓	↓	↓	↓	↓	↓
Ripple rejection ratio 4	RR4	↓	↓	ON	↓	↓	↓	↓	↓	↓	↓	↓	↓	↓
Bass boost	BB	↓	↓	↓	↓	↓	↓	↓	1	↓	1	↓	1	↓
AVC level	V _{AVC}	↓	↓	OFF	ON	↓	↓	↓	↓	↓	↓	↓	↓	↓
Channel separation	CS	↓	↓	↓	OFF	↓	↓	↓	1 2	↓	2 1	↓	↓	↓
Mute level	ML	ON	↓	↓	↓	↓	↓	↓	1	↓	1	↓	↓	↓
Beep output voltage	V _{BEEP}	↓	↓	↓	↓	↓	↓	↓	↓	↓	↓	↓	↓	↓
Power ON voltage	V _{PW ON}	OFF	↓	↓	↓	↓	1	1	↓	↓	↓	↓	↓	↓
Power ON pin current	I _{PW SW}	↓	↓	↓	↓	↓	↓	↓	↓	↓	↓	↓	↓	↓
Mute ON voltage	V _{MUTE ON}	ON	↓	↓	↓	↓	↓	↓	↓	↓	↓	↓	↓	↓
Mute pin current	I _{MUTE}	↓	↓	↓	↓	↓	↓	↓	↓	↓	↓	↓	↓	↓

●Application example 1

(headphone stereo with bass boost and output limiting)

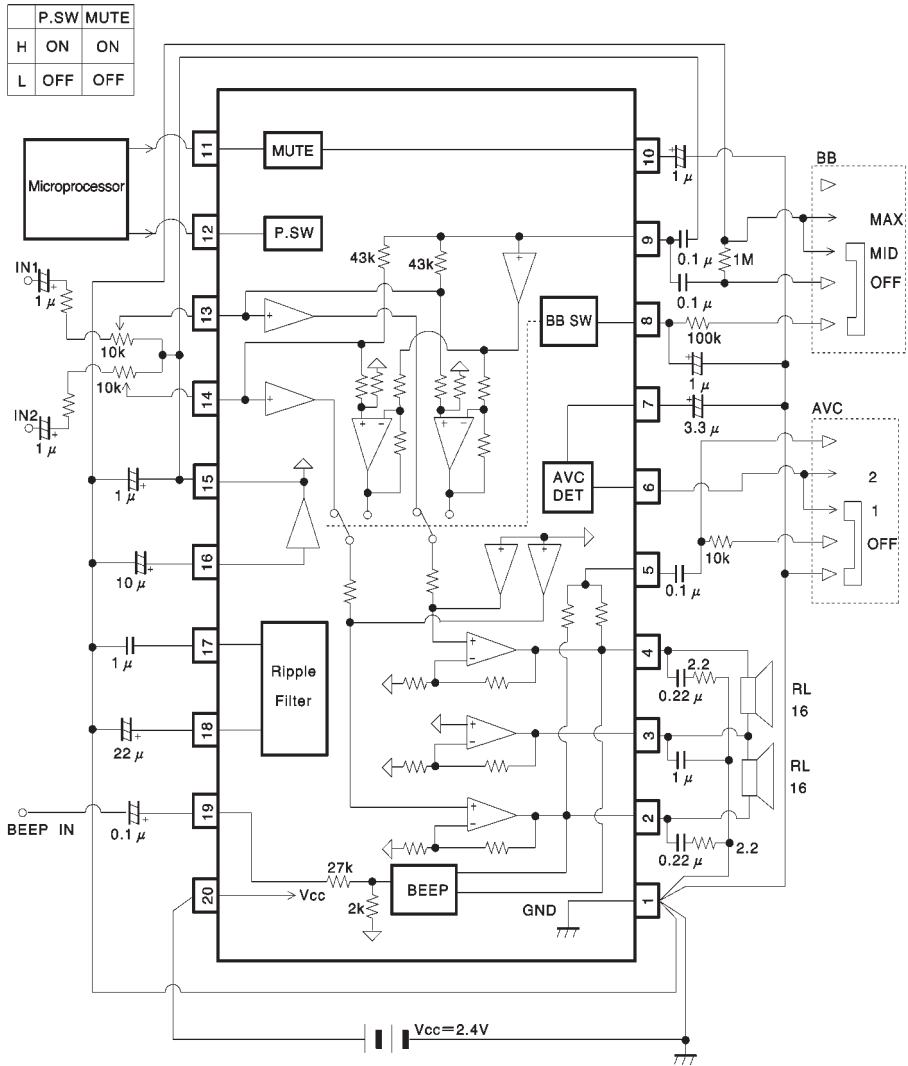

Units:
 Resistance : Ω (±5%)
 Capacitance (film) : F (±10%)
 Capacitance (electrolytic) : F (±20%)

Fig. 2

●Application example 2

(headphone stereo with bass boost)

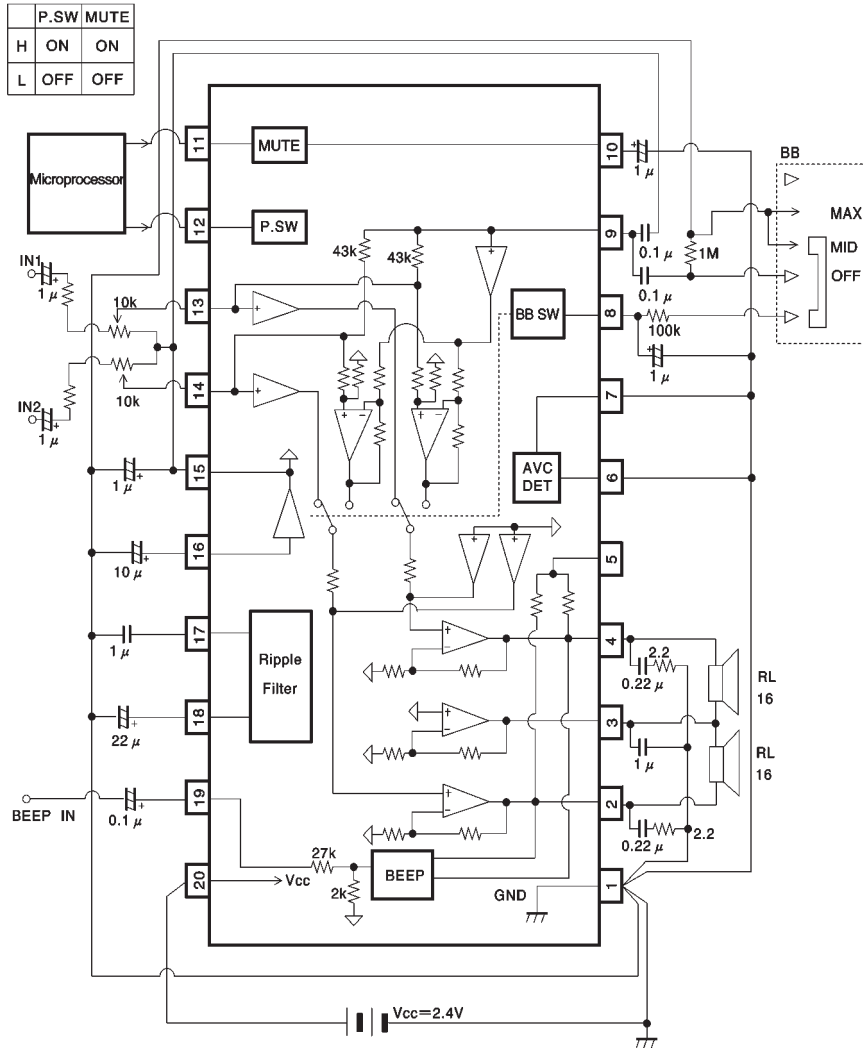

Units:
 Resistance : Ω (±5%)
 Capacitance (film) : F (±10%)
 Capacitance (electrolytic) : F (±20%)

Fig. 3

●Application example 3

(headphone stereo)

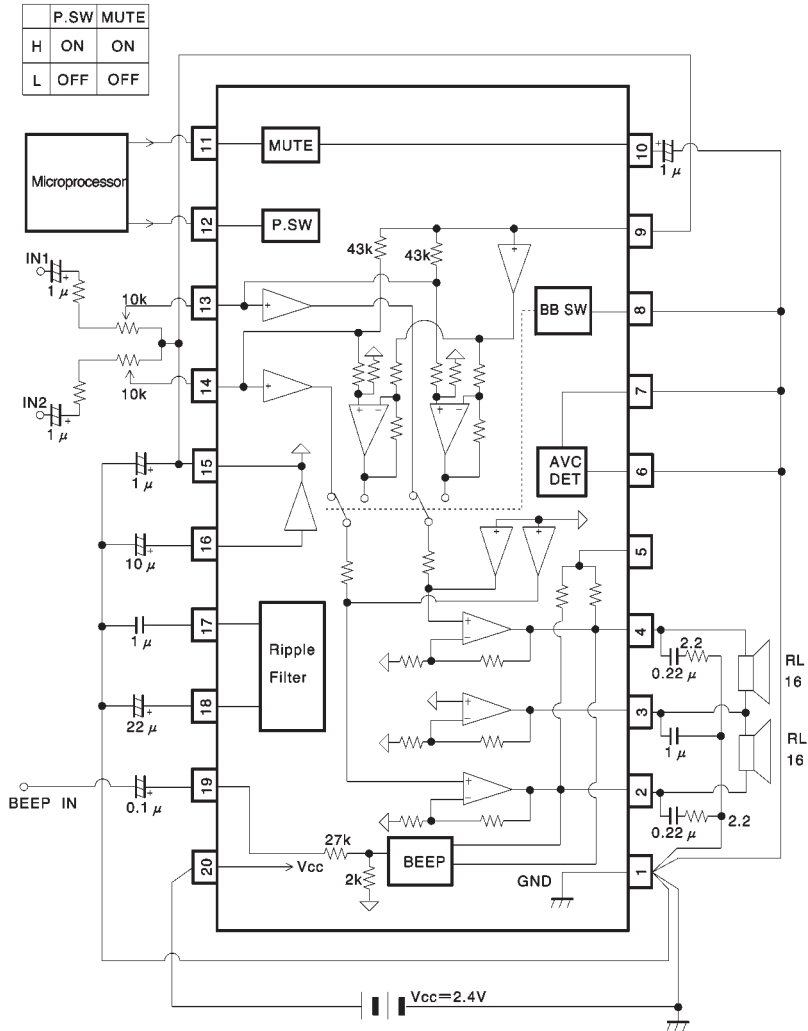

Units:
 Resistance : Ω ($\pm 5\%$)
 Capacitance (film) : F ($\pm 10\%$)
 Capacitance (electrolytic) : F ($\pm 20\%$)

Fig. 4

● Operation notes

(1) Application circuits

Provided the recommended circuit constants are used, the application circuits should function correctly. However, we recommend that you confirm the characteristics of the circuits in actual use. If you change the circuit constants, check both the static and transient characteristics of the circuit, and allow sufficient margin to accommodate variations between both ICs and external components.

In particular, the capacitors connected to the OUT 1, OUT 2, and Vref pins must have low impedance at high frequency.

(2) Wiring of PCB

The PCB pattern for the external components should be designed carefully to prevent oscillation and degradation of the circuit characteristics. Keep the wiring tracks as short as possible, and ensure that there is no impedance between the common connections.

(3) Recommended power supply voltage range

The curves in Fig. 5 below show the maximum allowable power output ($P_{O(Max.)}/ch$) plotted against the supply voltage (V_{CC}) for different values of ambient temperature (T_a). When $V_{CC} \geq 3.6V$, operate the IC in the region below the dotted line, and do not exceed it.

If the maximum allowable power output for each channel ($P_{O(Max.)}/ch$) is exceeded, the internal power consumption will exceed the power dissipation capacity of the package, and destroy the IC.

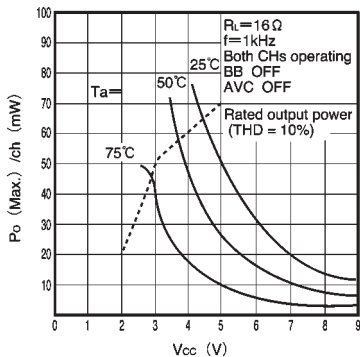
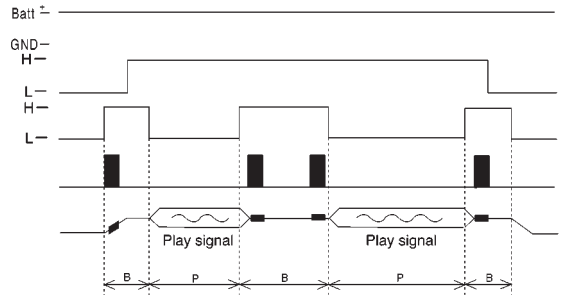

Fig. 5 Maximum allowable power output per channel ($P_{O(Max.)}/ch$) vs. power supply voltage (V_{CC}).

(4) Switching noise prevention

Operate the BA3574BFS according to the timing diagram given in Fig. 6 below to prevent a “pop” sound from being output to the headphones.



- V_{CC} (20pin)
- PWSW (12pin)
- MUTE (11pin)
- BEEP IN (19pin)
- OUT1, 2 (2, 4pin)

B: BEEP amplifier operates
P: PWR amplifier operates

PWSW (12pin)	MUTE (11pin)	PWR AMP	BEEP AMP
L	L	OFF	OFF
L	H	OFF	ON
H	H	OFF	ON
H	L	ON	OFF

Fig. 6

(5) BIAS OUT (pin 15)

The internal operating point voltage of the BA3574BFS is supplied from BIAS OUT (pin 15). The current capacity is limited, so do not use this as the operating point for external circuits.

●Electrical characteristics curves

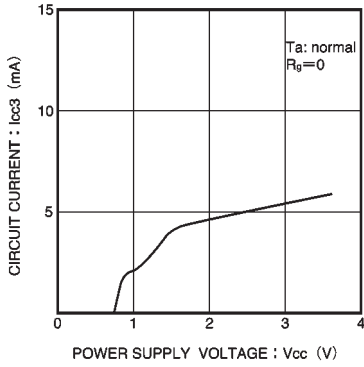

Fig. 7 Quiescent current vs. power supply voltage

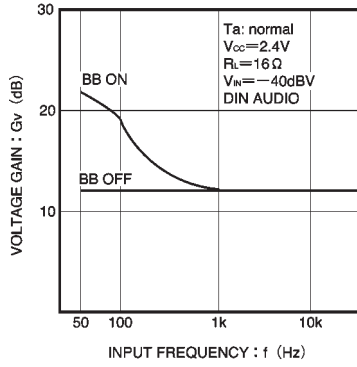

Fig. 8 Voltage gain vs. frequency

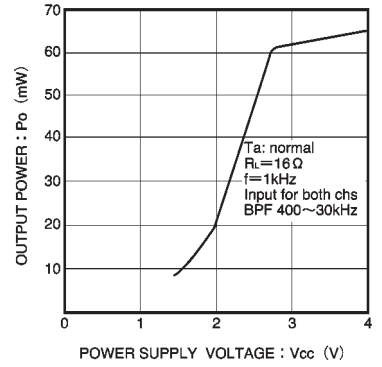

Fig. 9 Rated output power vs. power supply voltage

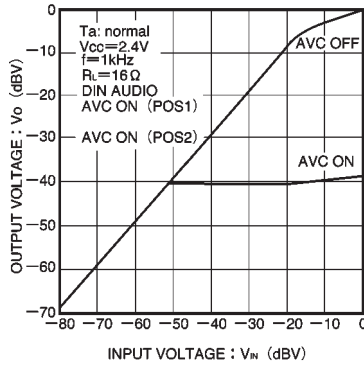

Fig. 10 AVC characteristics

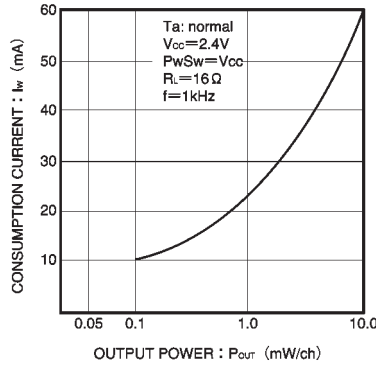
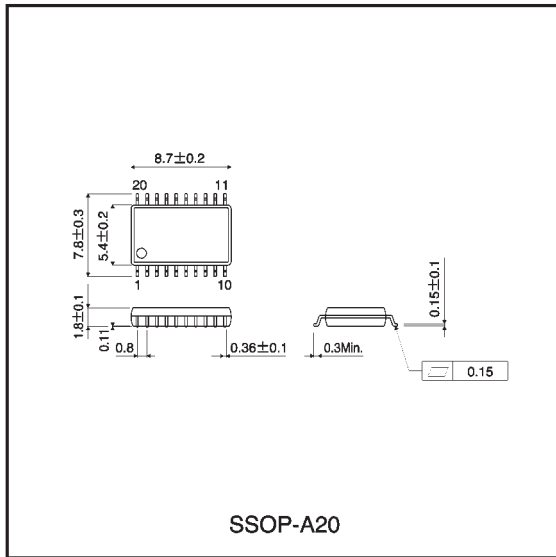

Fig. 11 Current dissipation vs. output power

● External dimensions (Units: mm)



Notes

- No technical content pages of this document may be reproduced in any form or transmitted by any means without prior permission of ROHM CO.,LTD.
- The contents described herein are subject to change without notice. The specifications for the product described in this document are for reference only. Upon actual use, therefore, please request that specifications to be separately delivered.
- Application circuit diagrams and circuit constants contained herein are shown as examples of standard use and operation. Please pay careful attention to the peripheral conditions when designing circuits and deciding upon circuit constants in the set.
- Any data, including, but not limited to application circuit diagrams information, described herein are intended only as illustrations of such devices and not as the specifications for such devices. ROHM CO.,LTD. disclaims any warranty that any use of such devices shall be free from infringement of any third party's intellectual property rights or other proprietary rights, and further, assumes no liability of whatsoever nature in the event of any such infringement, or arising from or connected with or related to the use of such devices.
- Upon the sale of any such devices, other than for buyer's right to use such devices itself, resell or otherwise dispose of the same, no express or implied right or license to practice or commercially exploit any intellectual property rights or other proprietary rights owned or controlled by
- ROHM CO., LTD. is granted to any such buyer.
- Products listed in this document use silicon as a basic material.
Products listed in this document are no antiradiation design.

The products listed in this document are designed to be used with ordinary electronic equipment or devices (such as audio visual equipment, office-automation equipment, communications devices, electrical appliances and electronic toys).

Should you intend to use these products with equipment or devices which require an extremely high level of reliability and the malfunction of which would directly endanger human life (such as medical instruments, transportation equipment, aerospace machinery, nuclear-reactor controllers, fuel controllers and other safety devices), please be sure to consult with our sales representative in advance.

About Export Control Order in Japan

Products described herein are the objects of controlled goods in Annex 1 (Item 16) of Export Trade Control Order in Japan.

In case of export from Japan, please confirm if it applies to "objective" criteria or an "informed" (by MITI clause) on the basis of "catch all controls for Non-Proliferation of Weapons of Mass Destruction.