

# DATA SHEET

## **TDA8359J**

Full bridge vertical deflection output  
circuit in LVDMOS

Product specification  
Supersedes data of 13 March 2000  
Filed under Integrated Circuits, IC02

2002 Jan 21

## Full bridge vertical deflection output circuit in LVDMOS

## TDA8359J

### FEATURES

- Few external components required
- High efficiency fully DC-coupled vertical bridge output circuit
- Vertical flyback switch with short rise and fall times
- Built-in guard circuit
- Thermal protection circuit
- Improved EMC performance due to differential inputs.

### GENERAL DESCRIPTION

The TDA8359J is a power circuit for use in 90° and 110° colour deflection systems for 25 to 200 Hz field frequencies, and for 4 : 3 and 16 : 9 picture tubes. The IC contains a vertical deflection output circuit, operating as a high efficiency class G system. The full bridge output circuit allows DC coupling of the deflection coil in combination with single positive supply voltages.

The IC is constructed in a Low Voltage DMOS (LVDMOS) process that combines bipolar, CMOS and DMOS devices. DMOS transistors are used in the output stage because of absence of second breakdown.

### QUICK REFERENCE DATA

SYMBOL	PARAMETER	CONDITIONS	MIN.	TYP.	MAX.	UNIT
<b>Supplies</b>						
$V_P$	supply voltage		7.5	12	18	V
$V_{FB}$	flyback supply voltage		$2 \times V_P$	45	66	V
$I_{q(P)(av)}$	average quiescent supply current	during scan	–	10	15	mA
$I_{q(FB)(av)}$	average quiescent flyback supply current	during scan	–	–	10	mA
$P_{tot}$	total power dissipation		–	–	10	W
<b>Inputs and outputs</b>						
$V_{i(p-p)}$	input voltage (peak-to-peak value)		–	1000	1500	mV
$I_{o(p-p)}$	output current (peak-to-peak value)		–	–	3.2	A
<b>Flyback switch</b>						
$I_{o(peak)}$	maximum (peak) output current	$t \leq 1.5$ ms	–	–	$\pm 1.8$	A
<b>Thermal data; in accordance with IEC 60747-1</b>						
$T_{stg}$	storage temperature		–55	–	+150	°C
$T_{amb}$	ambient temperature		–25	–	+85	°C
$T_j$	junction temperature		–	–	150	°C

### ORDERING INFORMATION

TYPE NUMBER	PACKAGE		
	NAME	DESCRIPTION	VERSION
TDA8359J	DBS9P	plastic DIL-bent-SIL power package; 9 leads (lead length 12/11 mm); exposed die pad	SOT523-1

Full bridge vertical deflection output circuit  
in LVDMOS

TDA8359J

BLOCK DIAGRAM

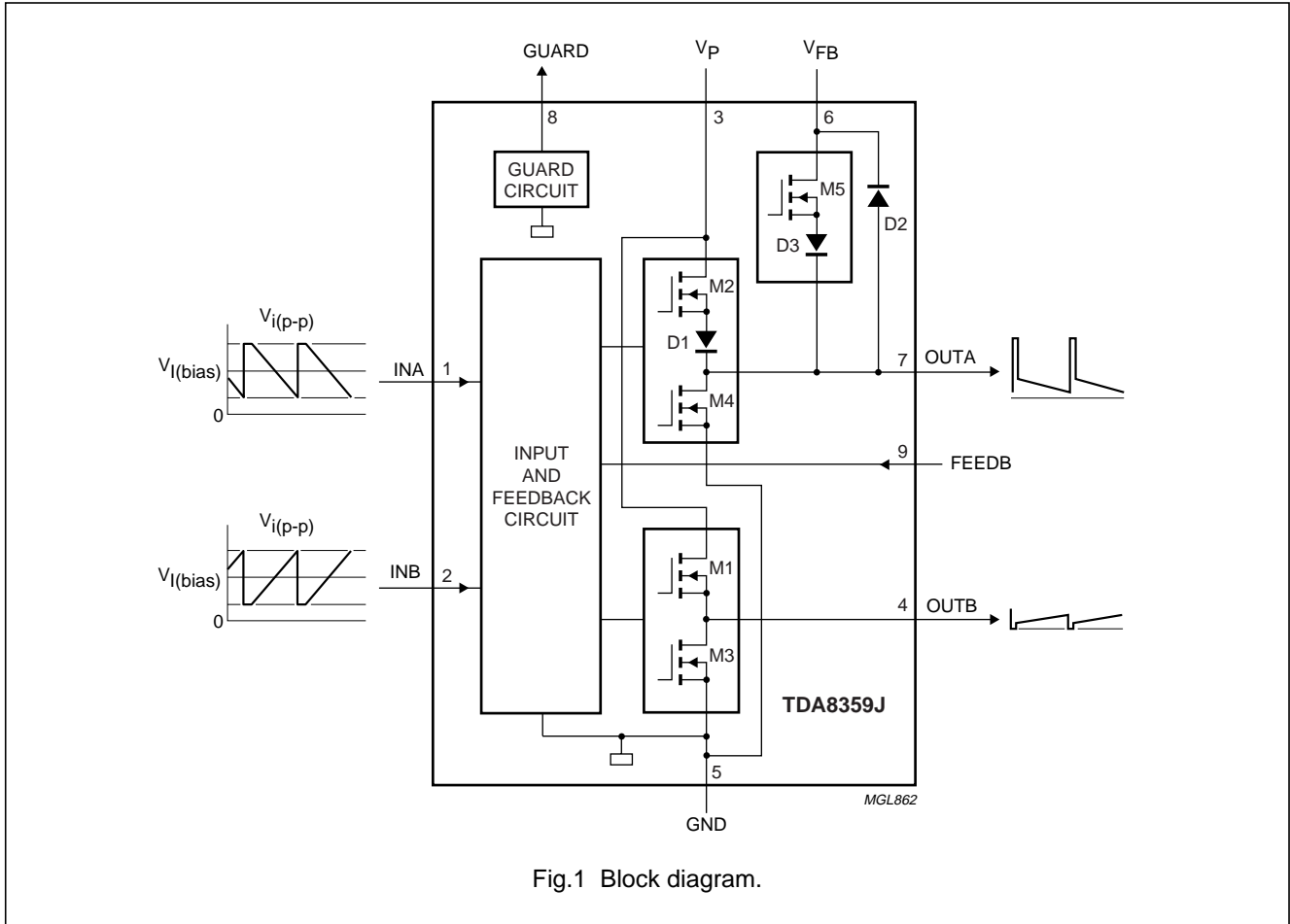

Fig.1 Block diagram.

PINNING

SYMBOL	PIN	DESCRIPTION
INA	1	input A
INB	2	input B
VP	3	supply voltage
OUTB	4	output B
GND	5	ground
VFB	6	flyback supply voltage
OUTA	7	output A
GUARD	8	guard output
FEEDB	9	feedback input

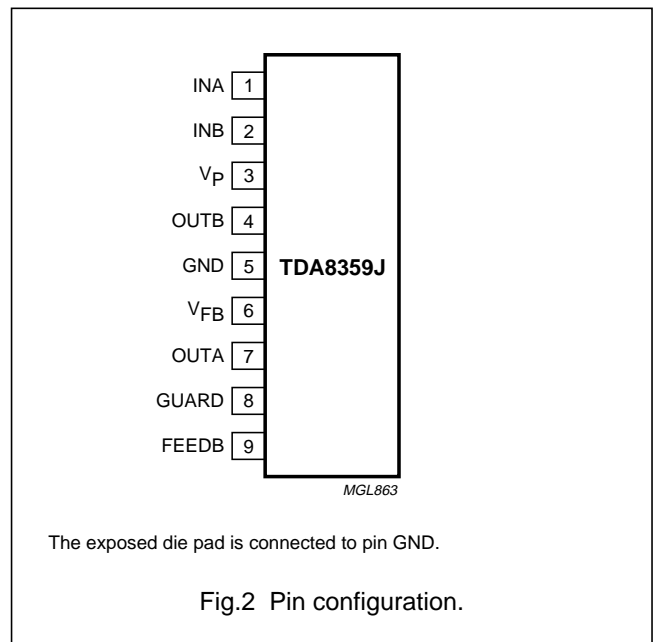

Fig.2 Pin configuration.

## Full bridge vertical deflection output circuit in LVDMOS

TDA8359J

### FUNCTIONAL DESCRIPTION

#### Vertical output stage

The vertical driver circuit has a bridge configuration. The deflection coil is connected between the complimentary driven output amplifiers. The differential input circuit is voltage driven. The input circuit is specially designed for direct connection to driver circuits delivering a differential signal but it is also suitable for single-ended applications. For processors with output currents, the currents are converted to voltages by the conversion resistors  $R_{CV1}$  and  $R_{CV2}$  (see Fig.5) connected to pins INA and INB. The differential input voltage is compared with the voltage across the measuring resistor  $R_M$ , providing feedback information. The voltage across  $R_M$  is proportional with the output current. The relationship between the differential input voltage and the output current is defined by:

$$V_{i(dif)(p-p)} = I_{o(p-p)} \times R_M$$

$$V_{i(dif)(p-p)} = V_{INA} - V_{INB}$$

The output current should not exceed 3.2 A (p-p) and is determined by the value of  $R_M$  and  $R_{CV}$ . The allowable input voltage range is 100 mV to 1.6 V for each input. The formula given does not include internal bondwire resistances. Depending on the values of  $R_M$  and the internal bondwire resistance (typical value of 50 m $\Omega$ ) the actual value of the current in the deflection coil will be approximately 5% lower than calculated.

#### Flyback supply

The flyback voltage is determined by the flyback supply voltage  $V_{FB}$ . The principle of two supply voltages (class G) allows to use an optimum supply voltage  $V_P$  for scan and an optimum flyback supply voltage  $V_{FB}$  for flyback, thus very high efficiency is achieved. The available flyback output voltage across the coil is almost equal to  $V_{FB}$ , due to the absence of a coupling capacitor which is not required in a bridge configuration. The very short rise and fall times of the flyback switch are determined mainly by the slew rate value of more than 300 V/ $\mu$ s.

#### Protection

The output circuit contains protection circuits for:

- Too high die temperature
- Overvoltage of output A.

#### Guard circuit

A guard circuit with output pin GUARD is provided.

The guard circuit generates a HIGH-level during the flyback period. The guard circuit is also activated for one of the following conditions:

- During thermal protection ( $T_j = 170$  °C)
- During an open-loop condition.

The guard signal can be used for blanking the picture tube and signalling fault conditions. The vertical synchronization pulses of the guard signal can be used by an On Screen Display (OSD) microcontroller.

#### Damping resistor compensation

HF loop stability is achieved by connecting a damping resistor  $R_{D1}$  across the deflection coil. The current values in  $R_{D1}$  during scan and flyback are significantly different. Both the resistor current and the deflection coil current flow into measuring resistor  $R_M$ , resulting in a too low deflection coil current at the start of the scan.

The difference in the damping resistor current values during scan and flyback have to be externally compensated in order to achieve a short settling time. For that purpose a compensation resistor  $R_{CMP}$  in series with a zener diode is connected between pins OUTA and INA (see Fig.4). The zener diode voltage value should be equal to  $V_P$ . The value of  $R_{CMP}$  is calculated by:

$$R_{CMP} = \frac{(V_{FB} - V_{loss(FB)} - V_Z) \times R_{D1} \times R_{CV1}}{(V_{FB} - V_{loss(FB)} - I_{coil(peak)} \times R_{coil}) \times R_M}$$

where:

- $V_{loss(FB)}$  is the voltage loss between pins  $V_{FB}$  and OUTA at flyback
- $R_{coil}$  is the deflection coil resistance
- $V_Z$  is the voltage of zener diode D4.

## Full bridge vertical deflection output circuit in LVDMOS

TDA8359J

### LIMITING VALUES

In accordance with the Absolute Maximum Rating System (IEC 60134).

SYMBOL	PARAMETER	CONDITIONS	MIN.	MAX.	UNIT
$V_P$	supply voltage		–	18	V
$V_{FB}$	flyback supply voltage		–	68	V
$V_n$	DC voltage pin OUTA pin OUTB pins INA, INB, GUARD and FEEDB	note 1	– – –0.5	68 $V_P$ $V_P$	V V V
$I_n$	DC current pins OUTA and OUTB pins OUTA and OUTB pins INA, INB, GUARD and FEEDB	during scan (p-p) at flyback (peak); $t \leq 1.5$ ms	– – –20	3.2 $\pm 1.8$ +20	A A mA
$I_{lu}$	latch-up current	current into any pin; pin voltage is $1.5 \times V_P$ ; note 2	–	+200	mA
		current out of any pin; pin voltage is $-1.5 \times V_P$ ; note 2	–200	–	mA
$V_{es}$	electrostatic handling voltage	machine model; note 3	–500	+500	V
		human body model; note 4	–5000	+5000	V
$P_{tot}$	total power dissipation		–	10	W
$T_{stg}$	storage temperature		–55	+150	°C
$T_{amb}$	ambient temperature		–25	+85	°C
$T_j$	junction temperature	note 5	–	150	°C

### Notes

- When the voltage at pin OUTA supersedes 70 V the circuit will limit the voltage.
- At  $T_{j(max)}$ .
- Equivalent to 200 pF capacitance discharge through a 0  $\Omega$  resistor.
- Equivalent to 100 pF capacitance discharge through a 1.5 k $\Omega$  resistor.
- Internally limited by thermal protection at  $T_j = 170$  °C.

### THERMAL CHARACTERISTICS

In accordance with IEC 60747-1.

SYMBOL	PARAMETER	CONDITIONS	MAX.	UNIT
$R_{th(j-c)}$	thermal resistance from junction to case		3	K/W
$R_{th(j-a)}$	thermal resistance from junction to ambient	in free air	65	K/W

## Full bridge vertical deflection output circuit in LVDMOS

TDA8359J

### CHARACTERISTICS

$V_P = 12\text{ V}$ ;  $V_{FB} = 45\text{ V}$ ;  $f_{\text{vert}} = 50\text{ Hz}$ ;  $V_{I(\text{bias})} = 880\text{ mV}$ ;  $T_{\text{amb}} = 25\text{ °C}$ ; measured in test circuit of Fig.3; unless otherwise specified.

SYMBOL	PARAMETER	CONDITIONS	MIN.	TYP.	MAX.	UNIT
<b>Supplies</b>						
$V_P$	operating supply voltage		7.5	12	18	V
$V_{FB}$	flyback supply voltage	note 1	$2 \times V_P$	45	66	V
$I_{q(P)(\text{av})}$	average quiescent supply current	during scan	–	10	15	mA
$I_{q(P)}$	quiescent supply current	no signal; no load	–	45	75	mA
$I_{q(FB)(\text{av})}$	average quiescent flyback supply current	during scan	–	–	10	mA
<b>Inputs A and B</b>						
$V_{i(\text{p-p})}$	input voltage (peak-to-peak value)	note 2	–	1000	1500	mV
$V_{I(\text{bias})}$	input bias voltage	note 2	100	880	1600	mV
$I_{I(\text{bias})}$	input bias current	source	–	25	35	$\mu\text{A}$
<b>Outputs A and B</b>						
$V_{\text{loss}(1)}$	voltage loss first scan part	note 3 $I_o = 1.1\text{ A}$ $I_o = 1.6\text{ A}$	– –	– –	4.5 6.6	V V
$V_{\text{loss}(2)}$	voltage loss second scan part	note 4 $I_o = -1.1\text{ A}$ $I_o = -1.6\text{ A}$	– –	– –	3.3 4.8	V V
$I_{o(\text{p-p})}$	output current (peak-to-peak value)		–	–	3.2	A
LE	linearity error	$I_{o(\text{p-p})} = 3.2\text{ A}$ ; notes 5 and 6 adjacent blocks non adjacent blocks	– –	1 1	2 3	% %
$V_{\text{offset}}$	offset voltage	across $R_M$ ; $V_{i(\text{dif})} = 0\text{ V}$ $V_{I(\text{bias})} = 200\text{ mV}$ $V_{I(\text{bias})} = 1\text{ V}$	– –	– –	$\pm 15$ $\pm 20$	mV mV
$\Delta V_{\text{offset}(T)}$	offset voltage variation with temperature	across $R_M$ ; $V_{i(\text{dif})} = 0\text{ V}$	–	–	40	$\mu\text{V/K}$
$V_O$	DC output voltage	$V_{i(\text{dif})} = 0\text{ V}$	–	$0.5 \times V_P$	–	V
$G_{V(\text{ol})}$	open-loop voltage gain	notes 7 and 8	–	60	–	dB
$f_{-3\text{dB}(h)}$	high –3 dB cut-off frequency	open-loop	–	1	–	kHz
$G_V$	voltage gain	note 9	–	1	–	
$\Delta G_{V(T)}$	voltage gain variation with the temperature		–	–	$10^{-4}$	$\text{K}^{-1}$
PSRR	power supply rejection ratio	note 10	80	90	–	dB

## Full bridge vertical deflection output circuit in LVDMOS

TDA8359J

SYMBOL	PARAMETER	CONDITIONS	MIN.	TYP.	MAX.	UNIT
<b>Flyback switch</b>						
$I_{O(\text{peak})}$	maximum (peak) output current	$t \leq 1.5 \text{ ms}$	–	–	$\pm 1.8$	A
$V_{\text{loss}(\text{FB})}$	voltage loss at flyback	note 11				
		$I_o = 1.1 \text{ A}$	–	7.5	8.5	V
		$I_o = 1.6 \text{ A}$	–	8	9	V
<b>Guard circuit</b>						
$V_{O(\text{grd})}$	guard output voltage	$I_{O(\text{grd})} = 100 \mu\text{A}$	5	6	7	V
$V_{O(\text{grd})(\text{max})}$	allowable guard voltage	maximum leakage current $I_{L(\text{max})} = 10 \mu\text{A}$	–	–	18	V
$I_{O(\text{grd})}$	output current	$V_{O(\text{grd})} = 0 \text{ V}$ ; not active	–	–	10	$\mu\text{A}$
		$V_{O(\text{grd})} = 4.5 \text{ V}$ ; active	1	–	2.5	mA

### Notes

- To limit  $V_{\text{OUTA}}$  to 68 V,  $V_{\text{FB}}$  must be 66 V due to the voltage drop of the internal flyback diode between pins OUTA and  $V_{\text{FB}}$  at the first part of the flyback.
- Allowable input range for both inputs:  $V_{I(\text{bias})} + V_i < 1600 \text{ mV}$  and  $V_{I(\text{bias})} - V_i > 100 \text{ mV}$ .
- This value specifies the sum of the voltage losses of the internal current paths between pins  $V_P$  and OUTA, and between pins OUTB and GND. Specified for  $T_j = 125 \text{ }^\circ\text{C}$ . The temperature coefficient for  $V_{\text{loss}(1)}$  is a positive value.
- This value specifies the sum of the voltage losses of the internal current paths between pins  $V_P$  and OUTB, and between pins OUTA and GND. Specified for  $T_j = 125 \text{ }^\circ\text{C}$ . The temperature coefficient for  $V_{\text{loss}(2)}$  is a positive value.
- The linearity error is measured for a linear input signal without S-correction and is based on the 'on screen' measurement principle. This method is defined as follows. The output signal is divided in 22 successive equal time parts. The 1st and 22nd parts are ignored, and the remaining 20 parts form 10 successive blocks k. A block consists of two successive parts. The voltage amplitudes are measured across  $R_M$ , starting at  $k = 1$  and ending at  $k = 10$ , where  $V_k$  and  $V_{k+1}$  are the measured voltages of two successive blocks.  $V_{\text{min}}$ ,  $V_{\text{max}}$  and  $V_{\text{avg}}$  are the minimum, maximum and average voltages respectively. The linearity errors are defined as:

$$\text{a) } LE = \frac{V_k - V_{k+1}}{V_{\text{avg}}} \times 100 \% \text{ (adjacent blocks)}$$

$$\text{b) } LE = \frac{V_{\text{max}} - V_{\text{min}}}{V_{\text{avg}}} \times 100 \% \text{ (non adjacent blocks)}$$

- The linearity errors are specified for a minimum input voltage of 300 mV (p-p). Lower input voltages lead to voltage dependent S-distortion in the input stage.

$$7. \quad G_{V(\text{ol})} = \frac{V_{\text{OUTA}} - V_{\text{OUTB}}}{V_{\text{FEEDB}} - V_{\text{OUTB}}}$$

- Pin FEEDB not connected.

$$9. \quad G_V = \frac{V_{\text{FEEDB}} - V_{\text{OUTB}}}{V_{\text{INA}} - V_{\text{INB}}}$$

- $V_{P(\text{ripple})} = 500 \text{ mV}$  (RMS value);  $50 \text{ Hz} < f_{P(\text{ripple})} < 1 \text{ kHz}$ ; measured across  $R_M$ .

- This value specifies the internal voltage loss of the current path between pins  $V_{\text{FB}}$  and OUTA.

Full bridge vertical deflection output circuit  
in LVDMOS

TDA8359J

APPLICATION INFORMATION

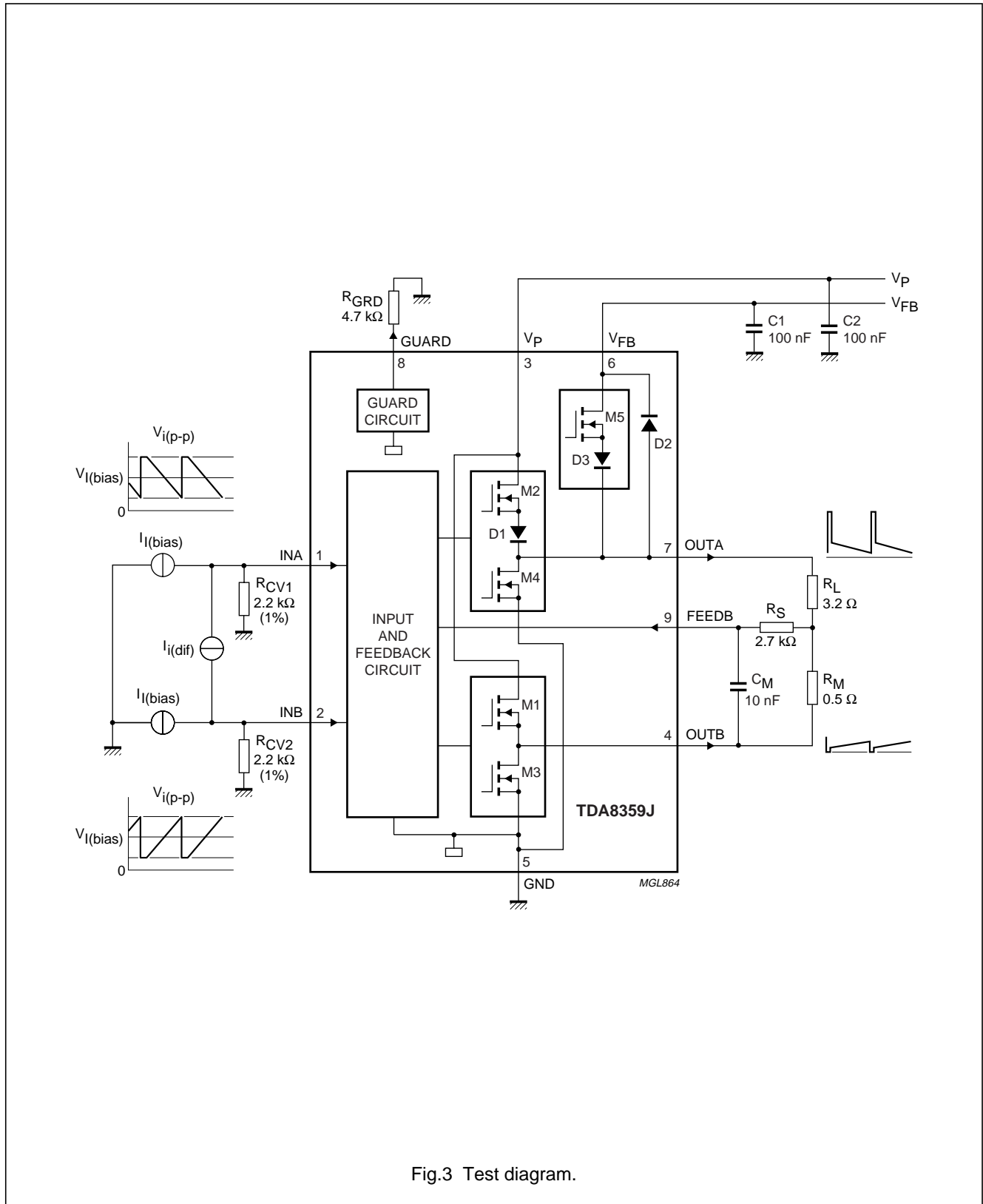
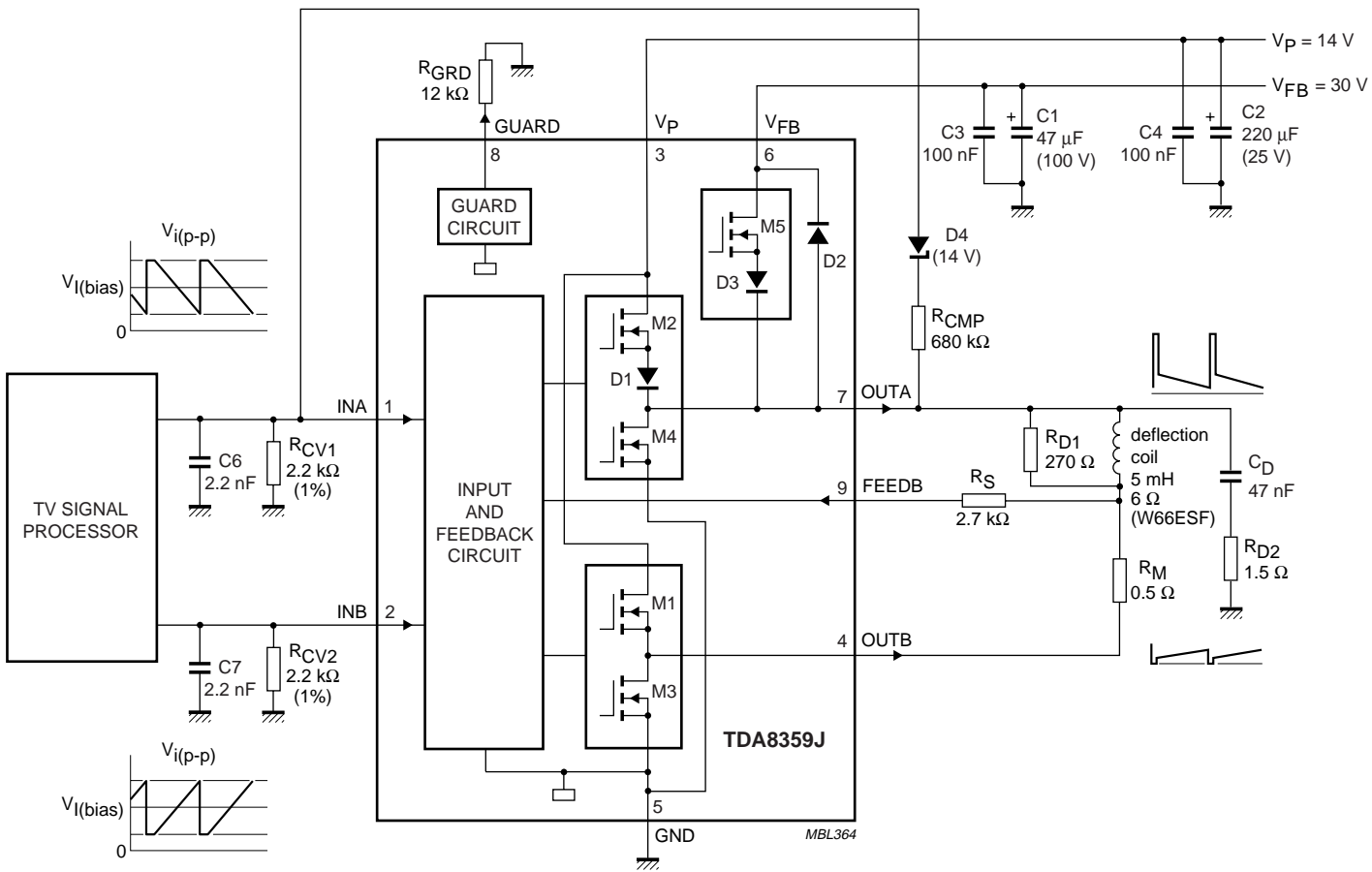

Fig.3 Test diagram.



Full bridge vertical deflection output circuit  
in LVDMOS

TDA8359J



$f_{\text{vert}} = 50 \text{ Hz}$ ;  $t_{\text{FB}} = 640 \mu\text{s}$ ;  $I_{\text{I(bias)}} = 400 \mu\text{A}$ ;  $I_{\text{I(p-p)}} = 290 \mu\text{A}$ ;  $I_{\text{O(p-p)}} = 2.4 \text{ A}$ .

Fig.4 Application diagram.

# Full bridge vertical deflection output circuit in LVDMOS

TDA8359J

### R<sub>M</sub> calculation

Most Philips brand TV signal processors have outputs in the form of current. This current has to be converted to a voltage by using resistors at the input of the TDA8359J (R<sub>CV1</sub> and R<sub>CV2</sub>). The differential voltage across these resistors can be calculated by:

$$V_{i(dif)(p-p)} = I_{i1(p-p)} \times R_{CV1} - (-I_{i2(p-p)}) \times R_{CV2}$$

For calculating the measuring resistor R<sub>M</sub>, use the differential input voltage (V<sub>i(dif)(p-p)</sub>). This voltage can also be measured between pins INA and INB (see Fig.5). The calculation for R<sub>M</sub> is:

$$R_M = \frac{V_{i(dif)(p-p)}}{I_{o(p-p)}}$$

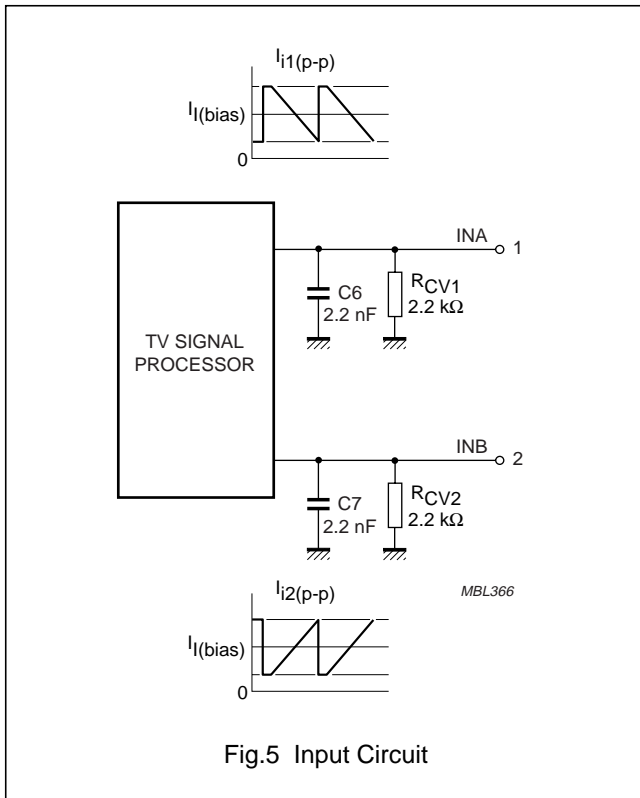

Fig.5 Input Circuit

### EXAMPLE

Measured or given values: I<sub>I(bias)</sub> = 400 μA; I<sub>i1(p-p)</sub> = I<sub>i2(p-p)</sub> = 290 μA.

The differential input voltage will be:

$$V_{i(dif)(p-p)} = 290\mu A \times 2.2k\Omega - (-290\mu A \times 2.2k\Omega) = 1.27V$$

### Supply voltage calculation

For calculating the minimum required supply voltage, several specific application parameter values have to be known. These parameters are the required maximum (peak) deflection coil current I<sub>coil(peak)</sub>, the coil impedance R<sub>coil</sub> and L<sub>coil</sub>, and the measuring resistance of R<sub>M</sub>. The required maximum (peak) deflection coil current should also include overscan.

The deflection coil resistance has to be multiplied by 1.2 in order to take account of hot conditions.

Chapter “Characteristics” supplies values for voltage losses of the vertical output stage. For the first part of the scan, the voltage loss is given by V<sub>loss(1)</sub>. For the second part of the scan, the voltage loss is given by V<sub>loss(2)</sub>.

The voltage drop across the deflection coil during scan is determined by the coil impedance. For the first part of the scan the inductive contribution and the ohmic contribution to the total coil voltage drop are of opposite sign, while for the second part of the scan the inductive part and the ohmic part have the same sign.

For the vertical frequency the maximum frequency occurring must be applied to the calculations.

The required power supply voltage V<sub>P</sub> for the first part of the scan is given by:

$$V_{P(1)} = I_{coil(peak)} \times (R_{coil} + R_M) - L_{coil} \times 2I_{coil(peak)} \times f_{vert(max)} + V_{loss(1)}$$

The required power supply voltage V<sub>P</sub> for the second part of the scan is given by:

$$V_{P(2)} = I_{coil(peak)} \times (R_{coil} + R_M) + L_{coil} \times 2I_{coil(peak)} \times f_{vert(max)} + V_{loss(2)}$$

The minimum required supply voltage V<sub>P</sub> shall be the highest of the two values V<sub>P(1)</sub> and V<sub>P(2)</sub>. Spread in supply voltage and component values also has to be taken into account.

# Full bridge vertical deflection output circuit in LVDMOS

TDA8359J

### Flyback supply voltage calculation

If the flyback time is known, the required flyback supply voltage can be calculated by the simplified formula:

$$V_{FB} = I_{coil(p-p)} \times \frac{R_{coil} + R_M}{1 - e^{-t_{FB}/x}}$$

where:

$$x = \frac{L_{coil}}{R_{coil} + R_M}$$

The flyback supply voltage calculated this way is approximately 5% to 10% higher than required.

### Calculation of the power dissipation of the vertical output stage

The IC total power dissipation is given by the formula:

$$P_{tot} = P_{sup} - P_L$$

The power to be supplied is given by the formula:

$$P_{sup} = V_P \times \frac{I_{coil(peak)}}{2} + V_P \times 0.015 [A] + 0.3 [W]$$

In this formula 0.3 [W] represents the average value of the losses in the flyback supply.

The average external load power dissipation in the deflection coil and the measuring resistor is given by the formula:

$$P_L = \frac{(I_{coil(peak)})^2}{3} \times (R_{coil} + R_M)$$

### Example

**Table 1** Application values

SYMBOL	VALUE	UNIT
$I_{coil(peak)}$	1.2	A
$I_{coil(p-p)}$	2.4	A
$L_{coil}$	5	mH
$R_{coil}$	6	$\Omega$
$R_M$	0.6	$\Omega$
$f_{vert}$	50	Hz
$t_{FB}$	640	$\mu s$

**Table 2** Calculated values

SYMBOL	VALUE	UNIT
$V_P$	14	V
$R_M + R_{coil} (hot)$	7.8	$\Omega$
$t_{vert}$	0.02	s
x	0.000641	
$V_{FB}$	30	V
$P_{sup}$	8.91	W
$P_L$	3.74	W
$P_{tot}$	5.17	W

### Heatsink calculation

The value of the heatsink can be calculated in a standard way with a method based on average temperatures. The required thermal resistance of the heatsink is determined by the maximum die temperature of 150 °C. **In general we recommend to design for an average die temperature not exceeding 130 °C.**

#### EXAMPLE

Measured or given values:  $P_{tot} = 6 W$ ;  $T_{amb(max)} = 40 °C$ ;  $T_j = 120 °C$ ;  $R_{th(j-c)} = 4 K/W$ ;  $R_{th(c-h)} = 2 K/W$ .

The required heatsink thermal resistance is given by:

$$R_{th(h-a)} = \frac{T_j - T_{amb}}{P_{tot}} - (R_{th(j-c)} + R_{th(c-h)})$$

When we use the values given we find:

$$R_{th(h-a)} = \frac{120 - 40}{6} - (4 + 2) = 7 K/W$$

The heatsink temperature will be:

$$T_h = T_{amb} + (R_{th(h-a)} \times P_{tot}) = 40 + (7 \times 6) = 82 °C$$

Full bridge vertical deflection output circuit  
in LVDMOS

TDA8359J

INTERNAL PIN CONFIGURATION

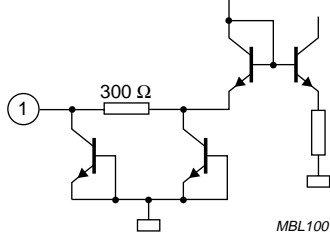
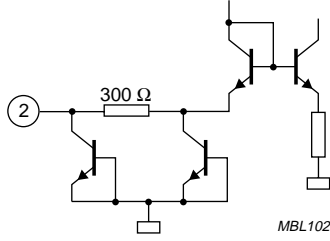
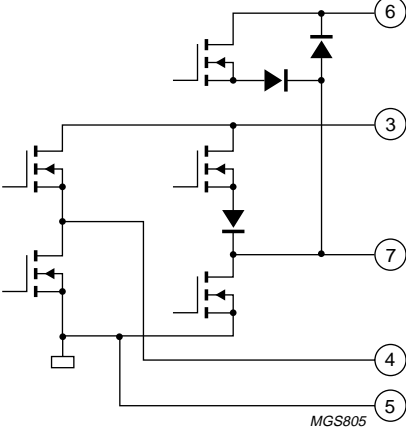
PIN	SYMBOL	EQUIVALENT CIRCUIT
1	INA	
2	INB	
3	$V_P$	
4	OUTB	
5	GND	
6	$V_{FB}$	
7	OUTA	

Full bridge vertical deflection output circuit  
in LVDMOS

TDA8359J

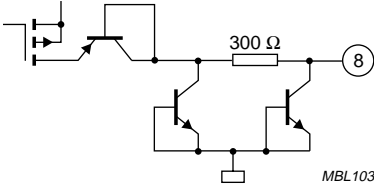
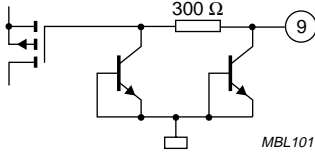
PIN	SYMBOL	EQUIVALENT CIRCUIT
8	GUARD	
9	FEEDB	

# Full bridge vertical deflection output circuit in LVDMOS

TDA8359J

## PACKAGE OUTLINE

DBS9P: plastic DIL-bent-SIL power package; 9 leads (lead length 12/11 mm); exposed die pad

SOT523-1

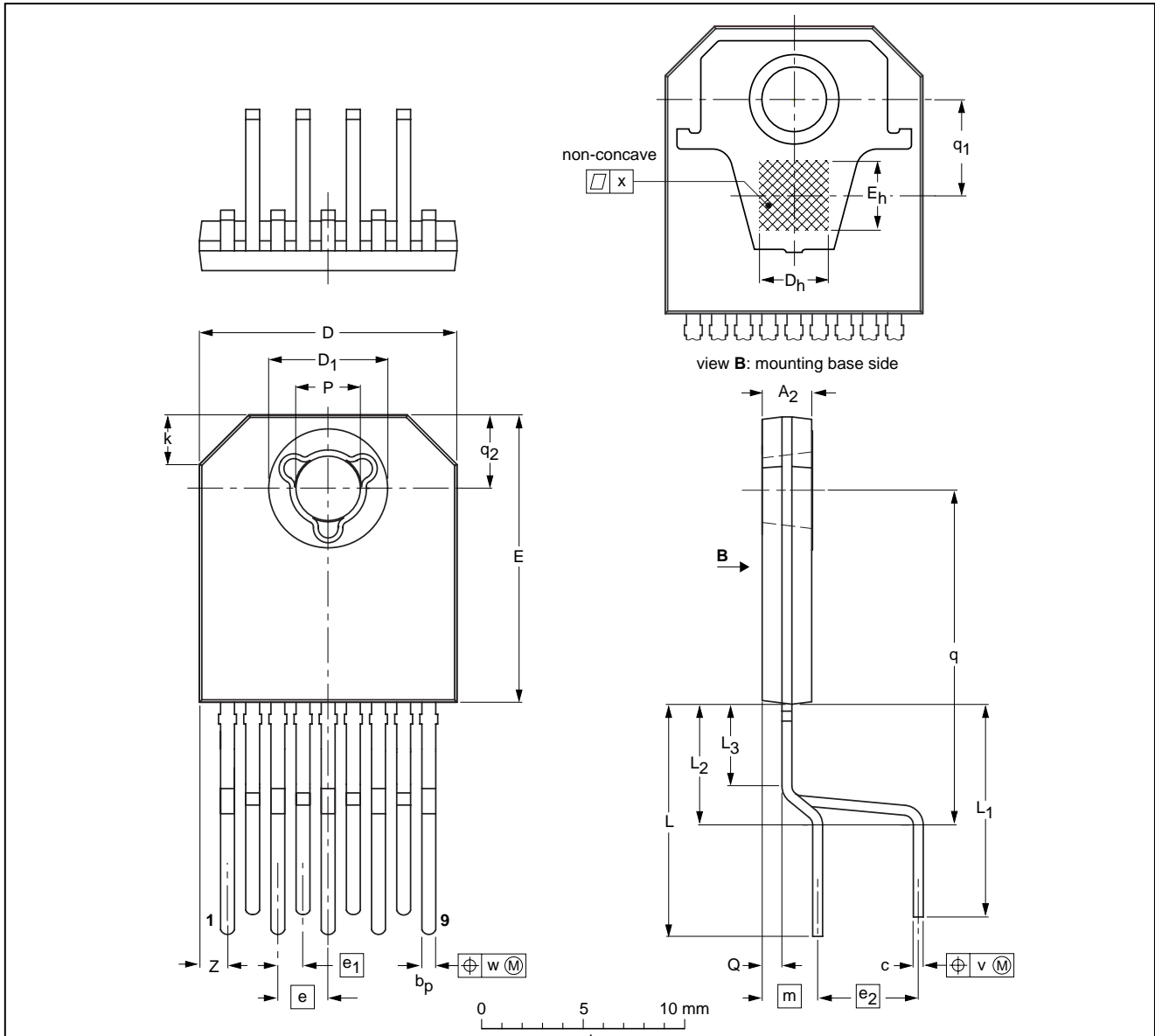

DIMENSIONS (mm are the original dimensions)

UNIT	A <sub>2</sub> <sup>(2)</sup>	b <sub>p</sub>	c	D <sup>(1)</sup>	D <sub>1</sub> <sup>(2)</sup>	D <sub>h</sub>	E <sup>(1)</sup>	E <sub>h</sub>	e	e <sub>1</sub>	e <sub>2</sub>	k	L	L <sub>1</sub>	L <sub>2</sub>	L <sub>3</sub>	m	P	Q	q	q <sub>1</sub>	q <sub>2</sub>	v	w	x	z <sup>(1)</sup>
mm	2.7 2.3	0.80 0.65	0.58 0.48	13.2 12.8	6.2 5.8	3.5	14.7 14.3	3.5	2.54	1.27	5.08	3.0 2.0	12.4 11.0	11.4 10.0	6.7 5.5	4.5 3.7	2.8	3.4 3.1	1.15 0.85	17.5 16.3	4.85	3.8 3.6	0.8	0.3	0.02	1.65 1.10

- Notes
1. Plastic or metal protrusions of 0.25 mm maximum per side are not included.
  2. Plastic surface within circle area D<sub>1</sub> may protrude 0.04 mm maximum.

OUTLINE VERSION	REFERENCES				EUROPEAN PROJECTION	ISSUE DATE
	IEC	JEDEC	EIAJ			
SOT523-1						98-11-12-00-07-03

## Full bridge vertical deflection output circuit in LVDMOS

TDA8359J

### SOLDERING

#### Introduction to soldering through-hole mount packages

This text gives a brief insight to wave, dip and manual soldering. A more in-depth account of soldering ICs can be found in our *"Data Handbook IC26; Integrated Circuit Packages"* (document order number 9398 652 90011).

Wave soldering is the preferred method for mounting of through-hole mount IC packages on a printed-circuit board.

#### Soldering by dipping or by solder wave

The maximum permissible temperature of the solder is 260 °C; solder at this temperature must not be in contact with the joints for more than 5 seconds.

The total contact time of successive solder waves must not exceed 5 seconds.

The device may be mounted up to the seating plane, but the temperature of the plastic body must not exceed the specified maximum storage temperature ( $T_{stg(max)}$ ). If the printed-circuit board has been pre-heated, forced cooling may be necessary immediately after soldering to keep the temperature within the permissible limit.

#### Manual soldering

Apply the soldering iron (24 V or less) to the lead(s) of the package, either below the seating plane or not more than 2 mm above it. If the temperature of the soldering iron bit is less than 300 °C it may remain in contact for up to 10 seconds. If the bit temperature is between 300 and 400 °C, contact may be up to 5 seconds.

#### Suitability of through-hole mount IC packages for dipping and wave soldering methods

PACKAGE	SOLDERING METHOD	
	DIPPING	WAVE
DBS, DIP, HDIP, SDIP, SIL	suitable	suitable <sup>(1)</sup>

#### Note

- For SDIP packages, the longitudinal axis must be parallel to the transport direction of the printed-circuit board.

## Full bridge vertical deflection output circuit in LVDMOS

TDA8359J

### DATA SHEET STATUS

DATA SHEET STATUS <sup>(1)</sup>	PRODUCT STATUS <sup>(2)</sup>	DEFINITIONS
Objective data	Development	This data sheet contains data from the objective specification for product development. Philips Semiconductors reserves the right to change the specification in any manner without notice.
Preliminary data	Qualification	This data sheet contains data from the preliminary specification. Supplementary data will be published at a later date. Philips Semiconductors reserves the right to change the specification without notice, in order to improve the design and supply the best possible product.
Product data	Production	This data sheet contains data from the product specification. Philips Semiconductors reserves the right to make changes at any time in order to improve the design, manufacturing and supply. Changes will be communicated according to the Customer Product/Process Change Notification (CPCN) procedure SNW-SQ-650A.

### Notes

1. Please consult the most recently issued data sheet before initiating or completing a design.
2. The product status of the device(s) described in this data sheet may have changed since this data sheet was published. The latest information is available on the Internet at URL <http://www.semiconductors.philips.com>.

### DEFINITIONS

**Short-form specification** — The data in a short-form specification is extracted from a full data sheet with the same type number and title. For detailed information see the relevant data sheet or data handbook.

**Limiting values definition** — Limiting values given are in accordance with the Absolute Maximum Rating System (IEC 60134). Stress above one or more of the limiting values may cause permanent damage to the device. These are stress ratings only and operation of the device at these or at any other conditions above those given in the Characteristics sections of the specification is not implied. Exposure to limiting values for extended periods may affect device reliability.

**Application information** — Applications that are described herein for any of these products are for illustrative purposes only. Philips Semiconductors make no representation or warranty that such applications will be suitable for the specified use without further testing or modification.

### DISCLAIMERS

**Life support applications** — These products are not designed for use in life support appliances, devices, or systems where malfunction of these products can reasonably be expected to result in personal injury. Philips Semiconductors customers using or selling these products for use in such applications do so at their own risk and agree to fully indemnify Philips Semiconductors for any damages resulting from such application.

**Right to make changes** — Philips Semiconductors reserves the right to make changes, without notice, in the products, including circuits, standard cells, and/or software, described or contained herein in order to improve design and/or performance. Philips Semiconductors assumes no responsibility or liability for the use of any of these products, conveys no licence or title under any patent, copyright, or mask work right to these products, and makes no representations or warranties that these products are free from patent, copyright, or mask work right infringement, unless otherwise specified.



Full bridge vertical deflection output circuit  
in LVDMOS

TDA8359J

---

**NOTES**

---

Full bridge vertical deflection output circuit  
in LVDMOS

---

TDA8359J

**NOTES**

---

Full bridge vertical deflection output circuit  
in LVDMOS

---

TDA8359J

**NOTES**

# ***Philips Semiconductors – a worldwide company***

## **Contact information**

For additional information please visit <http://www.semiconductors.philips.com>. Fax: +31 40 27 24825

For sales offices addresses send e-mail to: [sales.addresses@www.semiconductors.philips.com](mailto:sales.addresses@www.semiconductors.philips.com).

© Koninklijke Philips Electronics N.V. 2002

SCA74

All rights are reserved. Reproduction in whole or in part is prohibited without the prior written consent of the copyright owner.

The information presented in this document does not form part of any quotation or contract, is believed to be accurate and reliable and may be changed without notice. No liability will be accepted by the publisher for any consequence of its use. Publication thereof does not convey nor imply any license under patent- or other industrial or intellectual property rights.

Printed in The Netherlands

753504/25/02/pp20

Date of release: 2002 Jan 21

Document order number: 9397 750 08868

*Let's make things better.*

**Philips  
Semiconductors**



**PHILIPS**