

TOSHIBA BIPOLAR LINEAR INTEGRATED CIRCUIT SILICON MONOLITHIC

TA2068N

SYSTEM PREAMPLIFIER FOR SINGLE CASSETTE DECK

The TA2068N is system preamplifier IC for single deck radio-cassette tape player.

This IC have built-in function for single cassette deck and mixing amp for KARAOKE and Function switch for source selector.

FEATURES

- Dual Channel
- Built-in EQ Amp, REC Amp, Monitor Amp, Mic (Mixing) Amp
- Mic Amp is suitable for both inner mic and mixing mic.
- Built-in source selector switch ; RADIO-IN / TAPE-IN / AUX-IN
- 6-operation mode are available for INNER MIC set and MIXING MIC set.

<Inner MIC set>

- 1) TAPE PLAY-BACK
- 2) LINE-IN PLAY
- 3) RADIO PLAY
- 4) MIC RECORDING without MONITOR
- 5) LINE-IN RECORDING AND PLAY
- 6) RADIO RECORDING AND PLAY

<Mixing MIC set>

- 1) TAPE PLAY-BACK with MIC MIXING
- 2) LINE-IN PLAY with MIC MIXING
- 3) RADIO PLAY with MIC MIXING
- 4) MIC RECORDING with MONITOR
- 5) LINE-IN RECORDING AND PLAY with MIC MIXING
- 6) RADIO RECORDING AND PLAY with MIC MIXING

- Operating Supply Voltage Range
: $V_{CC}(\text{opr}) = 4.0 \sim 9.0\text{V}$ ($T_a = 25^\circ\text{C}$)

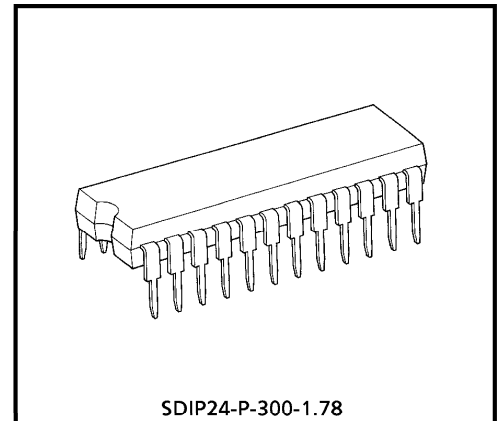

SDIP24-P-300-1.78

Weight : 1.2g (Typ.)

BLOCK DIAGRAM

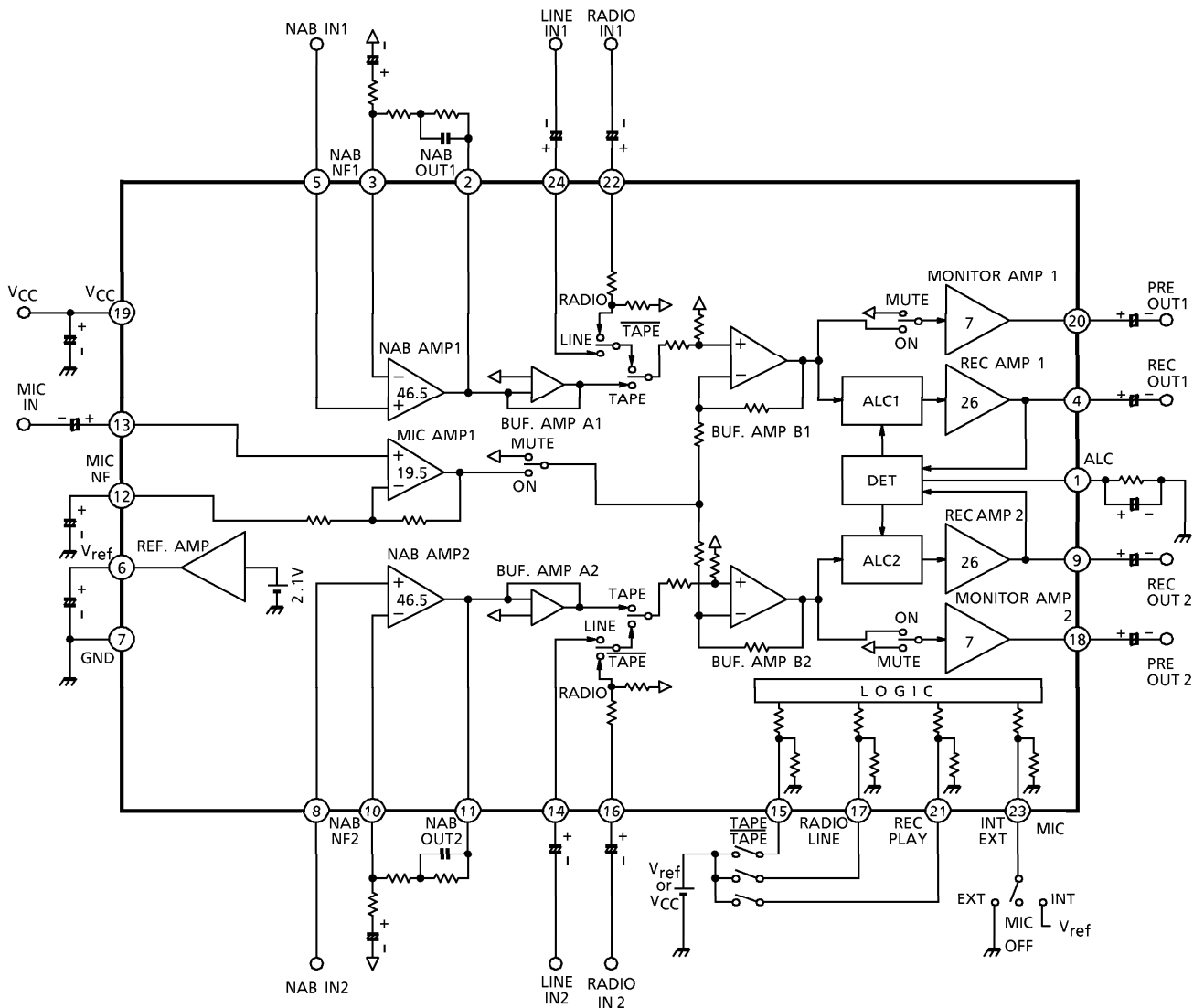

TERMINAL EXPLANATION

TERMINAL No.	SYMBOL	FUNCTION	EQUIVALENT CIRCUIT
1	ALC	Automatic level Control time constant terminal	
2 / 11	NAB OUT	Playback Amp output	
3 / 10	NAB NF	Playback Amp NF	
4 / 9	REC OUT	Recording Amp output	

TERMINAL No.	SYMBOL	FUNCTION	EQUIVALENT CIRCUIT
5 / 8	NAB IN	Playback Amp input	
6	V _{ref}	Reference voltage	
7	GND	GND terminal	—
12	MIC NF	MIC Amp NF	
16 / 22	RADIO IN	Radio input terminal	

TERMINAL No.	SYMBOL	FUNCTION	EQUIVALENT CIRCUIT
18 / 20	PRE OUT	MONITOR Amp output	
13	MIC IN	MIC Amp input	
14 / 24	LINE IN	Line input	
15	TAPE / $\overline{\text{TAPE}}$ SW	TAPE / EXTERNAL INPUT function SW	
17	LINE / RADIO SW	LINE / RADIO INPUT function SW	
21	REC / PLAY SW	PLAYBACK / RECORDING function SW	
23	INT / MIC OFF / EXT	INTERNAL MIC / MIC OFF / EXTERNAL MIC function SW	

SWITCH MODE EXPLANATION

FUNCTION			SWITCH MODE COMBINATION				INPUT	INPUT RESISTANCE R _g	OUTPUT AMPLIFIER
			SW ₄	SW ₃	SW ₂	SW ₁			
RADIO Mode	Play-back	(*) W.O V _{no} , R.R.	L/O	O/H	H	O	RADIO	—	MONITOR
		V _{no11}	O	O/H	H	O	—	RADIO	MONITOR
		V _{no12}	L	O/H	H	O	—	RADIO / MIC	MONITOR
		R.R.11	O	O/H	H	O	—	RADIO	MONITOR
	REC	R.R.12	L	O/H	H	O	—	RADIO / MIC	MONITOR
		(*) W.O V _{no} , R.R.	L/O	H	H	O	RADIO	—	REC
		V _{no21}	O	H	H	O	—	RADIO	REC
		V _{no22}	L	H	H	O	—	RADIO / MIC	REC
LINE Mode	Play-back	R.R.21	O	H	H	O	—	RADIO	REC
		R.R.22	L	H	H	O	—	RADIO / MIC	REC
		(*) W.O V _{no} , R.R.	L/O	O/H	O	O	LINE	—	MONITOR
		V _{no31}	O	O/H	O	O	—	LINE	MONITOR
	REC	V _{no32}	L	O/H	O	O	—	LINE / MIC	MONITOR
		R.R.31	O	O/H	O	O	—	LINE	MONITOR
		R.R.32	L	O/H	O	O	—	LINE / MIC	MONITOR
		(*) W.O V _{no} , R.R.	L/O	H	O	O	LINE	—	REC
TAPES Mode	Play-back	V _{no41}	O	H	O	O	—	LINE	REC
		V _{no42}	L	H	O	O	—	LINE / MIC	REC
		R.R.41	O	H	O	O	—	LINE	REC
		R.R.42	L	H	O	O	—	LINE / MIC	REC
		(*) W.O V _{no} , R.R.	L/O	O	O/H	H	TAPE	—	MONITOR
MIC Mode	Play-back	V _{no51}	O	O	O/H	H	—	TAPE	MONITOR
		V _{no52}	L	O	O/H	H	—	TAPE / MIC	MONITOR
		R.R.51	O	O	O/H	H	—	TAPE	MONITOR
		R.R.52	L	O	O/H	H	—	TAPE / MIC	MONITOR
	REC	(*) W.O V _{no} , R.R.	L	H	O/H	H	MIC	—	MONITOR
V _{no6}		L	H	O/H	H	—	MIC	MONITOR	
R.R.61		O	H	O/H	H	—	MIC	MONITOR	
REC	R.R.62	L	H	O/H	H	—	MIC	MONITOR	
	(*) W.O V _{no} , R.R.	L/O	H	O/H	H	MIC	—	REC	
	V _{no7}	L/O	H	O/H	H	—	MIC	REC	
		R.R.7	L/O	H	O/H	H	—	MIC	REC

L : GND
O : OPEN
H : V_{CC}

(*) W.O = WITHOUT

OPERATION MODE BY EXTERNAL SWITCH (1/2)

SW POSITION	MIC MODE G : EXT MIC O : MIC OFF H : INT MIC	V _{ref} INTERNAL MIC MODE				GND EXTERNAL MIC MODE			
		OPEN PLAY BACK MODE		VCC RECORDING MODE		OPEN PLAY BACK MODE		VCC RECORDING MODE	
REC/ PLAY	SW3 (21) O : PLAY H : REC	VCC	OPEN	VCC	OPEN	VCC	OPEN	VCC	OPEN
		VCC	OPEN	VCC	OPEN	VCC	OPEN	VCC	OPEN
SOURCE SELECT	SW2 (15) O : TAPE H : TAPE	VCC	OPEN	VCC	OPEN	VCC	OPEN	VCC	OPEN
		VCC	OPEN	VCC	OPEN	VCC	OPEN	VCC	OPEN
OPERATION MODE	SW1 (17) O : LINE H : RADIO	TAPE	LINE	MIC	RADIO	TAPE	LINE	MIC	RADIO
		○	○	○	○	○	○	○	○
INTERNAL OPERATION	INPUT/SOURCE	TAPE	LINE	MIC	RADIO	TAPE	LINE	MIC	RADIO
	MONITOR OUT	○	○	○	○	○	○	○	○
	REC OUT	○	○	○	○	○	○	○	○
	NAB AMP	ON	ON	OFF	OFF	ON	ON	OFF	OFF
	BUFFER AMP A	OFF	OFF	ON	ON	OFF	OFF	ON	ON
	LINE/RADIO SW	LINE	RADIO	LINE	RADIO	LINE	RADIO	LINE	RADIO
	TAPE/TAPE SW	TAPE	TAPE	TAPE	TAPE	TAPE	TAPE	TAPE	TAPE
	MIC AMP	MUTE	MUTE	ON	MUTE	ON	ON	ON	ON
	BUFFER AMP B	ON	ON	ON	ON	ON	ON	ON	ON
	REC AMP	OFF	OFF	ON	ON	OFF	OFF	ON	ON
	ALC CIRCUIT	ON	ON	ON	ON	ON	ON	ON	ON
	ALC DISCHARGE	ON	ON	OFF	OFF	ON	ON	OFF	OFF
MONITOR AMP	ON	ON	MUTE	ON	ON	ON	ON	ON	

OPERATION MODE BY EXTERNAL SWITCH (2 / 2)

SW POSITION	MIC MODE	G : EXT MIC O : MIC OFF H : INT MIC	OPEN MIC MODE							
	REC / PLAY	SW ₃ (21) O : PLAY H : REC	OPEN PLAY BACK MODE				V _{CC} RECORDING MODE			
	SOURCE SELECT	SW ₂ (15) O : $\overline{\text{TAPÉ}}$ H : TAPE	V _{CC}		OPEN		V _{CC}		OPEN	
		SW ₁ (17) O : LINE H : RADIO	V _{CC}	OPEN	V _{CC}	OPEN	V _{CC}	OPEN	V _{CC}	OPEN
OPERATION MODE	INPUT / SOURCE	TAPE	LINE	RADIO	MIC	LINE	RADIO			
	MONITOR OUT	○	○	○		○	○			
	REC OUT				○	○	○			
INTERNAL OPERATION	NAB AMP	ON	ON	OFF	OFF					
	BUFFER AMP A	OFF	OFF	ON	ON					
	LINE / RADIO SW	LINE	RADIO	LINE	RADIO	LINE	RADIO	LINE	RADIO	
	TAPE / $\overline{\text{TAPÉ}}$ SW	TAPE	$\overline{\text{TAPÉ}}$	TAPE	$\overline{\text{TAPÉ}}$					
	MIC AMP	MUTE	MUTE	MUTE	MUTE					
	BUFFER AMP B	ON	ON	ON	ON					
	REC AMP	OFF	OFF	ON	ON					
	ALC CIRCUIT	ON	ON	ON	ON					
	ALC DISCHARGE	ON	ON	OFF	OFF					
MONITOR AMP	ON	ON	ON	ON						

LEVEL DIAGRAM

(1) TAPE IN ⇒ MONITOR OUT (52dB at 315Hz)

TAPE IN	⇒	NAB AMP	⇒	BUF. AMP	⇒	MONI. AMP	⇒	MONI. OUT
G_V	:	45dB (315Hz)		0dB		7dB		
LEVEL	:	0.154mV _{rms} (-74dBm)		0.027V _{rms} (-29dBm)		0.027V _{rms} (-29dBm)		0.062V _{rms} (-22dBm)

(2) RADIO IN ⇒ MONITOR OUT (-2dB)

RADIO IN	⇒	ATT.	⇒	BUF. AMP	⇒	MONI. AMP	⇒	MONI. OUT
G_V	:	-9dB		0dB		7dB		
LEVEL	:	0.078V _{rms} (-20dBm)		0.027V _{rms} (-29dBm)		0.027V _{rms} (-29dBm)		0.062V _{rms} (-22dBm)

(3) RADIO IN ⇒ REC OUT (17dB)

RADIO IN	⇒	ATT.	⇒	ALC	⇒	REC AMP	⇒	REC OUT
G_V	:	-9dB				26dB		
LEVEL	:	0.069V _{rms} (-21dBm)		0.025V _{rms} (-30dBm)		0.025V _{rms} (-30dBm)		0.489V _{rms} (-4dBm)

(4) LINE IN ⇒ MONITOR OUT (7dB)

LINE IN	⇒	BUF. AMP	⇒	MONI. AMP	⇒	MONI. OUT
G_V	:	0dB		7dB		
LEVEL	:	0.027V _{rms} (-29dBm)		0.027V _{rms} (-29dBm)		0.062V _{rms} (-22dBm)

(5) LINE IN ⇒ REC OUT (26dB)

LINE IN	⇒	BUF. AMP	⇒	ALC	⇒	REC AMP	⇒	REC OUT
G_V	:	0dB				26dB		
LEVEL	:	0.025V _{rms} (-30dBm)		0.025V _{rms} (-30dBm)		0.025V _{rms} (-30dBm)		0.489V _{rms} (-4dBm)

(6) MIC IN ⇒ MONITOR OUT (26.5dB)

MIC IN	⇒	MIC AMP	⇒	BUF. AMP	⇒	MONI. AMP	⇒	MONI. OUT
G_V	:	19.5dB		0dB		7dB		
LEVEL	:	2.913mV _{rms} (-48.5dBm)		0.027V _{rms} (-29dBm)		0.027V _{rms} (-29dBm)		0.062V _{rms} (-22dBm)

(7) MIC IN ⇒ REC OUT (45.5dB)

MIC IN	⇒	MIC AMP	⇒	BUF. AMP	⇒	ALC	⇒	REC AMP	⇒	REC OUT
G_V	:	19.5dB		0dB				26dB		
LEVEL	:	2.596mV _{rms} (-49.5dBm)		0.025V _{rms} (-30dBm)		0.025V _{rms} (-30dBm)		0.025V _{rms} (-30dBm)		0.489V _{rms} (-4dBm)

MAXIMUM RATING (Ta = 25°C)

CHARACTERISTIC	SYMBOL	RATING	UNIT
Supply Voltage	V _{CC}	9	V
Power Dissipation	P _D (Note)	1200	mW
Operating Temperature	T _{opr}	- 25~75	°C
Storage Temperature	T _{stg}	- 55~155	°C

(Note) : Derated above Ta = 25°C in the proportion of 9.6mW/°C.

ELECTRICAL CHARACTERISTICS

(Unless otherwise specified, V_{CC} = 5V, f = 1kHz, Ta = 25°C, BW = 400Hz~30kHz)

CHARACTERISTIC		SYM-BOL	TEST CIR-CUIT	TEST CONDITION	MIN.	TYP.	MAX.	UNIT	
Quiescent Current		I _{CCQ1}	—	REC MODE	6.0	10.0	16.0	mA	
		I _{CCQ2}	—	PLAY MODE	4.0	7.5	13.0		
Reference Voltage		V _{REF}	—		—	2.1	—	V	
Control Voltage Range	TAPE / TAPE SW (SW ₁ : Pin 15)	V _{TH1A}	—	TAPE MODE (OPEN)	0	—	0.2	V	
		V _{TH1B}	—	TAPE MODE	1.3	—	V _{CC}		
	RADIO / LINE SW (SW ₂ : Pin 17)	V _{TH2A}	—	RADIO MODE (OPEN)	0	—	0.2		
		V _{TH2B}	—	LINE MODE	1.3	—	V _{CC}		
	REC / PLAY SW (SW ₃ : Pin 21)	V _{TH3A}	—	PLAY MODE (OPEN)	0	—	0.2		
		V _{TH3B}	—	REC MODE	1.3	—	V _{CC}		
	MIC SW (SW ₄ : Pin 23)	V _{TH4A}	—	EXT MIC MODE	0	—	0.2		
		V _{TH4B}	—	MIC OFF MODE (OPEN)	—	OPEN	—		
V _{TH4C}		—	INT MIC MODE	1.6	—	V _{ref}			
RADIO Mode	Playback	Voltage Gain	G _{v1}	—	V _{out} = - 10dBV	- 4	- 2	0	dB
		Maximum Output Voltage	V _{om1}	—	THD = 1%	1.0	1.2	—	V _{rms}
		Output Noise Voltage	V _{no1}	—	MIC OFF MODE, R _g = 620Ω, DIN AUDIO	—	- 98	- 90	dBV
		Total Harmonic Distortion	THD1	—	V _{out} = - 10dBV	—	0.2	—	%
		Cross Talk	C.T.1	—	V _{out} = - 10dBV	—	- 60	—	dB
		Ripple Rejection Ratio	R.R.1	—	MIC OFF MODE, V _{rip} = - 20dBV, f = 100Hz, BW = ~30kHz	—	- 52	—	dB

CHARACTERISTIC		SYM-BOL	TEST CIR-CUIT	TEST CONDITION		MIN.	TYP.	MAX.	UNIT	
RADIO Mode	REC	Voltage Gain	G _{v2}	—	V _{out} = -10dBV		15	17	19	dB
		Output Noise Voltage	V _{no2}	—	MIC OFF MODE, R _g = 620Ω, DIN AUDIO		—	-77	-68	dBV
		Total Harmonic Distortion	THD2	—	V _{in} = -6dBV, ALC = ON		—	0.3	—	%
		Cross Talk	C.T.2	—	V _{out} = -10dBV		—	-57	—	dB
		Ripple Rejection Ratio	R.R.2	—	MIC OFF MODE, V _{rip} = -20dBV, f = 100Hz, BW = ~30kHz		—	-40	—	dB
		ALC Level	ALC21	—	V _{in} = -16dBV	Dual channel input	-4	-2	0	dBV
ALC22	—		V _{in} = 4dBV	-4	-1		2			
LINE Mode	Playback	Voltage Gain	G _{v3}	—	V _{out} = -10dBV		5	7	9	dB
		Maximum Output Voltage	V _{om3}	—	THD = 1%		1.0	1.2	—	V _{rms}
		Output Noise Voltage	V _{no3}	—	MIC OFF MODE, R _g = 620Ω, DIN AUDIO		—	-98	-90	dBV
		Total Harmonic Distortion	THD3	—	V _{out} = -10dBV		—	0.2	—	%
		Cross Talk	C.T.3	—	V _{out} = -10dBV		—	-60	—	dB
		Ripple Rejection Ratio	R.R.3	—	MIC OFF MODE, V _{rip} = -20dBV, f = 100Hz, BW = ~30kHz		—	-52	—	dB
	REC	Voltage Gain	G _{v4}	—	V _{out} = -10dBV		24	26	28	dB
		Output Noise Voltage	V _{no4}	—	MIC OFF MODE, R _g = 620Ω, DIN AUDIO		—	-77	-68	dBV
		Total Harmonic Distortion	THD4	—	V _{in} = -16dBV, ALC = ON		—	0.3	—	%
		Cross Talk	C.T.4	—	V _{out} = -10dBV		—	-56	—	dB
		Ripple Rejection Ratio	R.R.4	—	MIC OFF MODE, V _{rip} = -20dBV, f = 100Hz, BW = ~30kHz		—	-37	—	dB
		ALC Level	ALC41	—	V _{in} = -26dBV	Dual channel input	-4	-2	0	dBV
ALC42	—		V _{in} = -6dBV	-4	-1		2			

CHARACTERISTIC		SYM-BOL	TEST CIR-CUIT	TEST CONDITION	MIN.	TYP.	MAX.	UNIT	
TAPE Mode	Open Loop Voltage Gain	G _{vo5}	—	V _{out} = -10dBV	—	97	—	dB	
	Closed Loop Voltage Gain	G _{v5}	—	V _{out} = -10dBV	41.5	43.5	45.5	dB	
	Maximum Output Voltage	V _{om5}	—	THD = 1%	1.0	1.2	—	V _{rms}	
	Output Noise Voltage	V _{no5}	—	MIC OFF MODE, R _g = 620Ω, DIN AUDIO	—	-73	-65	dBV	
	Total Harmonic Distortion	THD5	—	V _{out} = -10dBV	—	0.2	—	%	
	Cross Talk	C.T.5	—	V _{out} = -10dBV	—	-57	—	dB	
	Ripple Rejection Ratio	R.R.5	—	MIC OFF MODE, V _{rip} = -20dBV, f = 100Hz, BW = ~30kHz	—	-33	—	dB	
MIC Mode	Playback	Voltage Gain	G _{v6}	—	V _{out} = -10dBV	25.5	27.5	29.5	dB
		Maximum Output Voltage	V _{om6}	—	THD = 1%	1.0	1.2	—	V _{rms}
		Output Noise Voltage	V _{no6}	—	EXT. MIC MODE, R _g = 620Ω, DIN AUDIO	—	-87	-79	dBV
		Total Harmonic Distortion	THD6	—	V _{out} = -10dBV	—	0.24	—	%
		Ripple Rejection Ratio	R.R.6	—	INT. MIC MODE, V _{rip} = -20dBV, f = 100Hz, BW = ~30kHz	—	-52	—	dB
	REC	Voltage Gain	G _{v7}	—	V _{out} = -10dBV	44.5	46.5	48.5	dB
		Maximum Output Voltage	V _{om7}	—	THD = 1%, ALC = OFF	1.0	1.2	—	V _{rms}
		Output Noise Voltage	V _{no7}	—	INT. MIC / EXT. MIC MODE, R _g = 620Ω, DIN AUDIO	—	-70	-61	dBV
		Total Harmonic Distortion	THD7	—	V _{in} = -36dBV, ALC = ON	—	0.3	—	%
		Ripple Rejection Ratio	R.R.7	—	INT. MIC / EXT. MIC MODE, V _{rip} = -20dBV, f = 100Hz, BW = ~30kHz	—	-47	—	dB
		ALC Level	ALC71	—	V _{in} = -46dBV	Dual channel input	-4	-2	0
	ALC72	—	V _{in} = -26dBV	-4	-1		2		

DC VOLTAGE AT EACH TERMINAL ($V_{CC} = 5V$, $V_{in} = 0$, $T_a = 25^\circ C$)

TERMINAL No.	1	2	3	4	5	6	7	8
DC VOLTAGE [V]	1.0 (REC)	2.1	2.1	2.1	2.1	2.1	0 (GND)	2.1
	0.1 (PLAY)							
TERMINAL No.	9	10	11	12	13	14	15	16
DC VOLTAGE [V]	2.1	2.1	2.1	2.1	2.1	2.1	0 (OPEN)	2.1
TERMINAL No.	17	18	19	20	21	22	23	24
DC VOLTAGE [V]	0 (OPEN)	2.1	5.0 (V_{CC})	2.1	0 (OPEN)	2.1	0 (OPEN)	2.1

TEST CIRCUIT

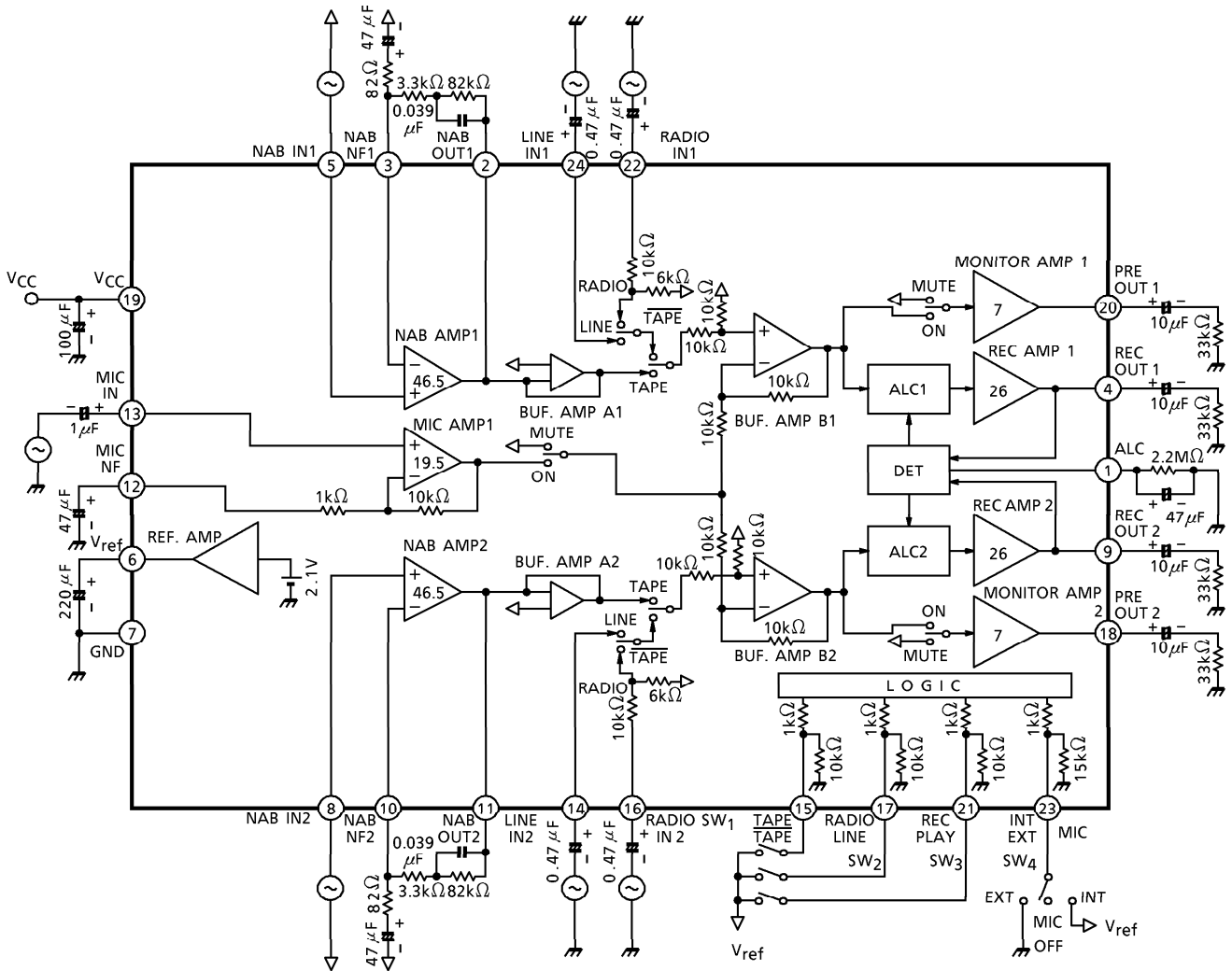

(*) 23pin : For mic off mode, should be open. Don't add any external voltage.

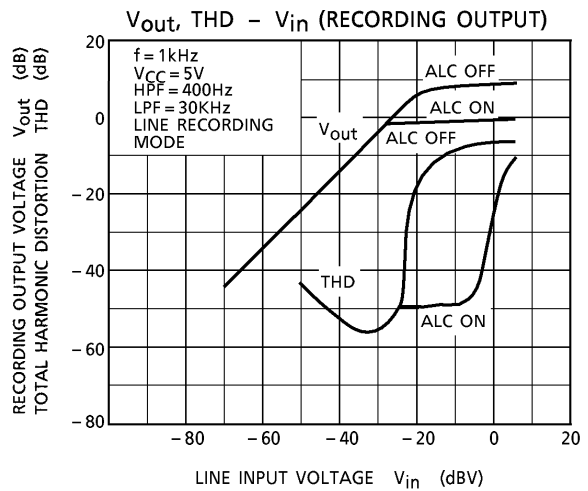
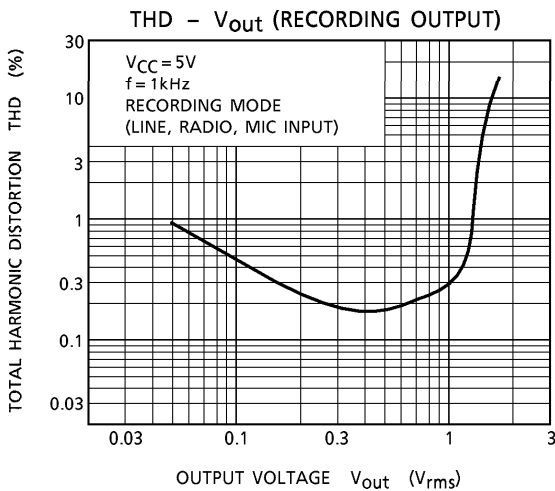
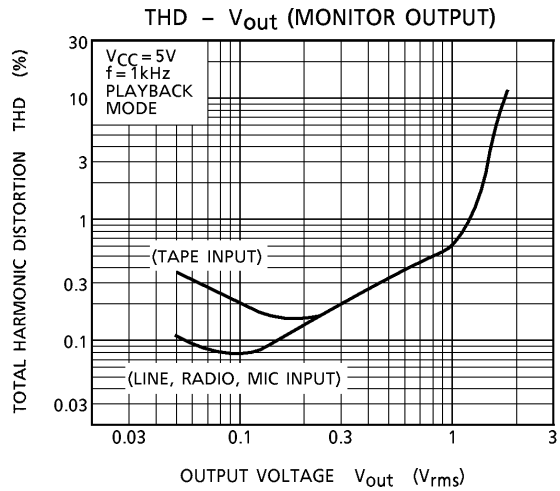
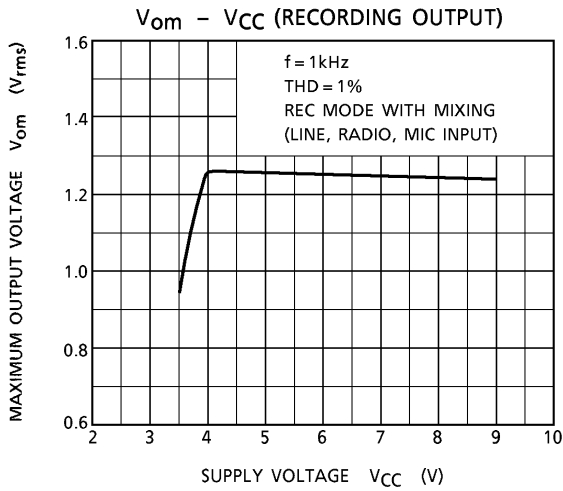
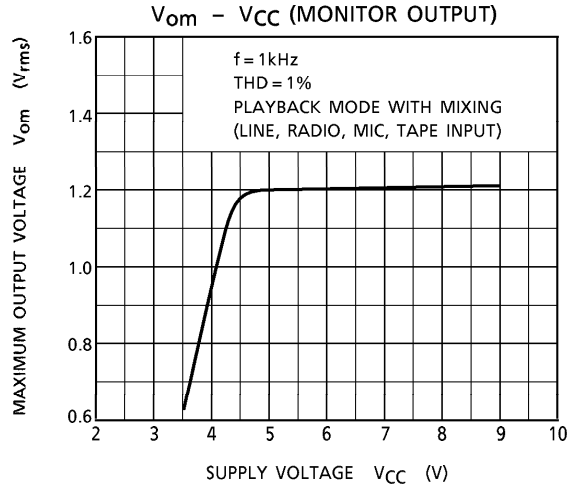
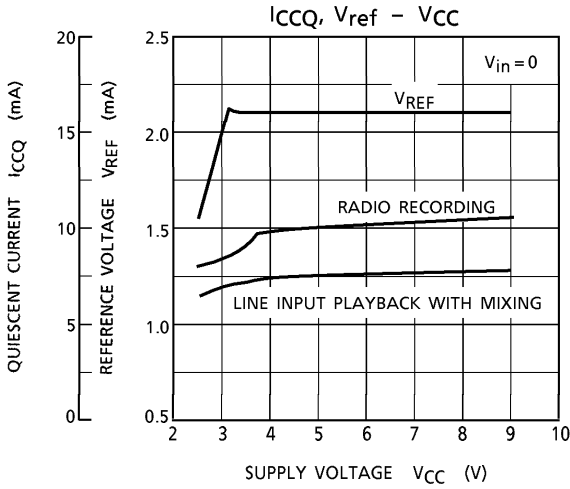

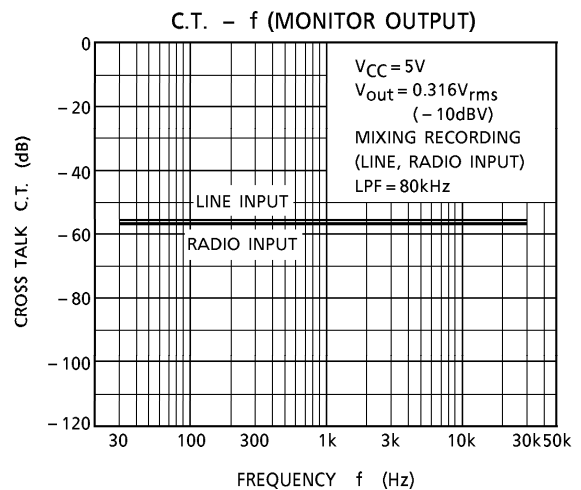
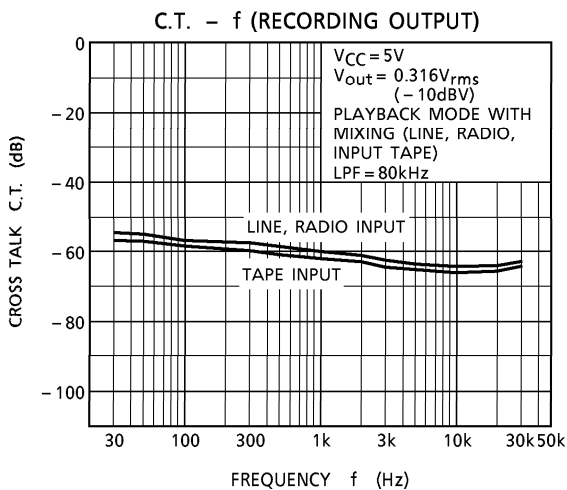
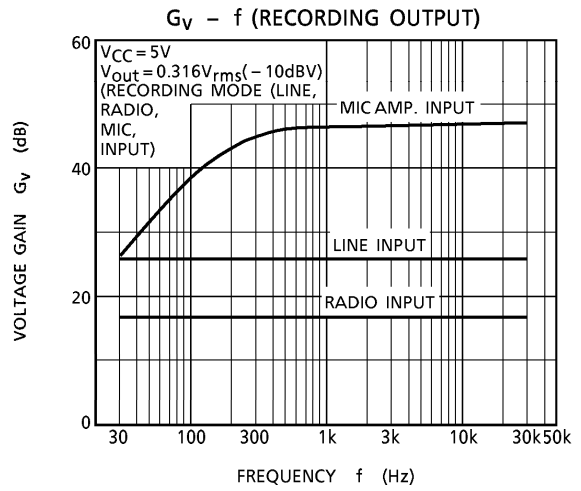
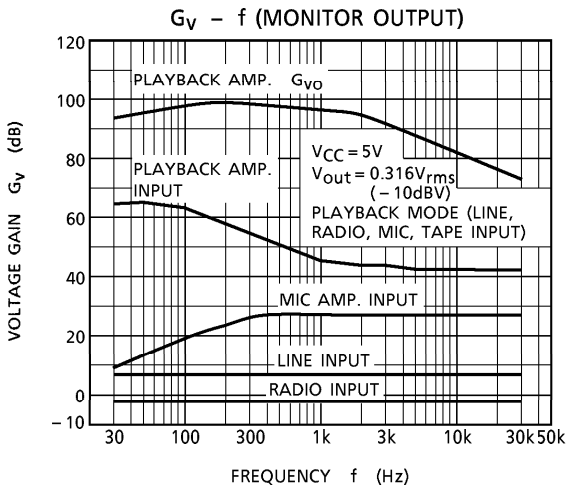
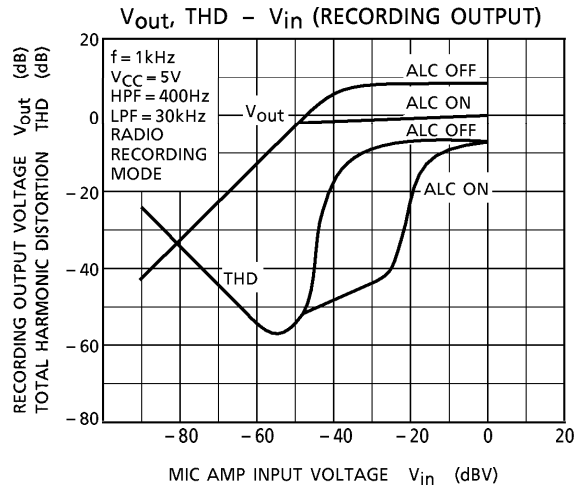
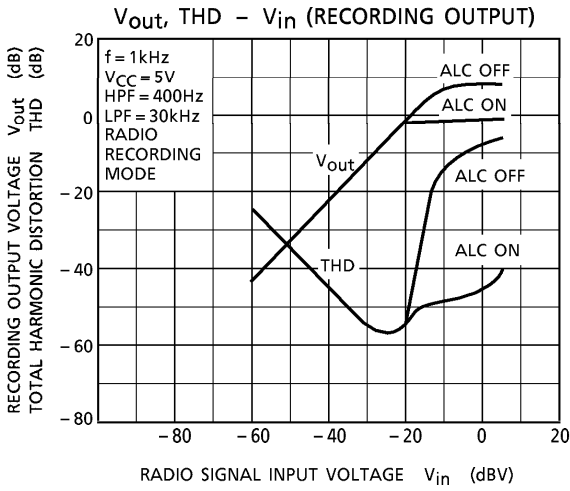

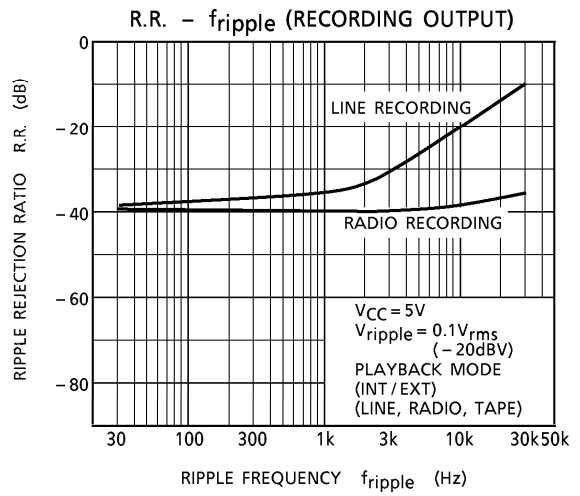
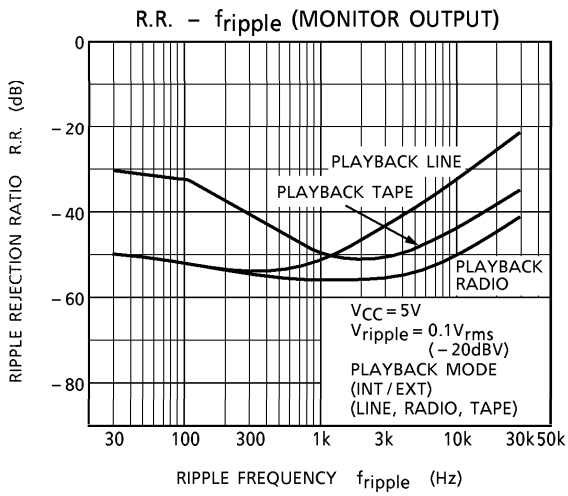

PACKAGE DIMENSIONS
SDIP24-P-300-1.78

Unit : mm

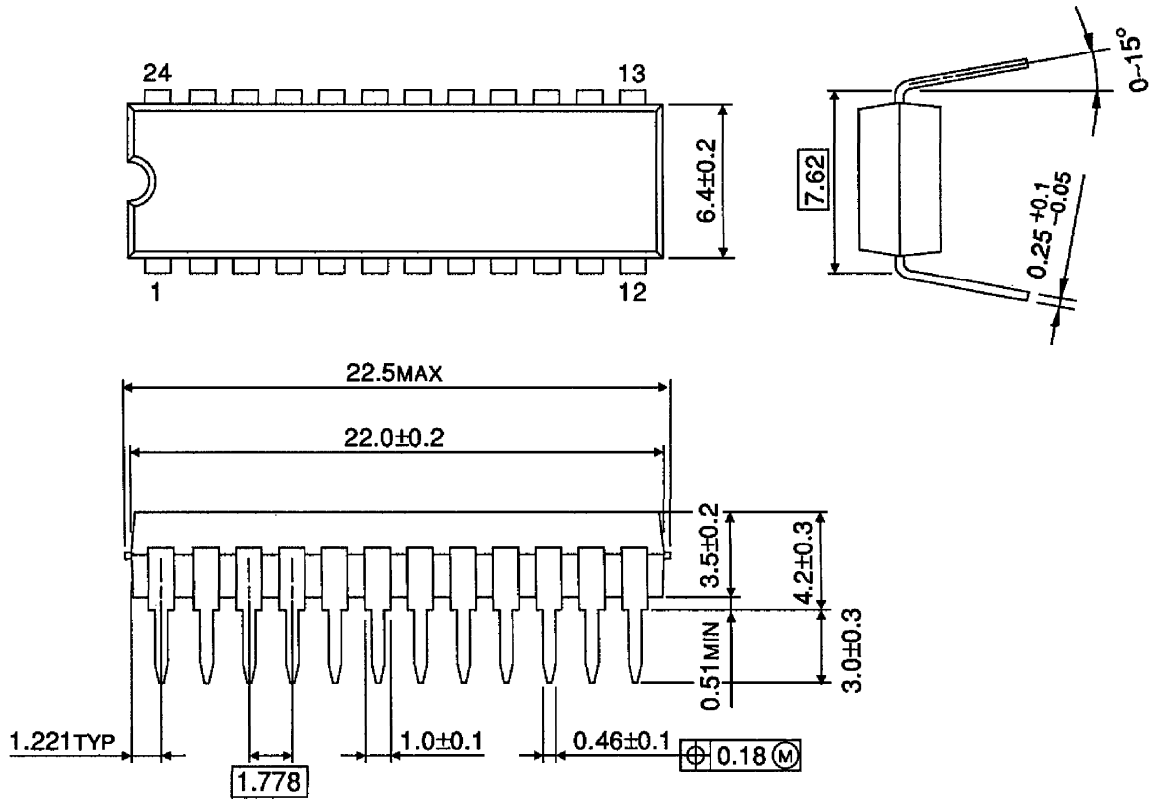

Weight : 1.2g (Typ.)

RESTRICTIONS ON PRODUCT USE

000707EBA

- TOSHIBA is continually working to improve the quality and reliability of its products. Nevertheless, semiconductor devices in general can malfunction or fail due to their inherent electrical sensitivity and vulnerability to physical stress. It is the responsibility of the buyer, when utilizing TOSHIBA products, to comply with the standards of safety in making a safe design for the entire system, and to avoid situations in which a malfunction or failure of such TOSHIBA products could cause loss of human life, bodily injury or damage to property. In developing your designs, please ensure that TOSHIBA products are used within specified operating ranges as set forth in the most recent TOSHIBA products specifications. Also, please keep in mind the precautions and conditions set forth in the "Handling Guide for Semiconductor Devices," or "TOSHIBA Semiconductor Reliability Handbook" etc..
- The TOSHIBA products listed in this document are intended for usage in general electronics applications (computer, personal equipment, office equipment, measuring equipment, industrial robotics, domestic appliances, etc.). These TOSHIBA products are neither intended nor warranted for usage in equipment that requires extraordinarily high quality and/or reliability or a malfunction or failure of which may cause loss of human life or bodily injury ("Unintended Usage"). Unintended Usage include atomic energy control instruments, airplane or spaceship instruments, transportation instruments, traffic signal instruments, combustion control instruments, medical instruments, all types of safety devices, etc.. Unintended Usage of TOSHIBA products listed in this document shall be made at the customer's own risk.
- The products described in this document are subject to the foreign exchange and foreign trade laws.
- The information contained herein is presented only as a guide for the applications of our products. No responsibility is assumed by TOSHIBA CORPORATION for any infringements of intellectual property or other rights of the third parties which may result from its use. No license is granted by implication or otherwise under any intellectual property or other rights of TOSHIBA CORPORATION or others.
- The information contained herein is subject to change without notice.