

## HITACHI VIDEO MONITOR



# VM-902

*A 9 inch monochrome video monitor for CCTV and general purpose video applications.*

### FEATURES

- Excellent resolution due to wide-band video amplifier.
- Accurate deflection linearity due to special deflection distortion correction design.
- Video bridging allows a single video signal to be looped between monitors.
- Wide use of integrated circuits assure reliability and stability.

# HITACHI VIDEO MONITOR

## VM-902

### KEY SPECIFICATIONS

Video input:	Composite video signal, 1.0 Vp-p, sync negative	Ambient temperature:	-10 to 50°C (14 or 122°F)
Input impedance:	75 Ω or high	Power supply:	U: 120V AC, 60Hz E,K: 220/240V AC, 50Hz
Resolution:	Horizontal: Over 600 lines Vertical: Over 300 lines	Power consumption:	27W approx.
Deflection linearity:	2% or better at center (with respect to picture height)	Dimensions:	220(W) × 230(H) × 246(D)mm (8.7 × 9.1 × 9.7 in) (excluding projections)
High voltage:	10.5kV approx.	Weight:	5.9kg approx. (13 lb)
Picture tube:	9-inch, 90° deflection, 240XB4A or equivalent		

### DIMENSIONS

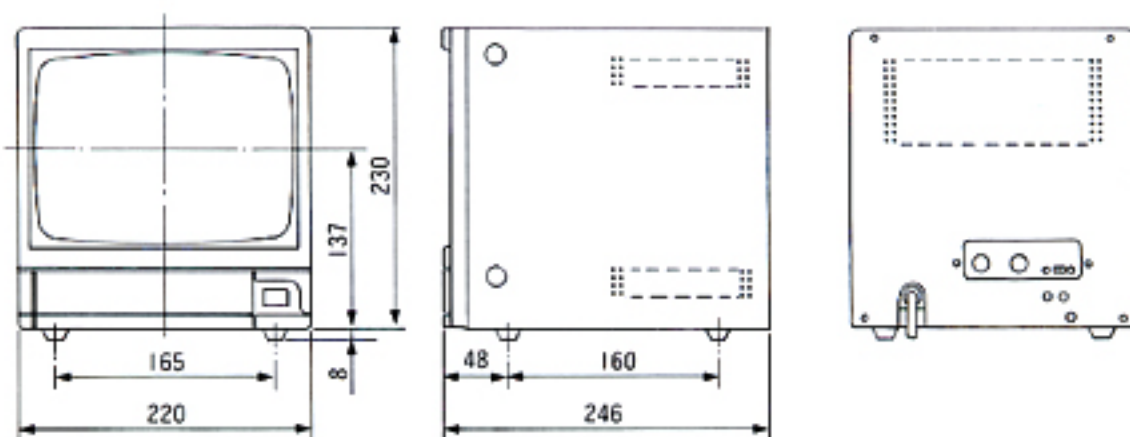

(Unit : mm)

- Note** • The products and their specifications herein described are subject to change without notice. When placing an order of the products, please make sure whether the information of this material is the latest.  
• Hitachi Denshi, Ltd. warrants that these products meet the standard warranty conditions of Hitachi Denshi, Ltd.

Hitachi Denshi, Ltd. carries out inspection and other quality control of the products within the range required to provide this warranty.

- It is recommended that to maintain your video product or system in good working order you are advised to discuss with the vendor an appropriate maintenance package to meet your requirements.

*Specifications are subject to change without notice.*

## Hitachi Denshi, Ltd

Head Office : 1-8-68 Hibiya 3-chome, Chiyoda-ku, Tokyo 100-8004, Japan  
Phone (03)421-5211, Fax (03)421-5296

### Hitachi Denshi America, Ltd.

Head Office : 132 Crossways Park Drive, Woodbury, New York 11797, U.S.A.  
Phone (516)821-7200, Fax (516)821-5793

Chicago Office : 420 East Devon Ave., Suite 110, Rosemead, IL 60143-1201, U.S.A.  
Phone (815)250-8050, Fax (815)250-8054

Los Angeles Office : 371 Van Nuys Way, Suite 120, Torrance, California 90501, U.S.A.  
Phone (714)259-8116, Fax (714)259-8050

Dallas Office : 2100 West N.W. Highway, Suite 1140, Grapevine, TX 76051, U.S.A.  
Phone (817)489-4525, Fax (817)489-4734

Atlanta Office : 2029 Arrowood Road, Suite 110, Atlanta, Georgia 30360, U.S.A.  
Phone (770)242-3636, Fax (770)242-6839

### Hitachi Denshi, Ltd. (Canada)

Head Office : 1 Selkirk Avenue Unit 4-14, Scarborough, Ontario CANADA M1V 5J3  
Phone (416)299-6280, Fax (416)299-0462

London Office : 1770 Chelms St., Vaughan, Ontario CANADA M5G 1S6  
Phone (514)332-6687, Fax (514)332-1964

Ottawa Office : 9 Belfrage Drive, Nepean, Ontario CANADA K2E 7V5  
Phone (613)721-7931, Fax (613)625-4251

### Hitachi Denshi (Europe), GmbH

Head Office : Weiskircher Str. 7a 85, Jochenheim D-62110 Rodgau, Germany  
Phone (0619)4390-1, Fax (0619)4390

### Hitachi Denshi (U.K.), Ltd.

Head Office : 18 Spink's Industrial Estate, Irving Way, Hemel, Herts, SG9 6AG, United Kingdom  
Phone (0494)652-4711, Fax (01494)252-1467

Leeds Office : Brookfield House, Selby Road, Garforth Leeds, LS25 1AB, United Kingdom  
Phone (0113)2674600, Fax (0113)2674300

### Hitachi Denshi - Ltd.

Singapore Branch : 10 Raffles Road #20-15 International Plaza Singapore 37960  
Phone (65)223-8800, Fax (65)223-0206

Beijing Office : Beijing Fortune Building 3, Dong Sanhuan Beilu, Chaoyang District, Beijing, China  
Phone (861)4222-4222, Fax (861)4222-4222

