

TOSHIBA BIPOLAR LINEAR INTEGRATED CIRCUIT SILICON MONOLITHIC

# TA8194Z

## MUTING IC

The TA8194Z is a muting IC to prevent the "POP" noise made at time of power ON and OFF of audio equipments. This IC has 4 sensor terminals, muting control terminal and supply control terminal. In case of sensing voltage rising, muting control signal occurs and after that supply control signal occurs and muting signal maintains for 1s. In case of sensing voltage setting, muting control signal occurs and after that supply control signal stops. This IC also has manual muting terminal and protection function.

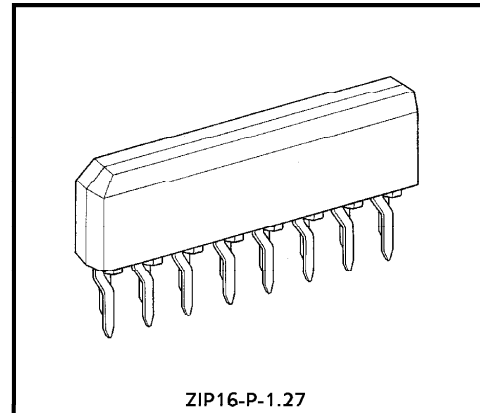

ZIP16-P-1.27

Weight : 0.99g (Typ.)

### FEATURES

- 4 sensor terminals :  $V_{CC}$ , B<sub>1</sub>, B<sub>2</sub>, B<sub>3</sub>
- Muting circuit control signal output
- Power supply circuit control signal output
- Manual muting control terminal
- Protection function terminal
- Operating supply voltage range :  $V_{CC}(\text{opr.}) = 8 \sim 18.0\text{V}$  ( $T_a = 25^\circ\text{C}$ )

961001EBA1

- TOSHIBA is continually working to improve the quality and the reliability of its products. Nevertheless, semiconductor devices in general can malfunction or fail due to their inherent electrical sensitivity and vulnerability to physical stress. It is the responsibility of the buyer, when utilizing TOSHIBA products, to observe standards of safety, and to avoid situations in which a malfunction or failure of a TOSHIBA product could cause loss of human life, bodily injury or damage to property. In developing your designs, please ensure that TOSHIBA products are used within specified operating ranges as set forth in the most recent products specifications. Also, please keep in mind the precautions and conditions set forth in the TOSHIBA Semiconductor Reliability Handbook.
- The products described in this document are subject to foreign exchange and foreign trade control laws.
- The information contained herein is presented only as a guide for the applications of our products. No responsibility is assumed by TOSHIBA CORPORATION for any infringements of intellectual property or other rights of the third parties which may result from its use. No license is granted by implication or otherwise under any intellectual property or other rights of TOSHIBA CORPORATION or others.
- The information contained herein is subject to change without notice.

BLOCK DIAGRAM

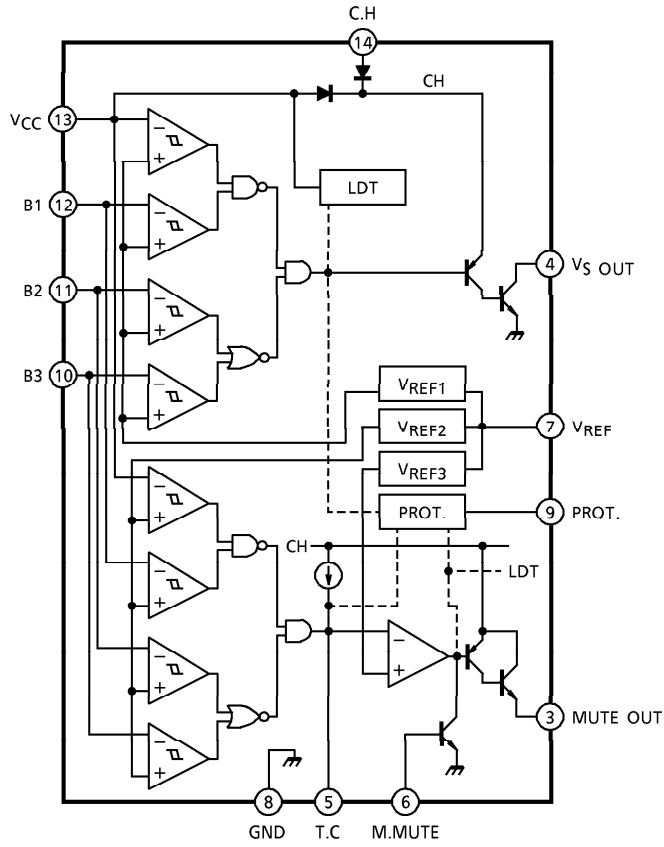

TERMINAL EXPLANATION

PIN No.	FUNCTION	EQUIVALENT CIRCUIT
3	MUTE OUT	
	Muting Control Signal Output	
4	V <sub>S</sub> OUT	
	Supply Control Signal Output	
5	TC (Timing Condenser)	
	Muting Time Condenser Terminal	
6	M. MUTE (Manual Mute)	
	$V_6 \geq 0.8V \rightarrow \text{MUTE OUT} = \text{ON}$	
7	V <sub>REF</sub> (Reference Voltage)	
	Reference Voltage for Comparator	

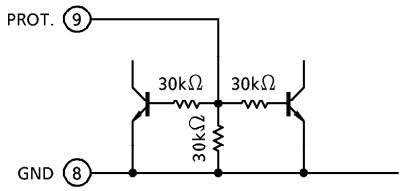
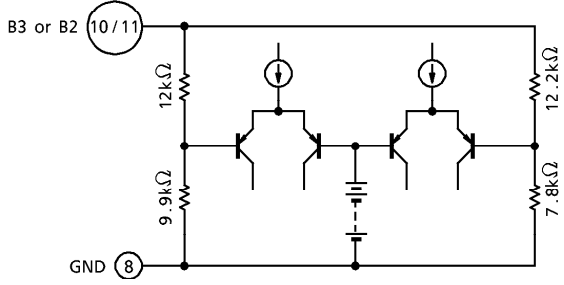
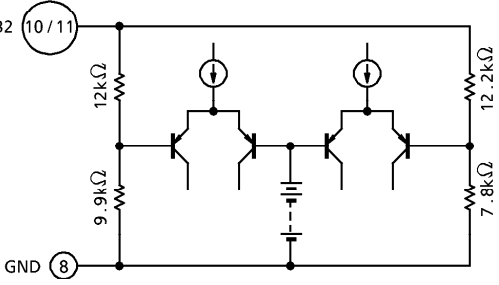
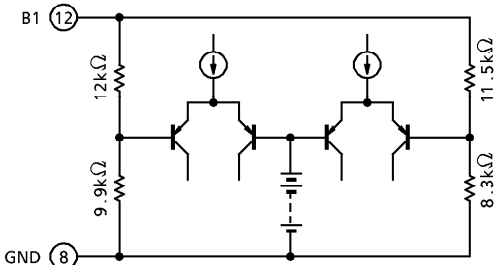
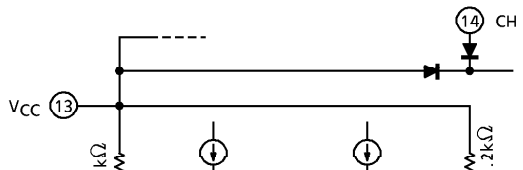
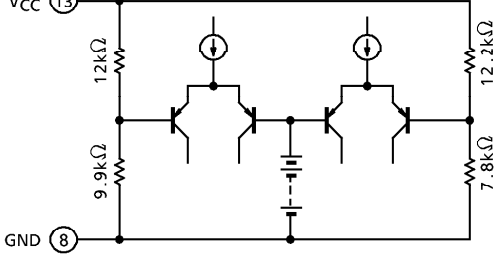
PIN No.	FUNCTION	EQUIVALENT CIRCUIT
9	PROT. (Protection)  $V_9 \geq 0.8V \rightarrow \text{MUTE OUT} = \text{ON},$ $V_S \text{ OUT} = \text{OFF}$	
10	B3 Voltage Sense Terminal-3	
11	B2 Voltage Sense Terminal-2	
12	B1 Voltage Sense Terminal-1	
13	$V_{CC}$  Supply Terminal Voltage Sense Terminal	
14	CH (Charge Hold)  Back Up Capacitor Terminal at $V_{CC}$ OFF	

## OPERATING DESCRIPTION

The TA8194Z is a muting control IC to prevent pop noise made at time of power ON and OFF of audio equipments.

This IC has built-in 4 terminals for sensing bias line voltage of audio equipment.

According to sensing voltage rising and setting, this IC occurs muting control signal and supply control signal.

Followings are basic operation of this IC, refer to TIMING CHART : page 6.

- (1) Muting control signal occurs at  $V_{CC}$  ON under any condition of B1, B2, B3 sensing voltage.
- (2) Muting control signal occurs at  $V_S$  output OFF.
- (3) Muting control signal stops after ( $T_{M ON}$ ) s at  $V_S$  output ON.  
Muting time ( $T_{M ON}$ ) depends on capacitor value connected to TC terminal : pin⑤.  
( $T_{M ON}$ ) is 1.0~1.1s (Typ.) under condition of  $C_{TC} = 10\mu F$ .  
The above are applied in case sensing voltage rises fast enough.  
Muting control OFF sense voltage : ( $V_{M OFF}$ ) is higher than  $V_S ON$  sense voltage ( $V_{VS ON}$ ), so in case sensing voltage rises slowly, the period sensing voltage rising from ( $V_{VS ON}$ ) to ( $V_{M ON}$ ) should be counted.
- (4) Muting control signal occurs at  $V_{CC}$  OFF. In this case, muting time depends on capacitor value connected to CH terminal : Pin⑭. This capacitor is back-up capacitor at  $V_{CC}$  OFF. Muting control signal operation at  $V_{CC}$  OFF is by charge of this capacitor.
- (5) Manual muting control terminal : pin⑥.  
Muting control signal occurs by adding H-level signal at manual mute control terminal under any condition of  $V_S$  control output.
- (6)  $V_S$  control output signal occurs at condition of sensing terminal voltage is following.  
$$V_{CC} \cdot B1 \cdot (B2 + B3) = \text{H-level}$$
- (7) Sense voltage of  $V_S ON/OFF$  and muting ON/OFF control are set individually, so control signal output operate sequentially as follows.
  - Sensing voltage rising :  $V_S$  control output signal stop after muting control signal occurs.  
( $V_{M ON} > V_{VS OFF}$ )
  - Sensing voltage setting : Muting control signal stops after ( $T_{M ON}$ ) s at sensing voltage setting to ( $V_{M OFF}$ ) after  $V_S$  control output occurs. ( $V_{VS ON} < V_{M OFF}$ )

There are muting period before and after at  $V_S$  control signal stops and occurs.
- (8) Sense voltage of  $V_S ON/OFF$  and muting ON/OFF control have hysteresis voltage of 0.2~0.3V.
- (9) Protection function terminal : pin⑨.
  - Adding H-level control signal :  $V_S$  control signal stops and Muting control signal occurs.
  - Adding L-level control signal from H-level :  $V_S$  control signal occurs and after the period :  $DTp OFF$ , muting control signal stops.

$DTp OFF$  depends on capacitor value connected to TC terminal as  $T_{M ON}$ .

TIMING CHART

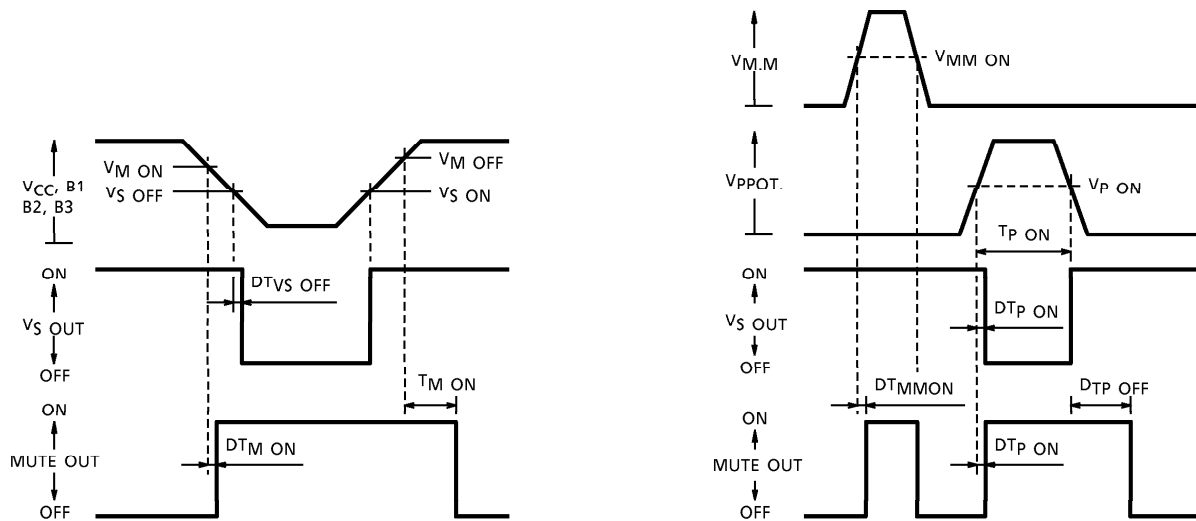
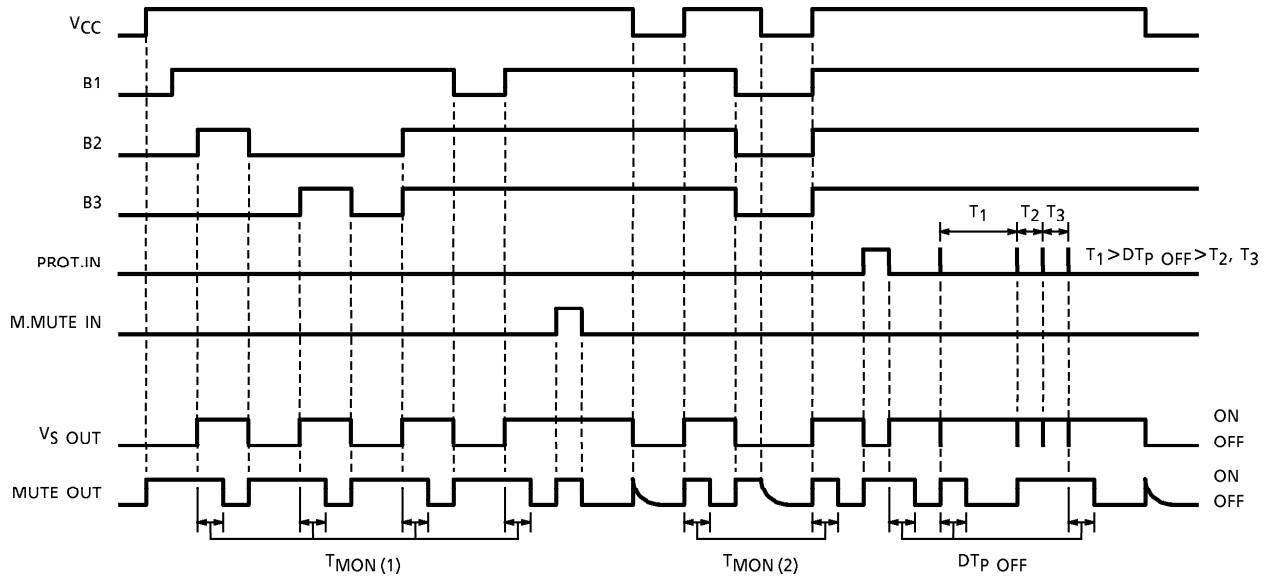

MAXIMUM RATINGS (Ta = 25°C)

CHARACTERISTIC	SYMBOL	RATING	UNIT
Supply Voltage	VCC	25	V
Power Dissipation	PD	750	mW
Operating Temperature	Topr	- 30~85	°C
Storage Temperature	Tstg	- 55~150	°C

ELECTRICAL CHARACTERISTICS (Unless otherwise specified,  $V_{CC} = 14.4V$ ,  $V_{REF} = 6.8V$ ,  $T_a = 25^\circ C$ )

CHARACTERISTIC	SYMBOL	TEST CIRCUIT	TEST CONDITION	MIN.	TYP.	MAX.	UNIT
Quiescent Current	$I_{CCQ}$	—	—	—	19	40	mA
Reference Current	$I_{REF}$	—	—	7.3	9.5	13.5	mA
Mute On Sense Voltage	$V_{M ON (1)}$	—	$V_{CC}$ , B2, B3	8.5	8.7	8.9	V
	$V_{M ON (2)}$	—	B1	7.75	8.0	8.25	
Mute Off Sense Voltage	$V_{M OFF (1)}$	—	$V_{CC}$ , B2, B3	—	9.0	9.2	V
	$V_{M OFF (2)}$	—	B1	—	8.2	9.2	
Mute Out Saturation Voltage	$V_{OUT ML}$	—	$I_{M OUT} = 10mA$	—	1.9	2.5	V
Mute On Dearly Time	$DT_{M ON}$	—	—	—	—	10	$\mu s$
$V_S$ On Mute Time	$T_{M ON (1)}$	—	B1 or B2 or B3 $\rightarrow$ ON	0.7	1.0	1.4	s
	$T_{M ON (2)}$	—	$V_{CC} \rightarrow$ ON	0.8	1.1	1.5	
$V_S$ On Sense Voltage	$V_{VS ON (1)}$	—	$V_{CC}$	—	7.4	8.1	V
	$V_{VS ON (2)}$	—	B1, B2, B3	—	7.3	8.1	
$V_S$ Off Sense Voltage	$V_{VS OFF}$	—	$V_{CC}$ , B1, B2 B3	7.3	7.6	8.0	V
$V_S$ Out Voltage	$V_{OUT VS}$	—	$I_{VS} = -20mA$	—	0.25	1.0	V
$V_S$ Off Dearly Time	$DT_{VS OFF}$	—	—	—	—	10	$\mu s$
Protector On Trigger Voltage	$V_P ON$	—	—	0.8	—	—	V
Protector On Trigger Time	$T_P ON$	—	$V_P = 14.4V$	10	—	—	$\mu s$
Protector On Dearly Time	$DT_P ON$	—	$V_P = 14.4V$	—	—	10	$\mu s$
Protector On Input Current	$I_P IN$	—	$V_P IN = 1V$	—	—	0.1	mA
Protector Off Delay Time	$DT_P OFF$	—	—	0.7	—	1.5	s
Manual Mute On Sense Voltage	$V_{MM ON}$	—	—	0.8	—	—	V
Manual Mute On Dearly Time	$DT_{MM ON}$	—	$V_{MM} = 13.4V$	—	—	10	$\mu s$
Manual Mute On Input Current	$I_{MM IN}$	—	$V_{MM IN} = 1V$	—	—	0.1	mA

TEST CIRCUIT

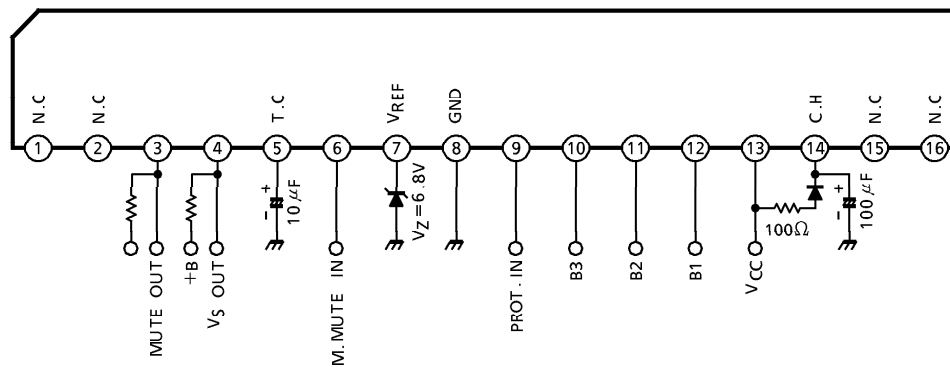

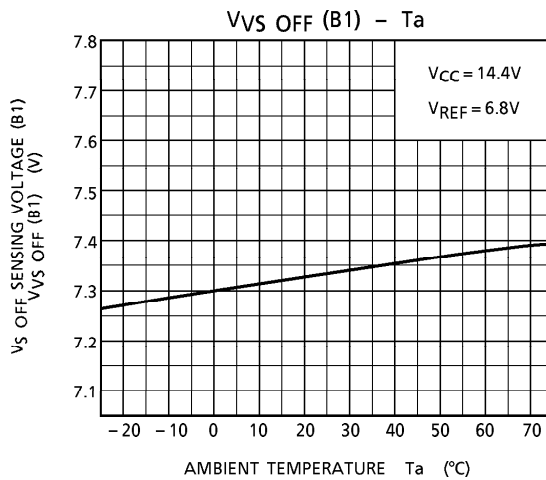
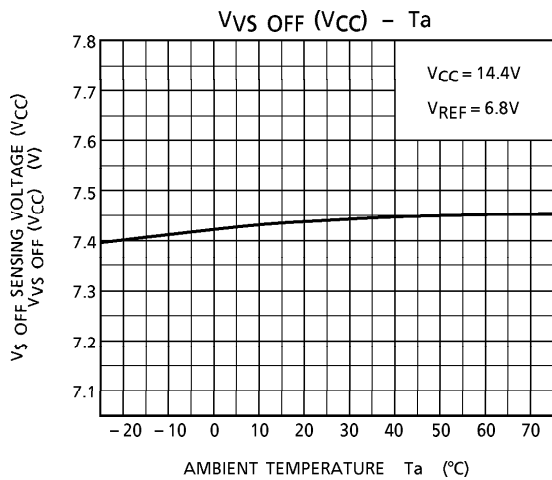
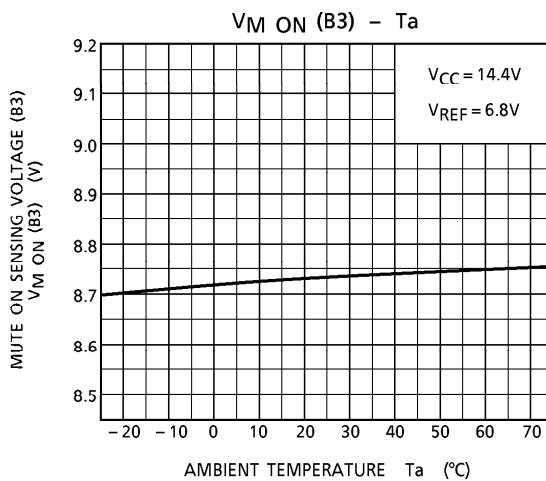
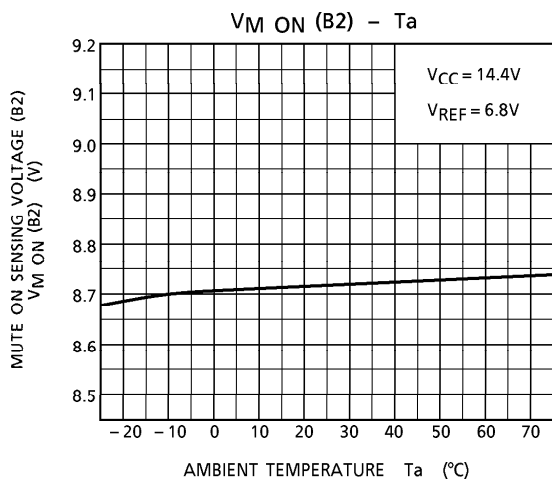
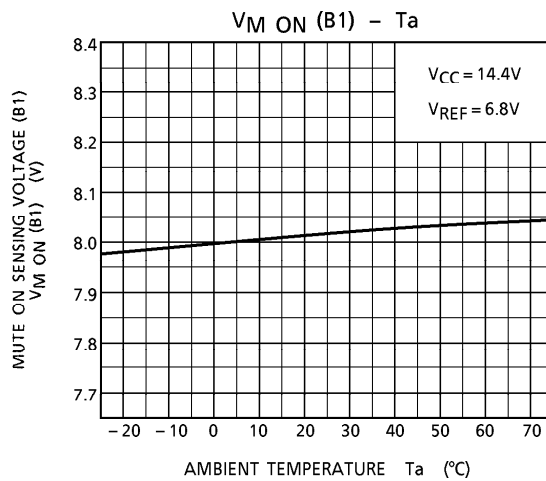
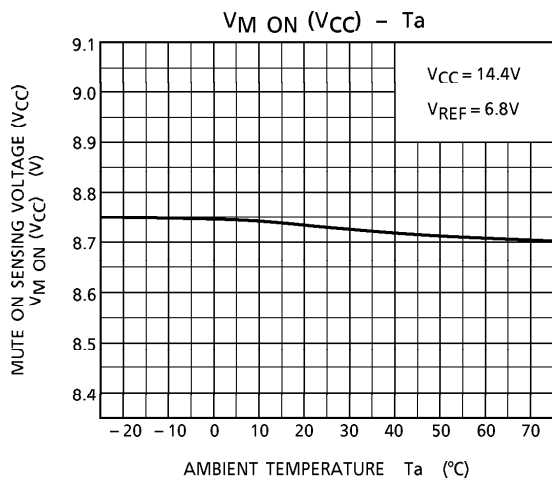



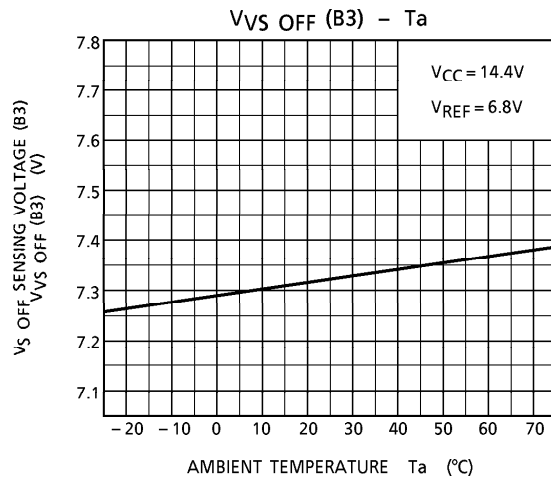
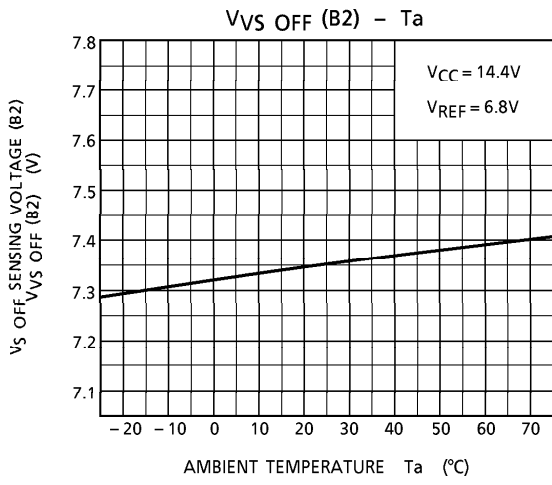

OUTLINE DRAWING  
ZIP16-P-1.27

Unit : mm

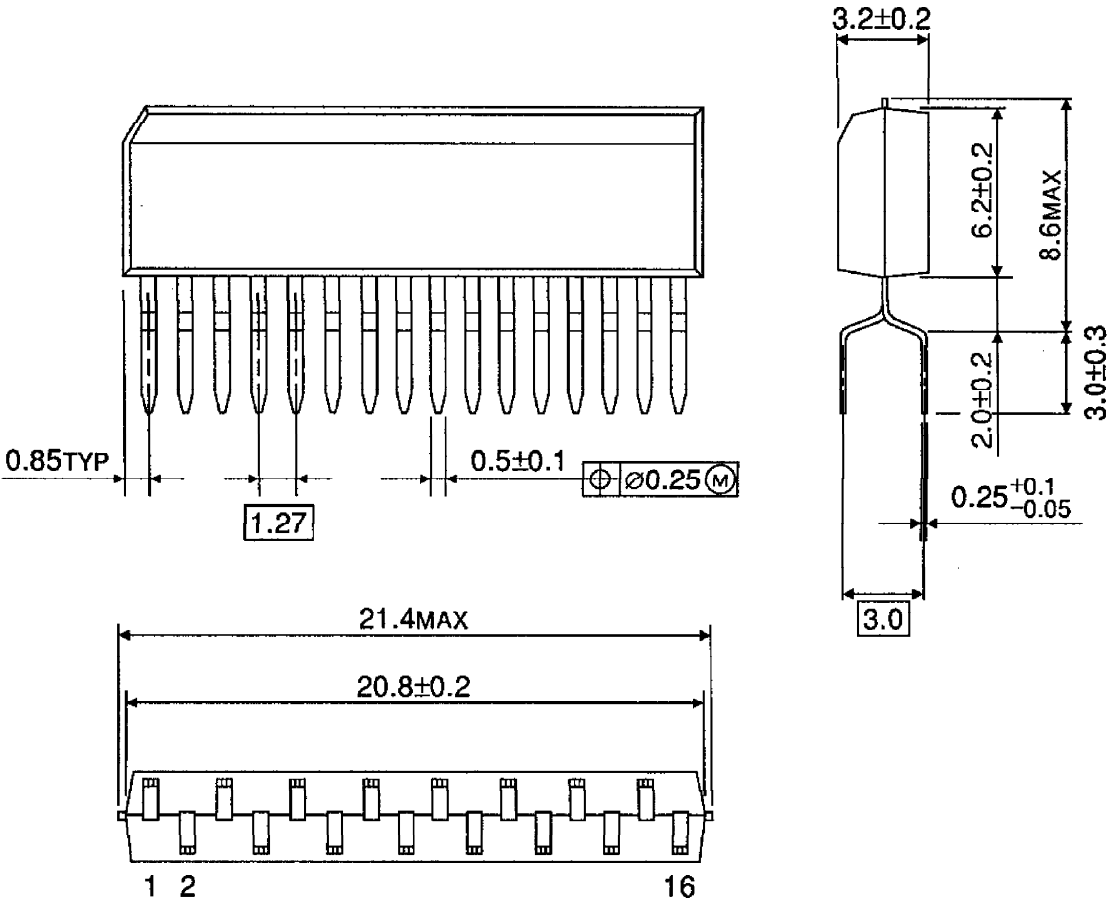

Weight : 0.99g (Typ.)