

FAST SOFT-RECOVERY RECTIFIER DIODES

• With controlled avalanche

Also available to BS9333-F002

Diffused silicon diodes in DO-4 metal envelopes, capable of absorbing transients. They are primarily intended for use in high-frequency power supplies, thyristor inverters and multi-phase power rectifier applications.

The series consists of the following types:

Normal polarity (cathode to stud): BYX30-200 to BYX30-600

Reverse polarity (anode to stud): BYX30-200R to BYX30-600R.

QUICK REFERENCE DATA

	BYX30-200(R)	300(R)	400(R)	500(R)	600(R)
Crest working reverse voltage V_{RWM}	max. 200	300	400	500	600 V
Reverse avalanche breakdown voltage $V_{(BR)R}$	> 250	375	500	625	750 V
Average forward current $I_{F(AV)}$		max.	14		A
Non-repetitive peak forward current I_{FSM}		max.	250		A
Non-repetitive peak reverse power P_{RSM}		max.	18		kW
Reverse recovery time t_{rr}		<	200		ns

MECHANICAL DATA

Dimensions in mm

DO-4; Supplied with device: 1 nut, 1 lock-washer
Nut dimensions across the flats: 9.5 mm

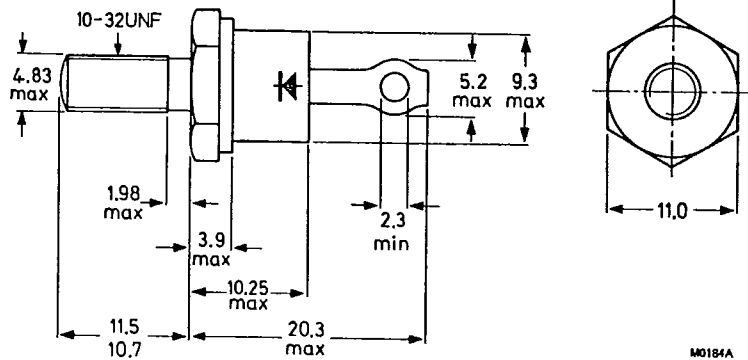

Net mass: 7g

Diameter of clearance hole: max. 5.2 mm

Accessories supplied on request:
see ACCESSORIES section

Torque on nut: min. 0.9 Nm
(9 kg cm)
max. 1.7 Nm
(17 kg cm)

The mark shown applies to the normal polarity types.

RATINGS Limiting values in accordance with the Absolute Maximum System (IEC134)

Voltages ¹⁾		BYX30-200(R)	300(R)	400(R)	500(R)	600(R)
Crest working reverse voltage	V_{RWM}	max. 200	300	400	500	600 V
Continuous reverse voltage	V_R	max. 200	300	400	500	600 V

Currents

Average forward current (averaged over any 20 ms period) up to $T_{mb} = 100\text{ }^\circ\text{C}$ at $T_{mb} = 125\text{ }^\circ\text{C}$	$I_F(AV)$	max. 14 A
	$I_F(AV)$	max. 7.5 A
R.M.S. forward current	$I_F(RMS)$	max. 22 A
Repetitive peak forward current	I_{FRM}	max. 310 A
Non-repetitive peak forward current (t = 10 ms; half-sinewave) $T_j = 150\text{ }^\circ\text{C}$ prior to surge; with reapplied V_{RWM} max.	I_{FSM}	max. 250 A
I^2t for fusing (t = 10 ms)	I^2t	max. 312 A ² s

Reverse power dissipation

Repetitive peak reverse power dissipation t = 10 μ s (square wave; f = 50 Hz) $T_j = 150\text{ }^\circ\text{C}$	P_{RRM}	max. 5.5 kW
Non-repetitive peak reverse power dissipation t = 10 μ s (square wave) $T_j = 25\text{ }^\circ\text{C}$ prior to surge	P_{RSM}	max. 18 kW
$T_j = 150\text{ }^\circ\text{C}$ prior to surge	P_{RSM}	max. 5.5 kW

Temperatures

Storage temperature	T_{stg}	-55 to +150 $^\circ\text{C}$
Junction temperature	T_j	max. 150 $^\circ\text{C}$

THERMAL RESISTANCE

From junction to ambient in free air	$R_{th\ j-a}$	= 50 $^\circ\text{C/W}$
From junction to mounting base	$R_{th\ j-mb}$	= 1.3 $^\circ\text{C/W}$
From mounting base to heatsink	$R_{th\ mb-h}$	= 0.5 $^\circ\text{C/W}$

¹⁾ To ensure thermal stability: $R_{th\ j-a} < 2.5\text{ }^\circ\text{C/W}$ (continuous reverse voltage) or $< 5\text{ }^\circ\text{C/W}$ (a.c.).
For smaller heatsinks T_j max should be derated. For a.c. see page 5.
For continuous reverse voltage: if $R_{th\ j-a} = 5\text{ }^\circ\text{C/W}$, then T_j max = 135 $^\circ\text{C}$.
if $R_{th\ j-a} = 10\text{ }^\circ\text{C/W}$, then T_j max = 120 $^\circ\text{C}$.

CHARACTERISTICS

	BYX30-200(R)	300(R)	400(R)	500(R)	600(R)	
<u>Forward voltage</u>						
$I_F = 50 \text{ A}; T_j = 25 \text{ }^\circ\text{C}$	$V_F < 3.2$	3.2	3.2	3.2	3.2	V ¹⁾
<u>Reverse breakdown voltage</u>						
$I_R = 5 \text{ mA}; T_j = 25 \text{ }^\circ\text{C}$	$V_{(BR)R} > 250$	375	500	625	750	V
	< 1050	1050	1050	1050	1050	V
<u>Reverse current</u>						
$V_R = V_{RWMmax}; T_j = 125 \text{ }^\circ\text{C}$	$I_R < 4.0$	4.0	4.0	4.0	4.0	mA

Reverse recovery charge when switched from

$I_F = 2 \text{ A to } V_R \geq 30 \text{ V};$ $\text{with } -dI_F/dt = 100 \text{ A}/\mu\text{s}; T_j = 25 \text{ }^\circ\text{C}$	$Q_S < 0.70$	μC
--	--------------	---------------

Reverse recovery time when switched from

$I_F = 1 \text{ A to } V_R \geq 30 \text{ V};$ $-dI_F/dt = 50 \text{ A}/\mu\text{s}; T_j = 25 \text{ }^\circ\text{C}$	$t_{rr} < 200$	ns
--	----------------	----

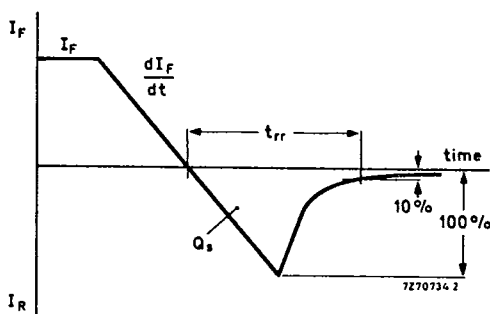

OPERATING NOTES

1. Square-wave operation

When I_F has been flowing sufficiently long for the steady state to be established, there will be a charge due to minority carriers present. Before the device can block in the reverse direction this charge must be extracted. This extraction takes the form of a reverse transient (see figure above). The majority of the power dissipation due to the reverse transient occurs during fall time as the rectifier gradually becomes reverse biased, and the mean power will be proportional to the operating frequency. The mean value of this power loss can be derived from the graphs on page 10.

¹⁾ Measured under pulse conditions to avoid excessive dissipation.

BYX30
SERIES

T-03-17

OPERATING NOTES (continued)

2. Sine wave operation

Power loss in sine wave operation will be considerably less owing to the much slower rate of change of the applied voltage (and consequently lower values of I_{RRM}), so that power loss due to reverse recovery may be safely ignored for frequencies up to 20 kHz.

3. Determination of the heatsink thermal resistance

Example:

Assume a diode, used in an inverter.

frequency	f	=	20	kHz
duty cycle	δ	=	0.5	
ambient temperature	T_{amb}	=	45	$^{\circ}C$
switched from	I_F	=	12	A
to	V_R	=	400	V
at a rate	$-\frac{dI}{dt}$	=	20	A/ μs

At a duty cycle $\delta = 0.5$ the average forward current $I_{FAV} = 6$ A.

From the upper graph on page 5 it follows, that at $I_{FAV} = 6$ A the average forward power + average leakage power = 15 W (point A).

The additional power losses due to switching-off can be read from the nomogram on page 10 (the example being based on optimum use, i.e. $T_j = 150$ $^{\circ}C$). Starting from $I_F = 12$ A on the horizontal scale trace upwards until the appropriate line $-\frac{dI}{dt} = 20$ A/ μs . From the intersection trace horizontally to the right until the

line for $f = 20$ kHz. Then trace downwards to the line $V_R = 400$ V and ultimately trace horizontally to the left and on the vertical axis read the additional average power dissipation $P_{RAV} = 4$ W.

Therefore the total power dissipation $P_{tot} = 15$ W + 4 W = 19 W (point B of the upper graph on page 5). From the right hand part follows the thermal resistance, required at $T_{amb} = 45$ $^{\circ}C$.

$$R_{th\ mb-a} \approx 4\ ^{\circ}C/W$$

The contact thermal resistance $R_{th\ mb-h} = 0.5$ $^{\circ}C/W$.

Hence the heatsink thermal resistance should be:

$$R_{th\ h-a} = R_{th\ mb-a} - R_{th\ mb-h} = (4 - 0.5)\ ^{\circ}C/W = 3.5\ ^{\circ}C/W.$$

**BYX30
SERIES**

T-03-17

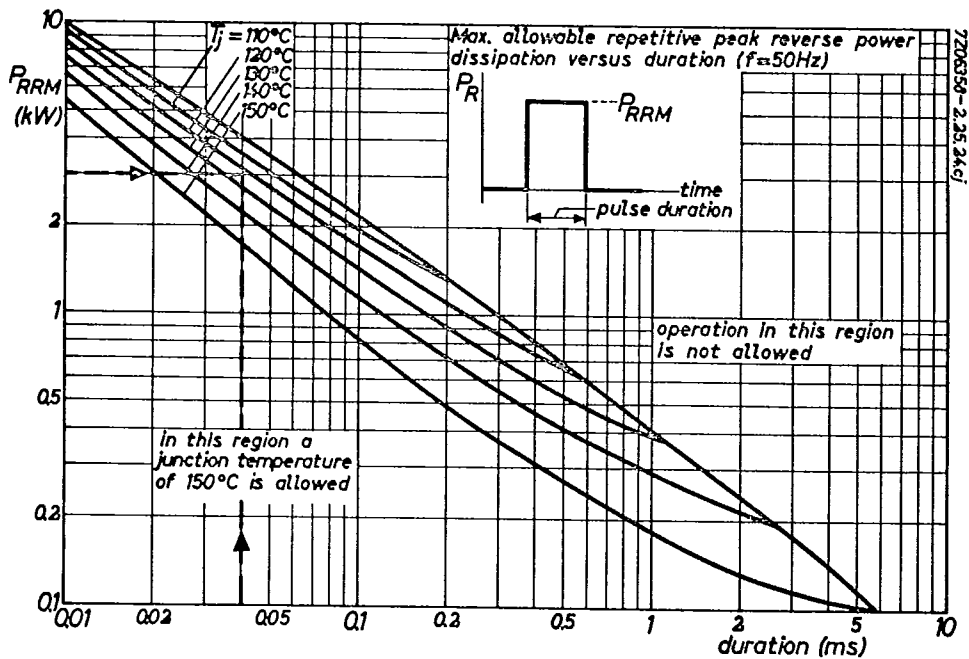
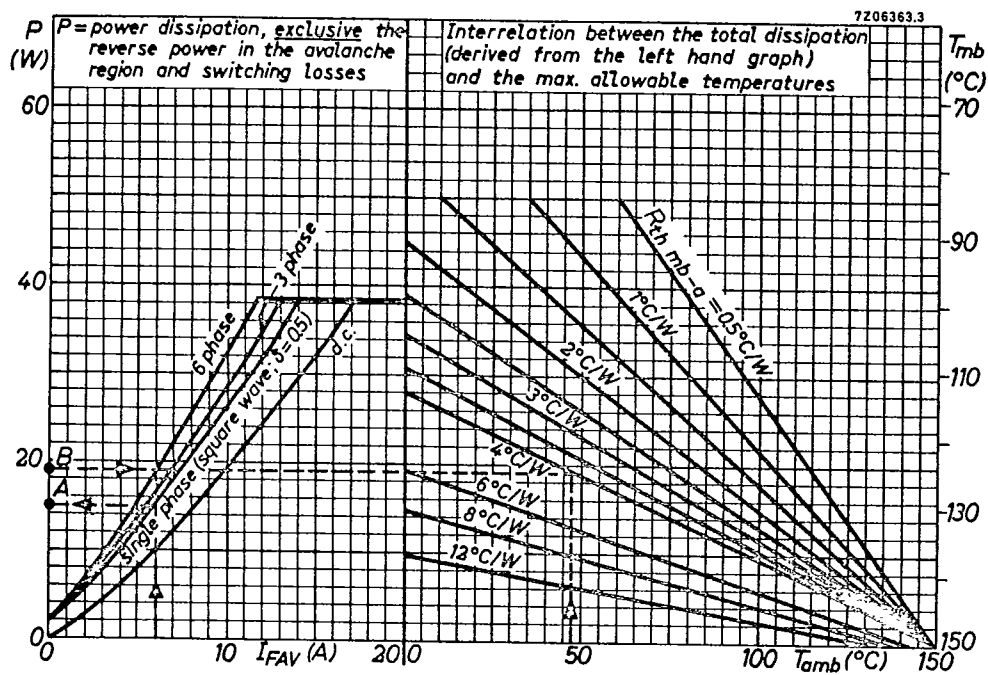

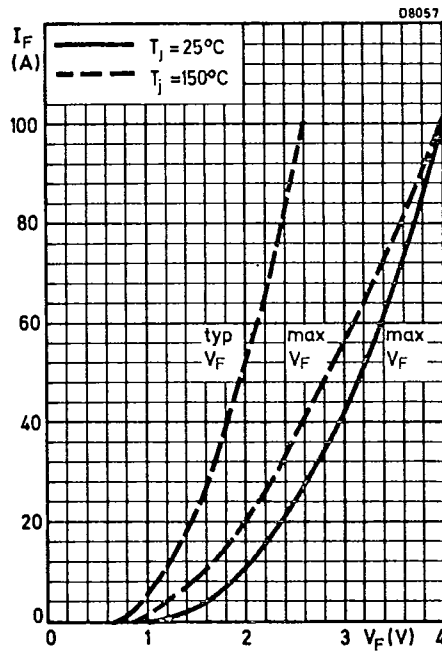
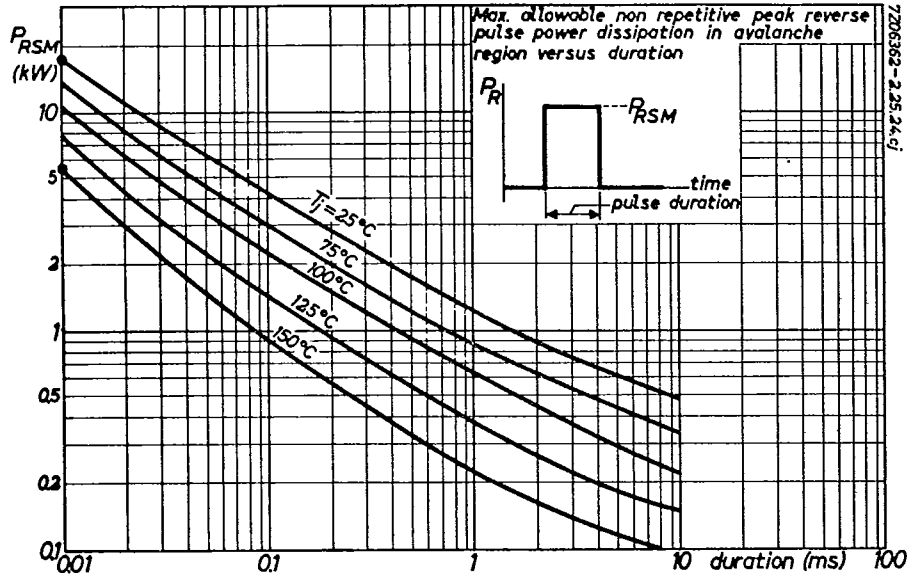

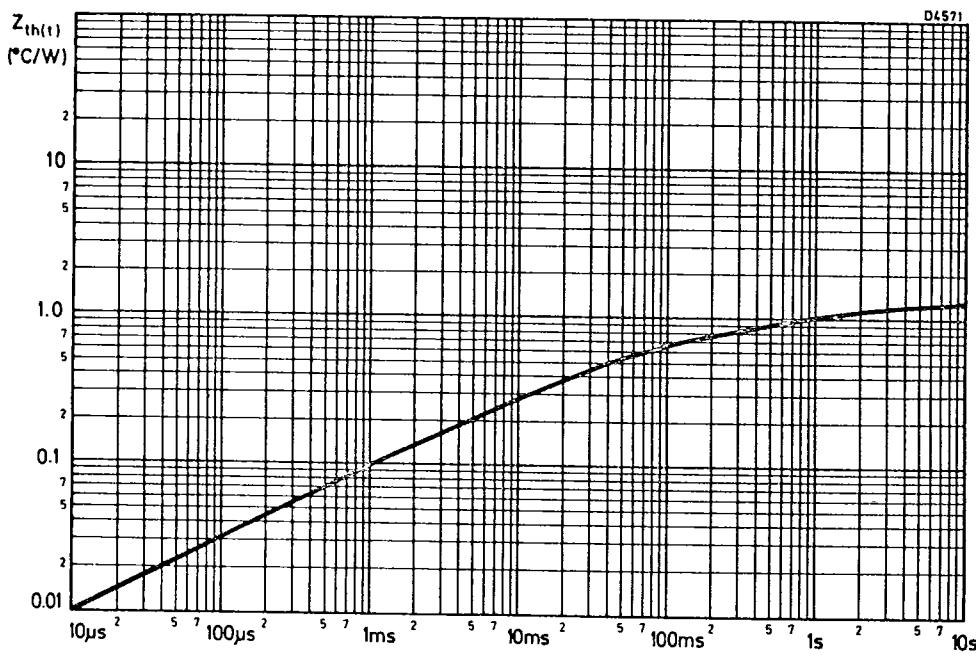
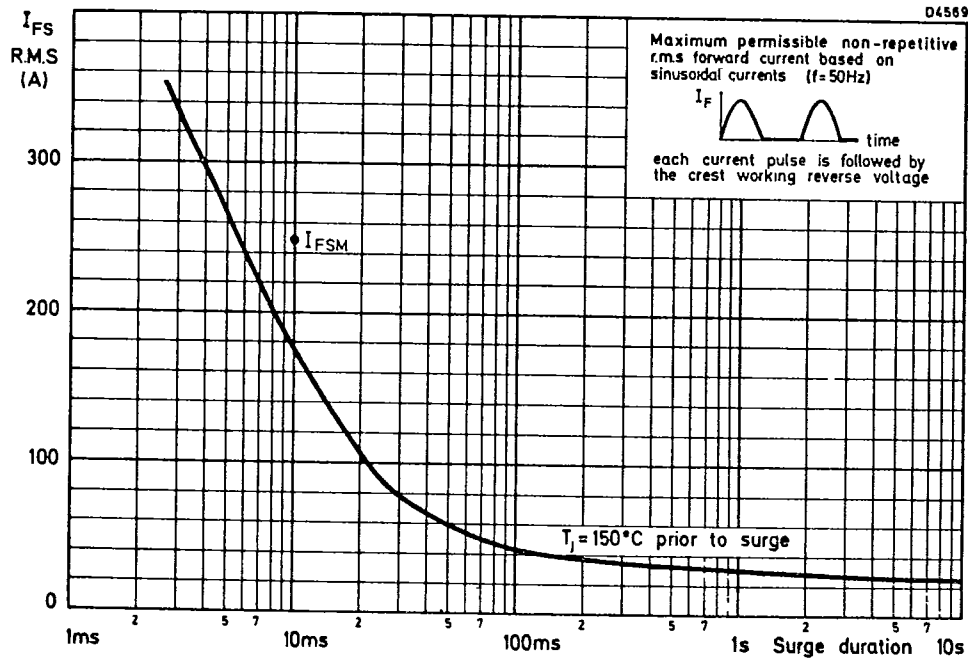

BYX30
SERIES

T-03-17

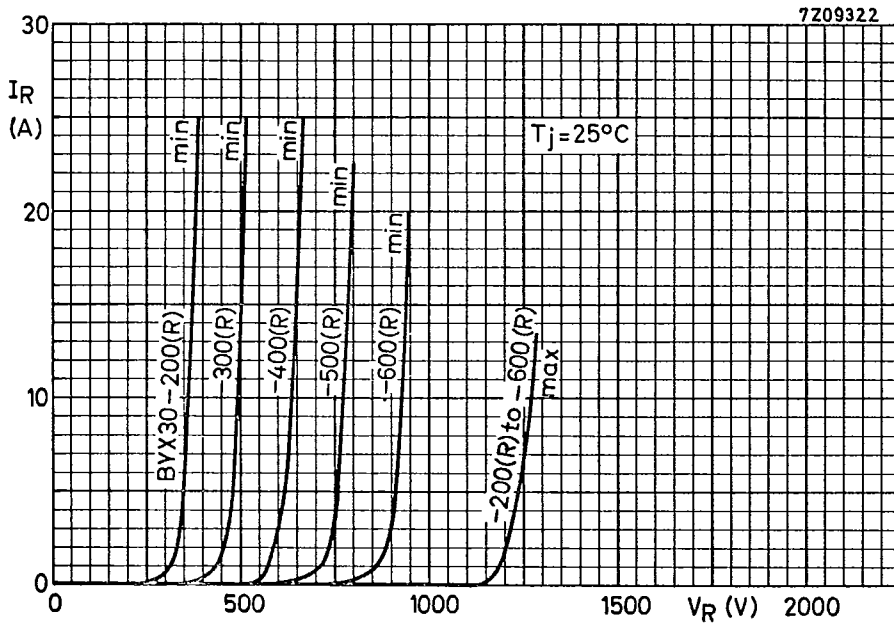
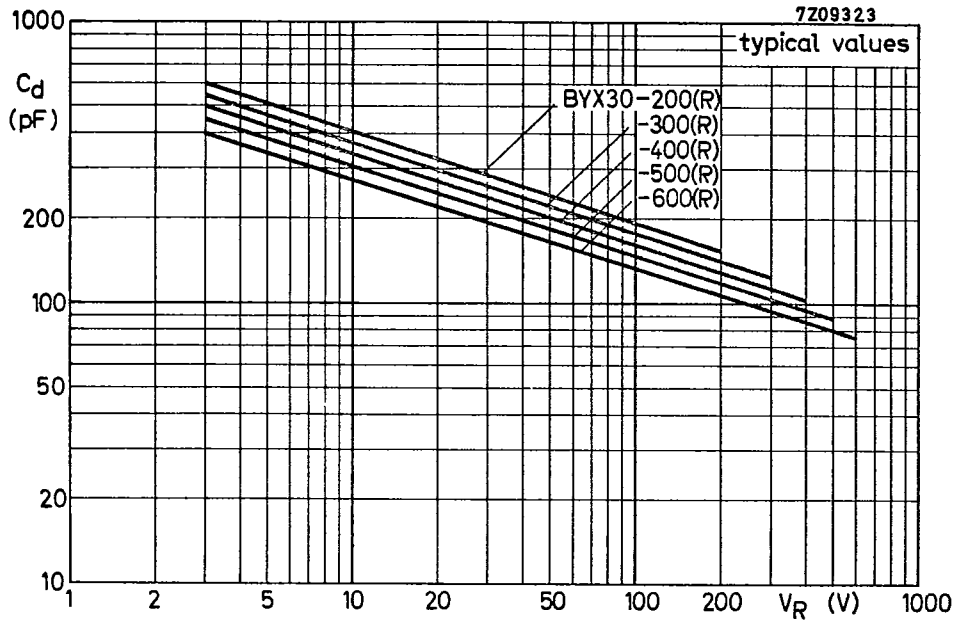

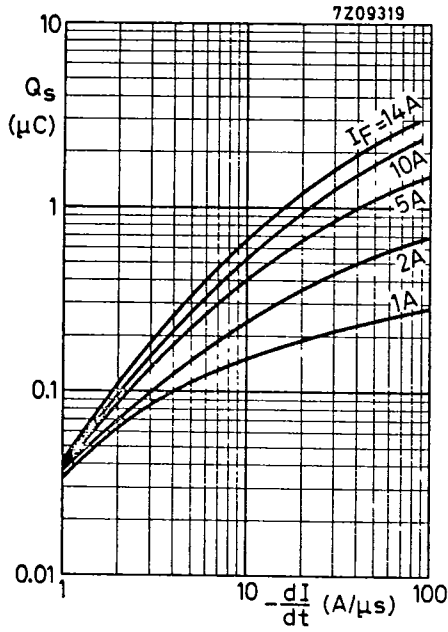

Maximum values; $T_j = 25^\circ\text{C}$; switched from I_F to $V_R \geq 30\text{V}$.

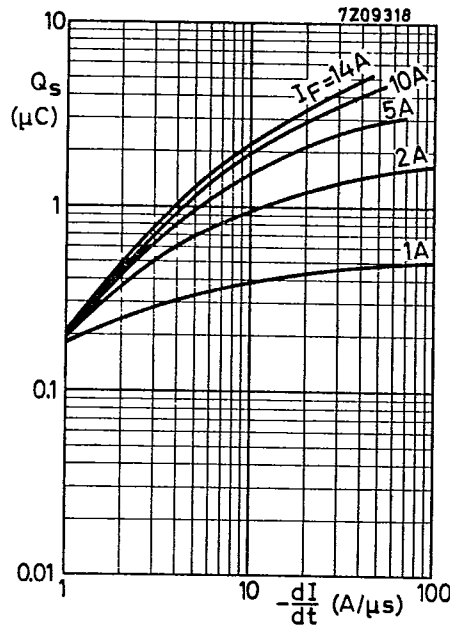

Maximum values; $T_j = 150^\circ\text{C}$; switched from I_F to $V_R \geq 30\text{V}$.

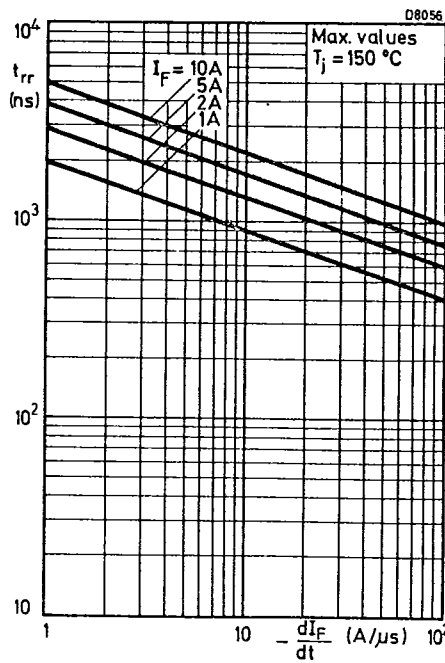
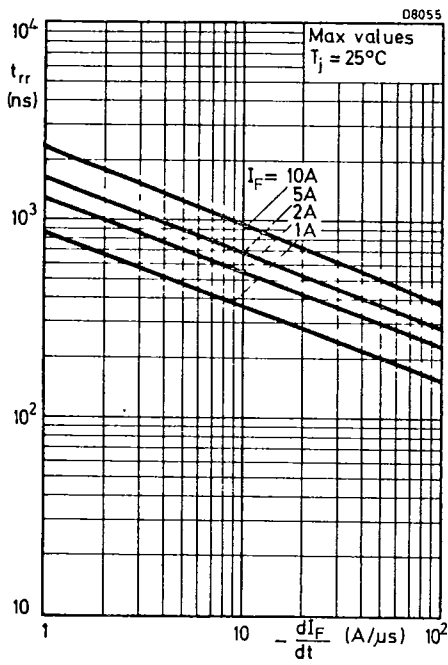

BYX30
SERIES

T-03-17

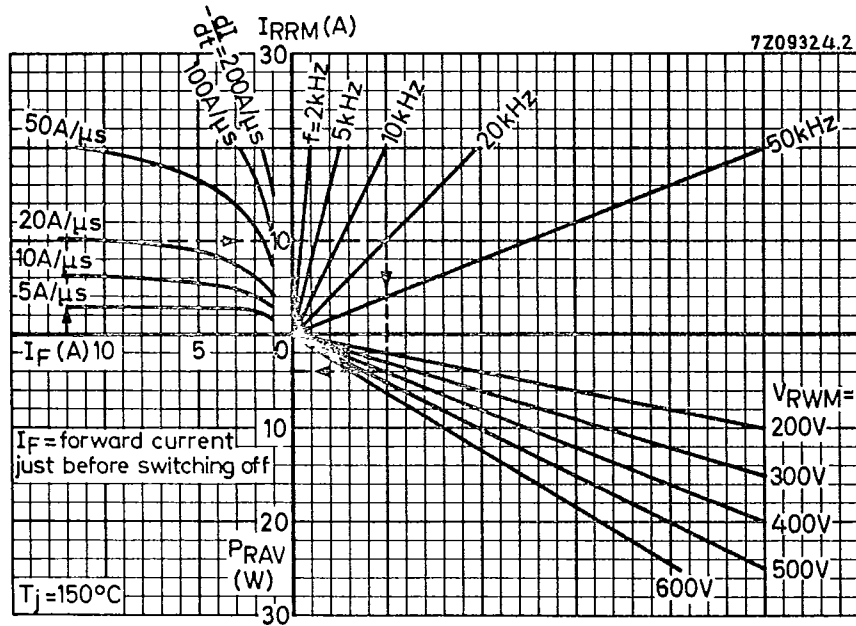
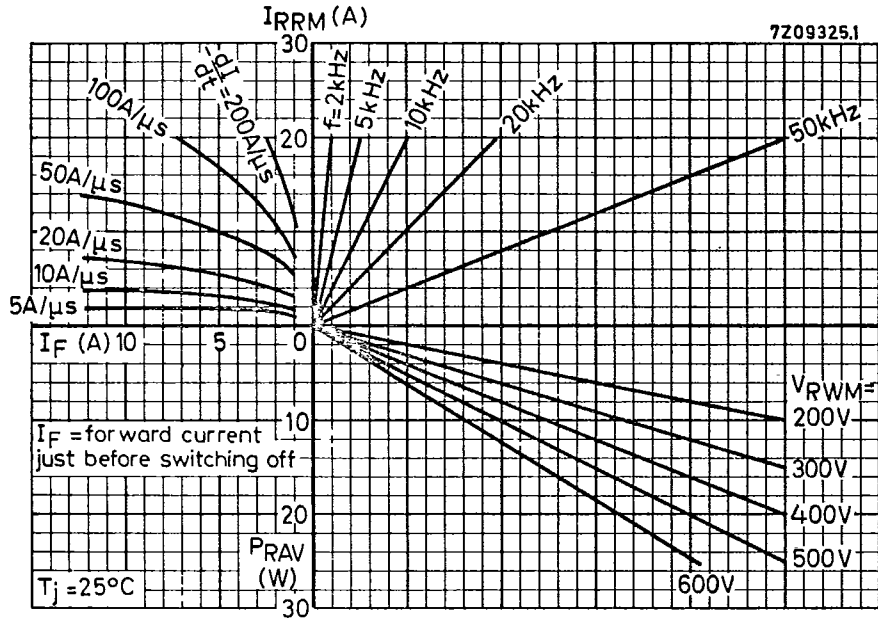

Nomogram: Power loss P_{RAV} due to switching only (square wave operation)