

The Data Book Project

DatasheetArchive.com has launched an ambitious effort to digitize thousands of obsolete data books and technical manuals, making them searchable via the DatasheetArchive website.

Scroll down to see the scanned document.

Silicon rectifier diodes and bridge modules

fast recovery rectifier diodes

book 1 part 4

Type No.	Outline Drawing reference	RATINGS $I_{F(AV)}$ (A)	V_{RRM} (V)	V_{RWM} (V)	I_{FRM} (A)	I_{FSM}^1 (A)	$I^2 t$ $t = 10ms$ (A ² s)	t_{rr} max. (ns)	CHARACTERISTICS		
									V_F at I_F max. ²⁾ (V)	I_F (A)	I_R max. ³⁾ (mA)
BY223	SOD-38 O	5*	1500	1500	10	20	—	—	2.3	20	0.6
†BYW19 — 800 — 1000	SOD-38 O	7	800 1000	800 800	20	40	—	450	2.3	20	0.6
BYW29 — 50 — 100 — 150	— BF3	7	50 100 150	50 100 150	80	80	32	35	0.85	5	1 ⁴⁾
§†BYX50 — 200 — 300	DO-4 B1	7	200 300	200 300	80	80	32	100	1.95	20	3
†BYX71 — 350 — 600	SOD-38 O	7	350 600	300 500	25	60	—	450	1.25	5	0.4
BY277 — 600R — 750R	SOD-38 O	10*	600 750	500 600	20	50	—	1000	1.55	20	0.3
†1N3889 †1N3890 †1N3891 †1N3892	DO-4 B1	12	50 100 200 300	50 100 200 300	125	125	78	200	1.4	12	3
BYW30 — 50 — 100 — 150	DO-4 B1 (M5 stud)	12	50 100 150	50 100 150	200	200	200	35	0.85	10	3 ⁴⁾
§†BYX30 — 200 — 300 — 400 — 500 — 600	DO-4 B1	14	200 300 400 500 600	200 300 400 500 600	310	250	312	350	3.2	50	4
†BYX46 — 200 — 300 — 400 — 500 — 600	DO-4 B1	22	200 300 400 500 600	200 300 400 500 600	400	300	450	350	2.0	50	4
BYW31 — 50 — 100 — 150	DO-4 B1 (M5 stud)	25	50 100 150	50 100 150	320	320	500	50	0.85	20	5 ⁴⁾

avalanche rectifiers

Type No.	Outline Drawing reference	RATINGS $I_{F(AV)}$ (A)	V_{RWM} (V)	I_{FRM} (A)	I_{FSM}^1 (A)	$I^2 t$ $t = 10ms$ (A ² s)	P_{RRM} $t = 10\mu s$ (kW)	R_{RSM} $t = 10\mu s$ (kW)	CHARACTERISTICS		
									V_F at I_F max. ²⁾ (V)	I_F (A)	I_R max. ³⁾ (mA)
§BYX45 — 600R — 800R — 1000R	DO-1 A1	1.5	600 800 1000	15	40	—	0.8	2.5	1.45	5	0.1
†BYX39 — 600 — 800 — 1000	DO-4 B1	9.5	600 800 1000	100	100	50	2	4	1.7	20	0.3
†BYX40 — 600 — 800 — 1000	DO-4 B1	12	600 800 1000	250	200	—	3.5	8	2.5	50	0.3
§†BYX25 — 600 — 800 — 1000	DO-4 B1	20	600 800 1000	440	550	1500	3	18	1.8	50	1.0 0.8 0.6
†BYX56 — 600 — 800 — 1000	DO-5 C1	47	600 800 1000	450	800	3200	6.5	6.5	1.8	150	1.6

¹⁾ At $T_j = T_j \text{ max.}$ ²⁾ At $T_j = 25^\circ\text{C}$ ³⁾ At $T_j \geq 125^\circ\text{C}$ ⁴⁾ At $T_j = 100^\circ\text{C}$ * Peak currents

† Reverse polarity types (stud-anode) are available. These are denoted by the final letter R, e.g. BYX50-200R

§ Also available to BS9000 (see page 7)

OUTLINES and DIMENSIONS (millimetres)

A

B.S.3934 SO-16

DO-1
DO-2
DO-3

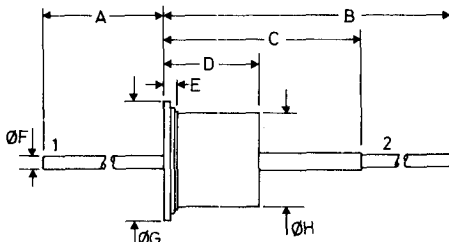

	1	2	A	B	C	D	E	ØF	ØG	ØH
	min.	min.	min.	min.	min.	max.	max.	max.	max.	max.
A1	a	k	35	51	17	7.7	1.6	1.1	9.6	7.1
A2	k	a	35	49	17	8.5	1.9	1.1	9.7	7.1
A3	k	a	35	51	17	7.7	1.6	1.1	9.6	7.1

B

B.S.3934 SO-10

DO-4

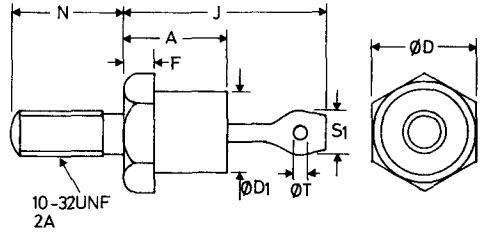

A 10.3 max.
ØD 11.1 max.
ØD1 9.3 max.
F 3.2

J 20.3 max.
N 11.5 max.
S1 4.8 max.
ØT 1.6 min.

	Stud	Eyelet
B1	k	a
B2	a	k

C

B.S.3934 SO-13

DO-5

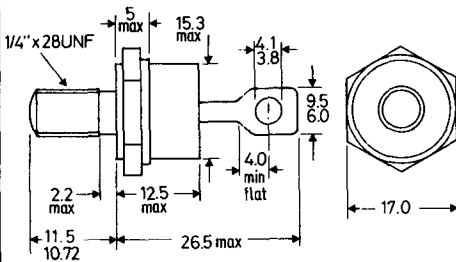

	Stud	Eyelet
C1	k	a
C2	a	k

D

DO-7
DO-14
DO-15

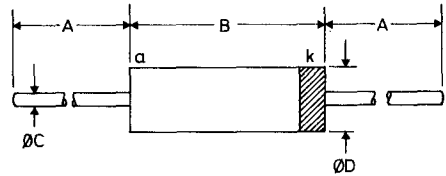

		A	B	ØC	ØD
		min.	max.	nom.	max.
D1	DO-7	25.4	7.6	0.52	2.5
D2	DO-14	25.4	7.6	0.5	3.3
D3	DO-15	25.4	6.4	0.8	3.2

E

DO-22
SOD-47

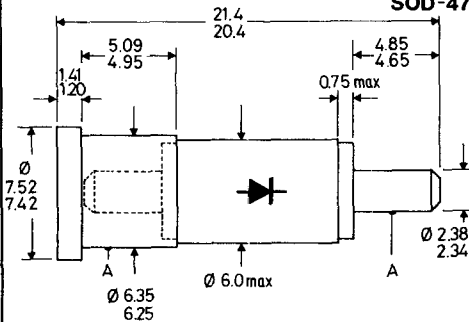

A = concentricity tolerance = ± 0.20

F

DO-30

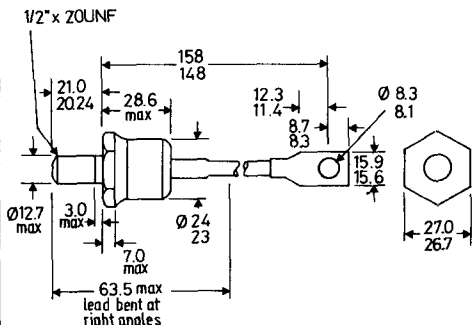

BZW86 Blue sleeve - anode to eyelet
BZW86R Red sleeve - anode to stud

These drawings give limited information for quick reference purposes. For equipment design more complete information should be obtained from individual data sheets in the Technical Handbook or from standard B.S. or JEDEC outline drawings.

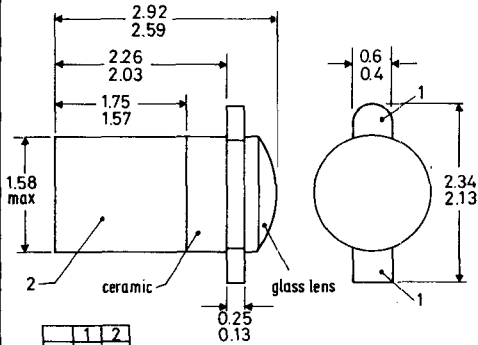
G**DO-31**

	1	2
G1	k	a
G2	e	c

For LED's the overall length = 3.60/2.97

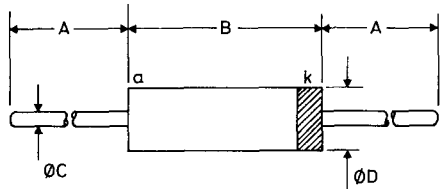
H**DO-35**

A	B	ØC	ØD
min.	max.	max.	max.
25.4	4.25	0.56	1.85

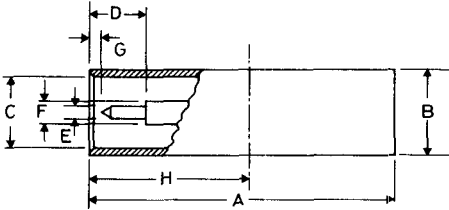
J**DO-37
SOD-49**

A	19.43/18.67	ØE	0.84/0.79
ØB*	5.59/5.49	ØF	1.57/1.52
ØC	4.80/4.72	G	0.71/0.15
D	3.73 min.	H	10.32 nom.

*These tolerances apply only over H

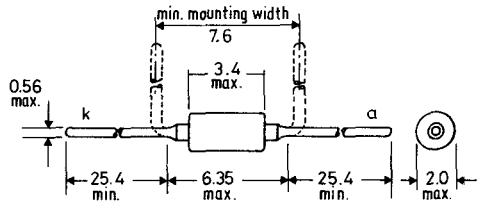
K**SOD-17**

Cathode indicated by the broad band of colour code

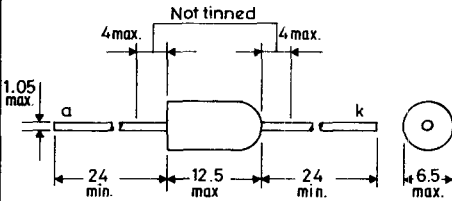
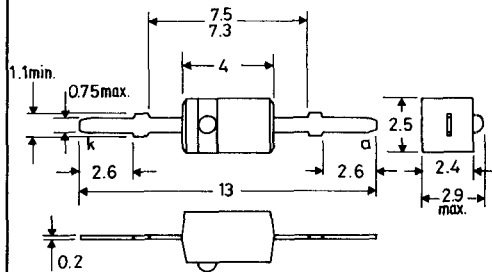
L**SOD-18****M****SOD-23**

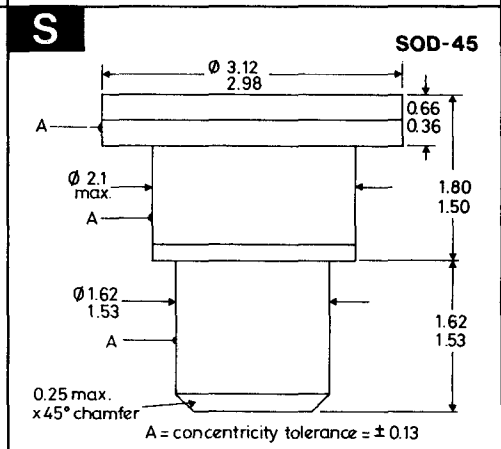
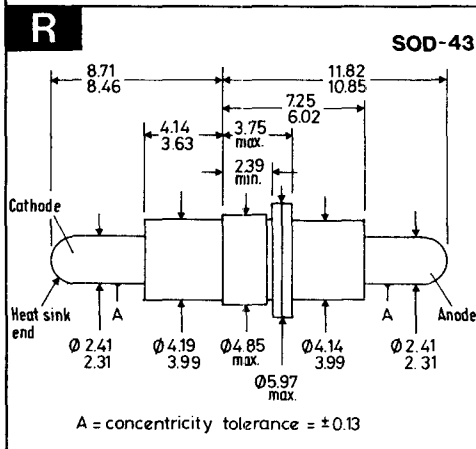
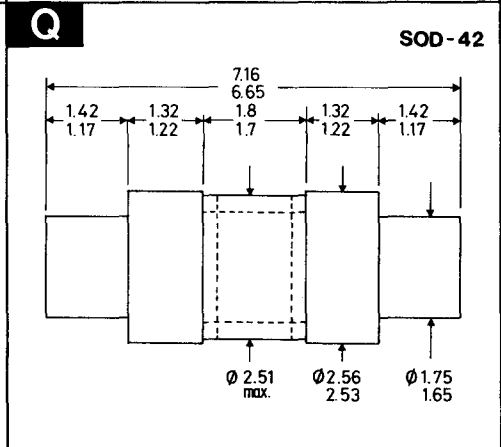
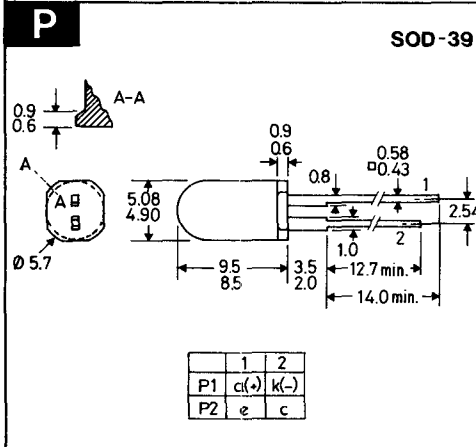
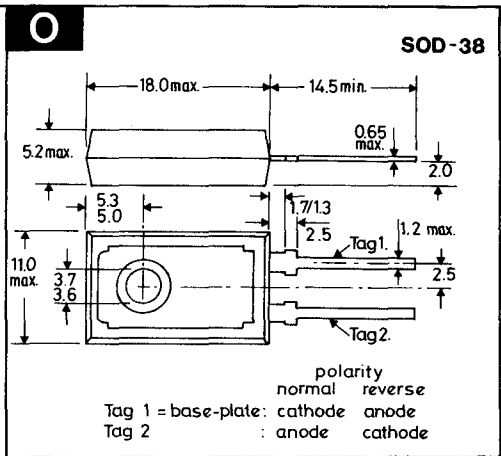
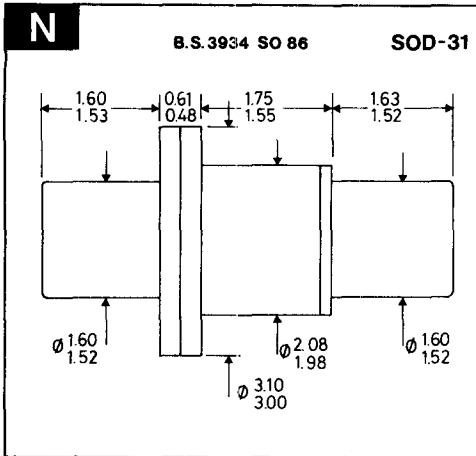

These drawings give limited information for quick reference purposes. For equipment design more complete information should be obtained from individual data sheets in the Technical Handbook or from standard B.S. or JEDEC outline drawings.

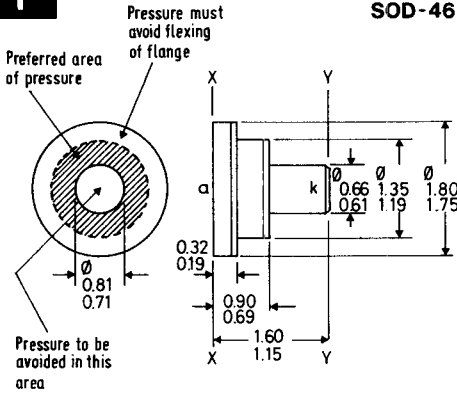
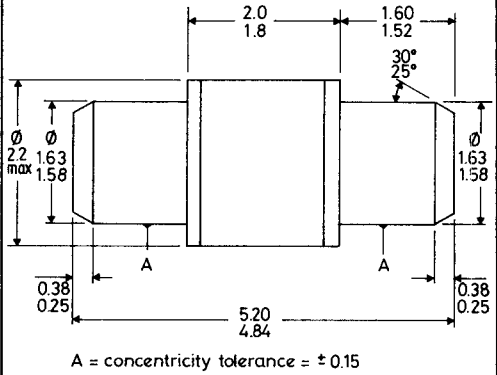
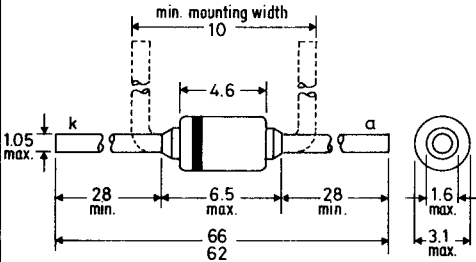
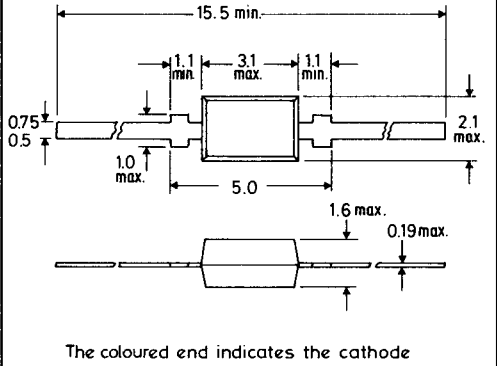
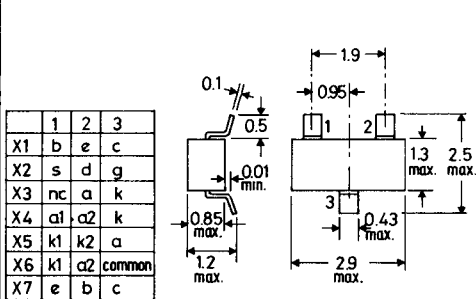
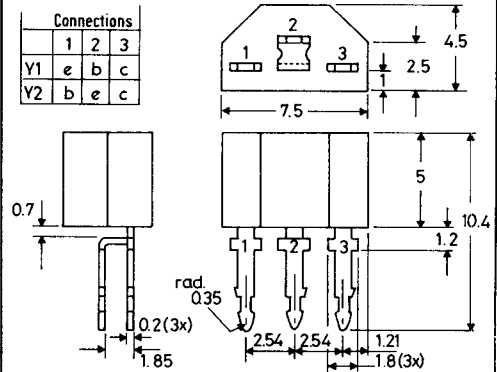
T**SOD-46****U****SOD-50****V****SOD-51****W****SOD-52****X****SOT-23****Y****SOT-25**

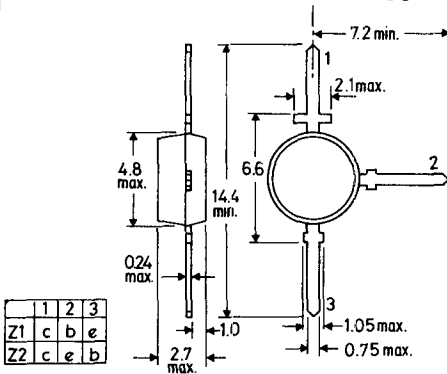
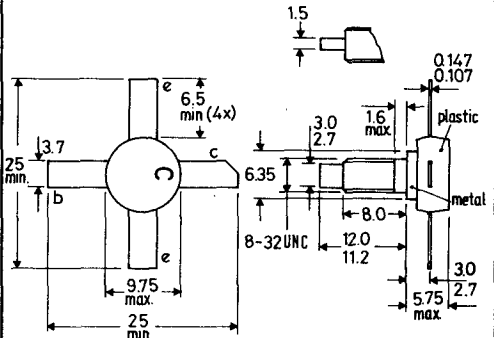
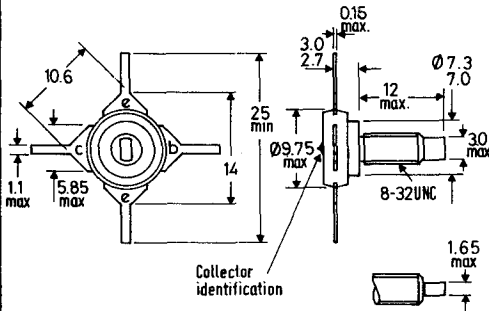
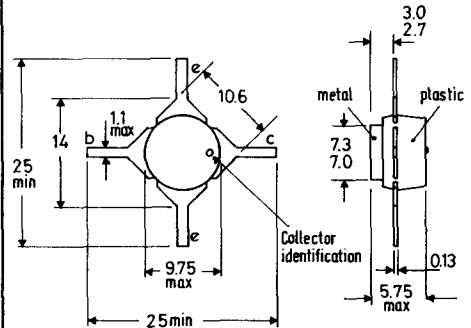
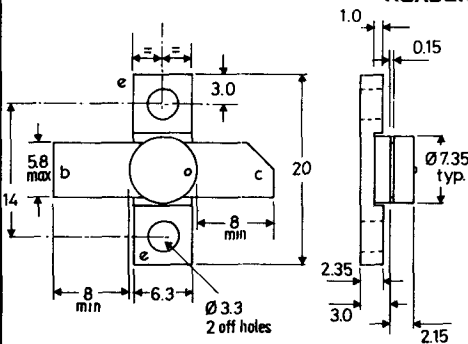
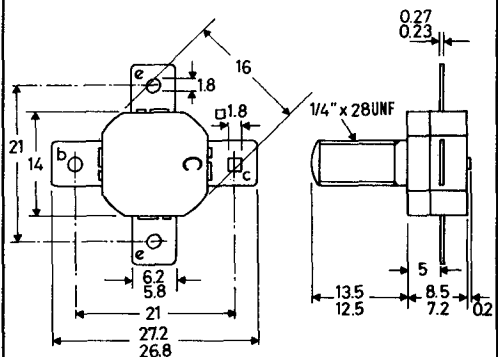
Z**SOT-37****AC****SOT-48/2****AD****SOT-48/3****AE****SOT-48/4****AF****SOT-48
HEADER****AG****SOT-55**

These drawings give limited information for quick reference purposes. For equipment design more complete information should be obtained from individual data sheets in the Technical Handbook or from standard B.S. or JEDEC outline drawings.

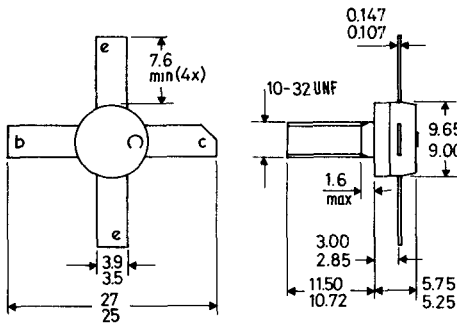
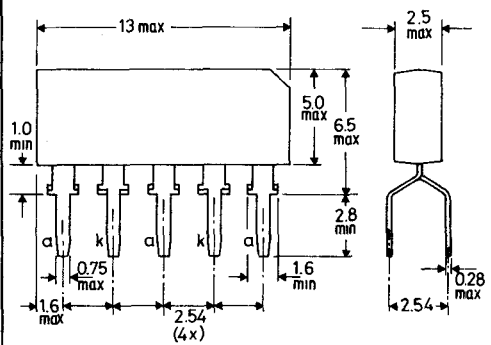
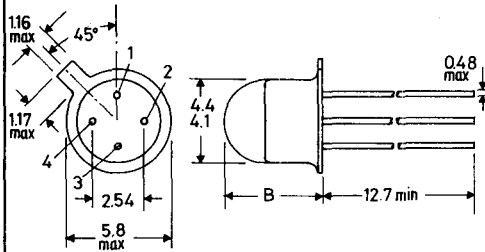
AH**SOT-56****AJ****SOT-60****AK****SOT-70**

	1	2	3	4	B max
AK1	a	—	k	—	5.08
AK2	e	b	c	—	4.5
AK3	Vp	IP	GND	OP	5.08

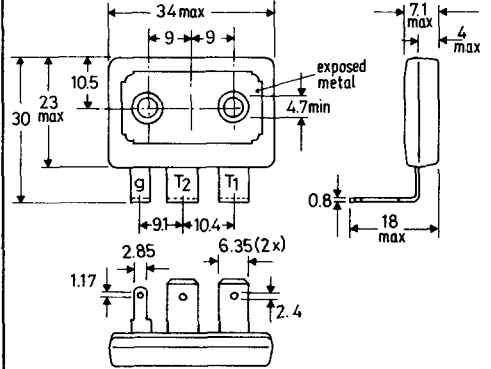
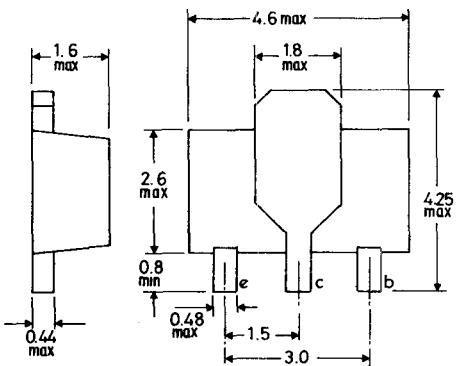
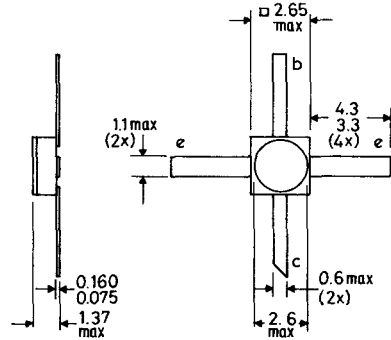
AL**SOT-80****AM****SOT-89****AN****SOT-100**

AO

SOT-103

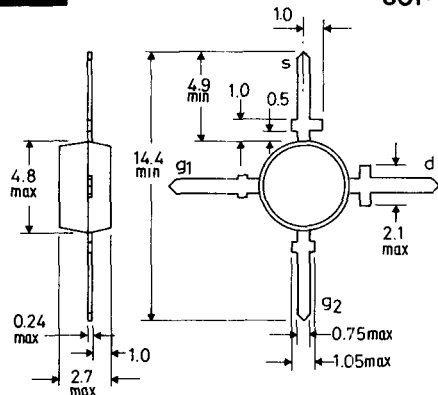

AP

SOT-105

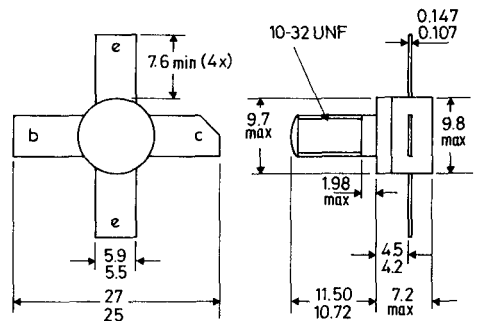

AQ

B.S.3934 SO-21/SB3-10 TO-1

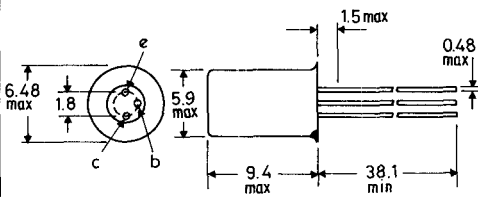

AR

B.S.3934 SO-5B/SB2-2 TO-3

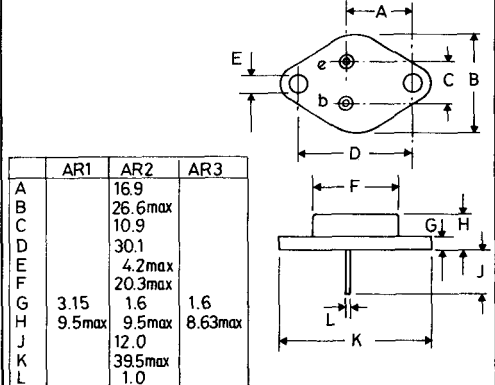

AS

B.S.3934 SO-3/SB3-3B TO-5

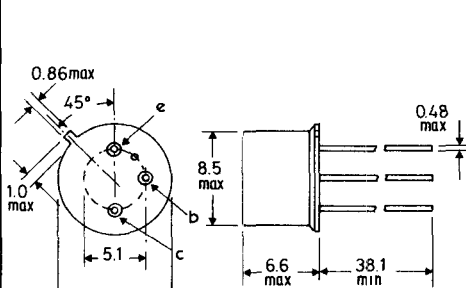

AS1: collector connected to case
AS2: base connected to case

AT

B.S.3934 SO-12A/SB3-6A TO-18

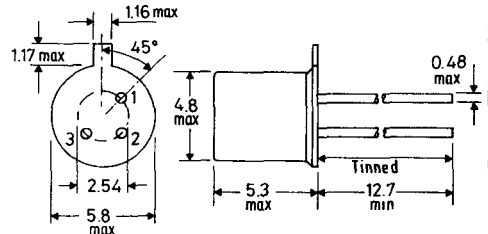

	1	2	3
AT1	e	b	c + env.
AT2	s	d	g + env.
AT3	d	g	s + env.
AT4	k	-	a
AT5	a	-	k
AT6	k	-	a

These drawings give limited information for quick reference purposes. For equipment design more complete information should be obtained from individual data sheets in the Technical Handbook or from standard B.S. or JEDEC outline drawings.

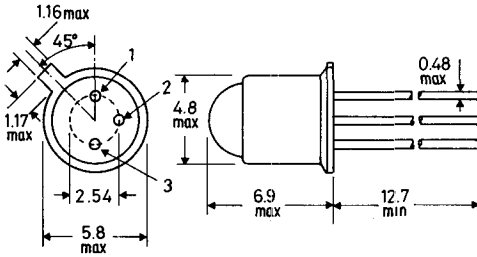
AU**TO-18**
(with lens)

	1	2	3
AU1	a	a	k
AU2	e	b	c+case
AU3	k	-	a

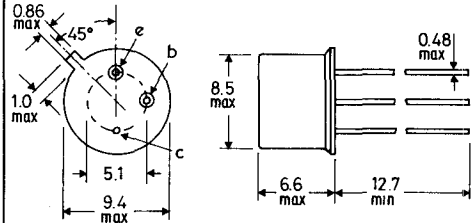
AV**B.S.3934 SO-3/SB3-3A TO-39**

AV1: b+case
 AV2: case isolated
 AV3: c+case
 AV4: e.cathode
 b.gate
 c.anode+case

AV5: e.b. cell connections
 c. metal case
 AV6: red spot indicates
 +ve connection

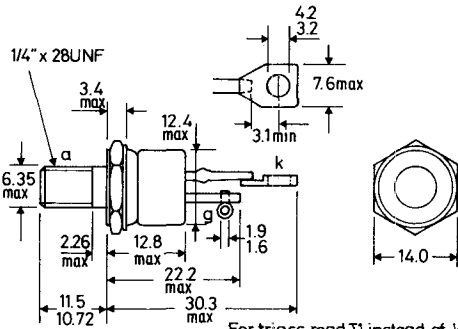
AW**B.S.3932 SO-36 TO-48**

For triacs read T1 instead of k
 T2 instead of a

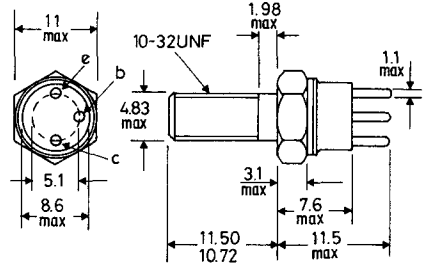
AX**TO-60**

Emitter connected to envelope

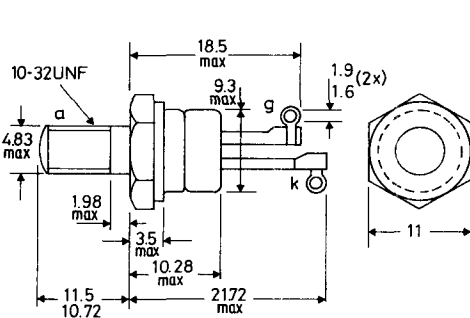
AY**B.S.3934 SO-35A TO-64**

For triacs read T1 instead of k
 T2 instead of a

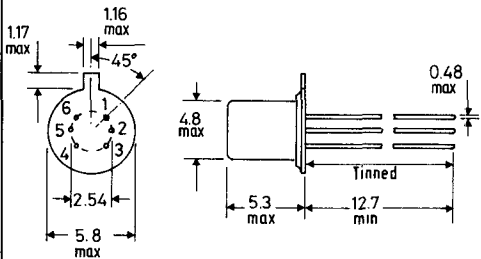
AZ**TO-71**

Pin	1	2	3	4	5	6
AZ1	e1	e2	c2	b2	b1	c1
AZ2	s1	d1	g1	s2	d2	g2

BA

B.S.3934 SO-12A/SB4-3 TO-72

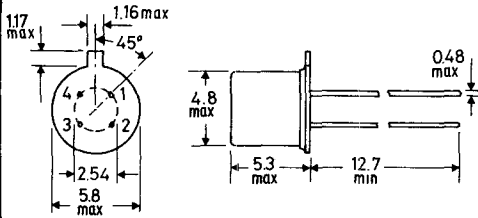

	1	2	3	4
BA1	b	e	c	s+envelope
BA2	e	b	c	s+envelope
BA3	s	d	g	screen+envelope
BA4	d	g	g	s+b+envelope
BA5	d	s	g	b+envelope
BA6	k	gk	ga	a

BBTO-92
variant

Pin	1	2	3
BB1	e	b	c
BB2	b	e	c
BB3	d	s	g
BB4	g	a	k
BB5	b	c	e

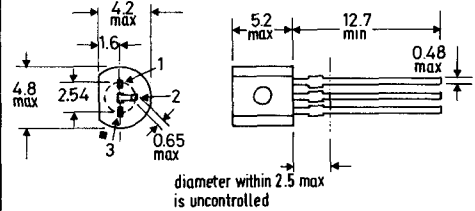
**BC**

B.S.3934 SO-30C TO-94

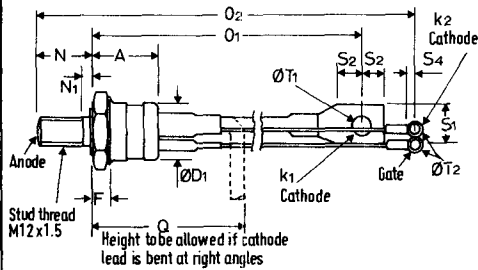

A	28.5max	O1	158 max	S4	3.8 min
ØD1	24.1max	O2	190max	ØT1	8.3max
F	8.9max	Q	63.5max	ØT2	4.2max
N	21.0max	S1	16.5max		
N1	3.0max	S2	9.6min		

BD

TO-103

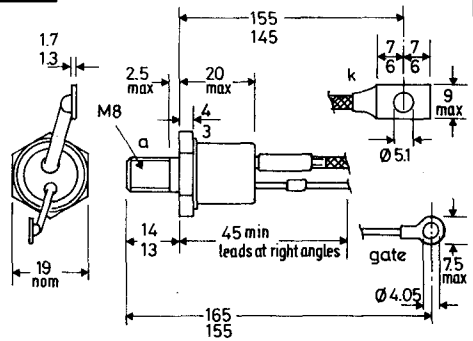
For triacs read T1 instead of k
T2 instead of a**BE**

TO-126

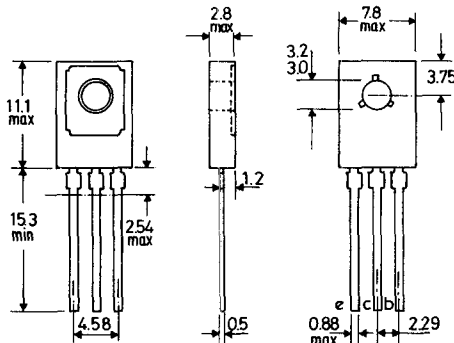
**BF**

TO-220

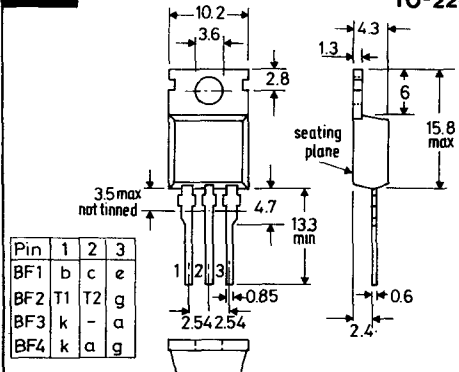

Pin	1	2	3
BF1	b	c	e
BF2	T1	T2	g
BF3	k	-	a
BF4	k	a	g

These drawings give limited information for quick reference purposes. For equipment design more complete information should be obtained from individual data sheets in the Technical Handbook or from standard B.S. or JEDEC outline drawings.

BG

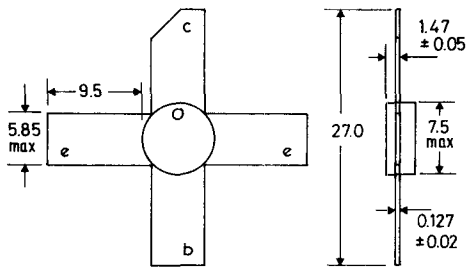

BH

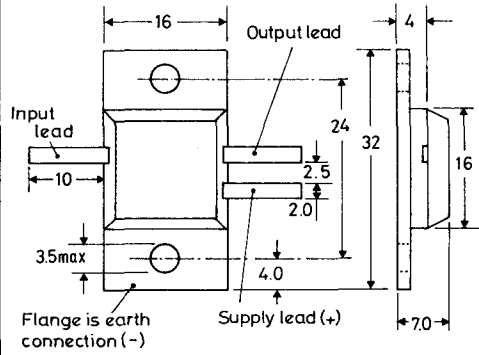

BJ

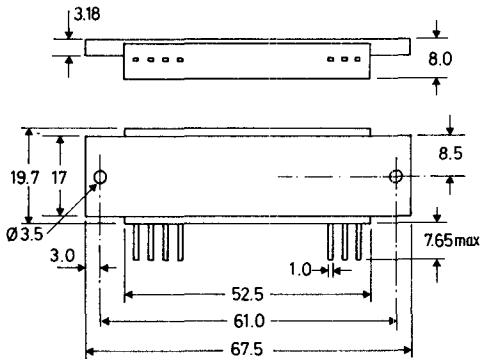

BK

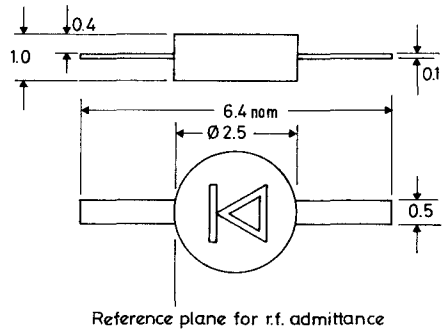

BL

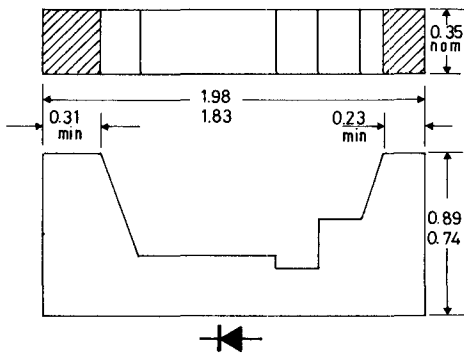

BM

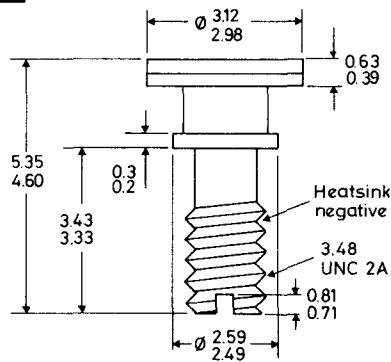

BN

B.S.3934

SO-26

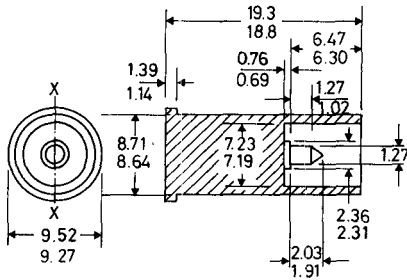

(All dimensions max.)

BO

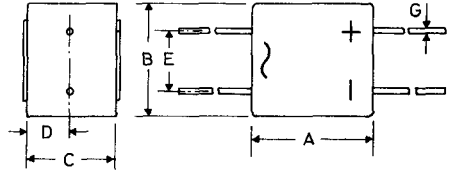

	BO1	BO2	BO3
A	12	20	12
B	10	19	10
C	8	15	8
D	4	7.5	4
E	5	10	5
F	58	60	48
G	0.75	1.0	1.1

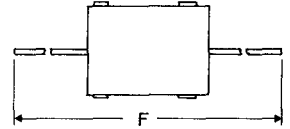

BP

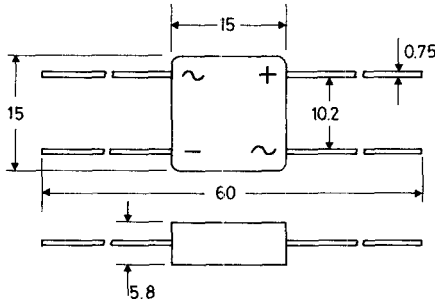

BQ

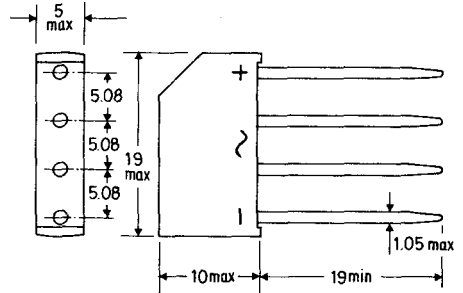

BR

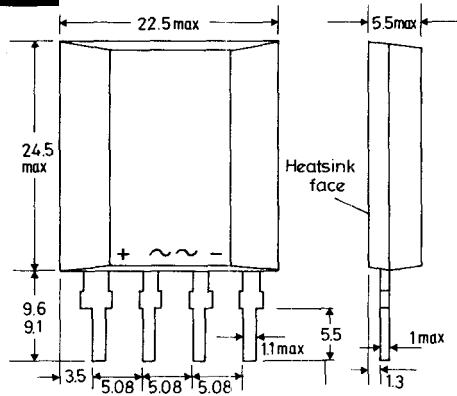

BS

B.S.3934 SO-67

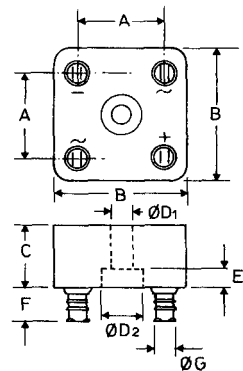

	BS1	BS2
	typ.	max.
A	23	21
B	35	34.6
C	17	15.2
ØD1	5	5.05
ØD2	11	11
E	5	3.7
F	9	9
ØG	4.8	4.8

These drawings give limited information for quick reference purposes. For equipment design more complete information should be obtained from individual data sheets in the Technical Handbook or from standard B.S. or JEDEC outline drawings.

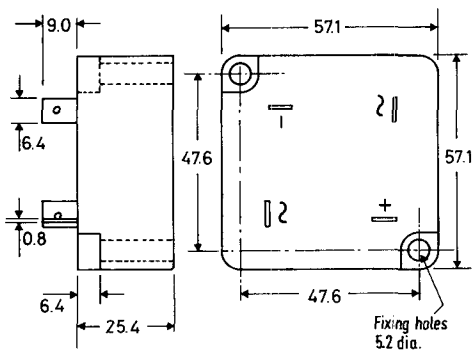
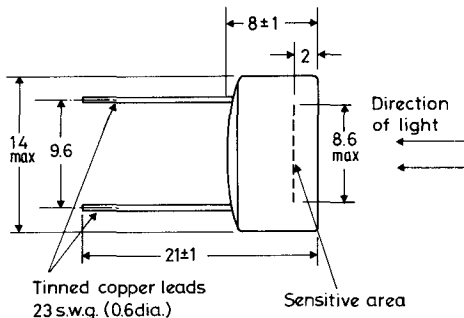
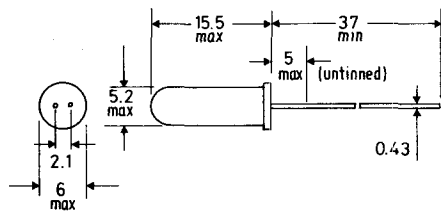
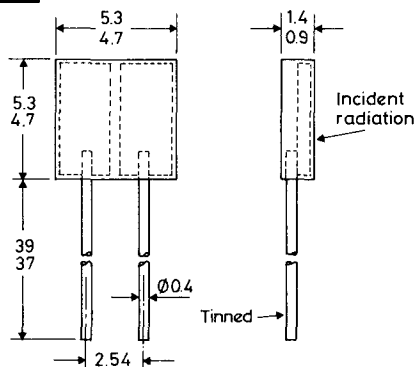
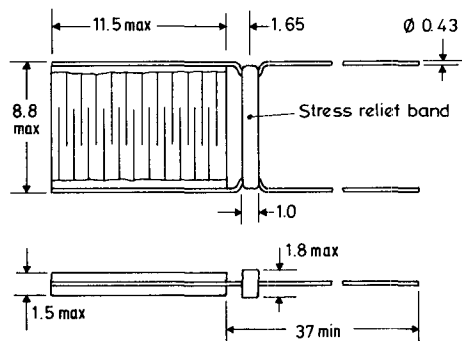
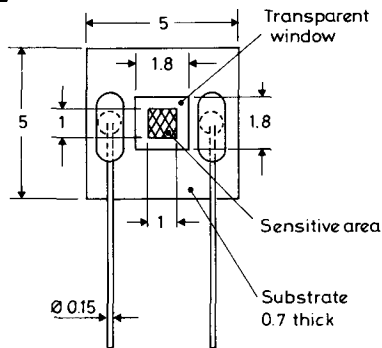
BT**BU****BV****BW****BX****BY**

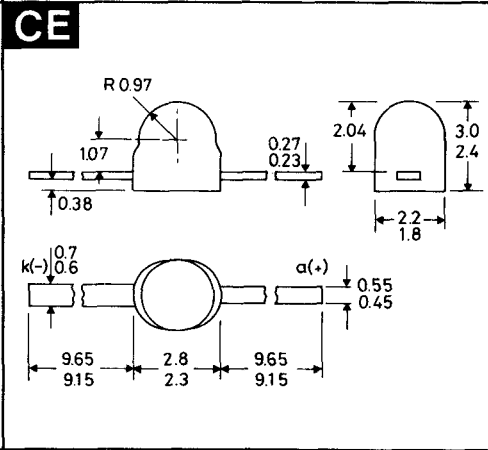
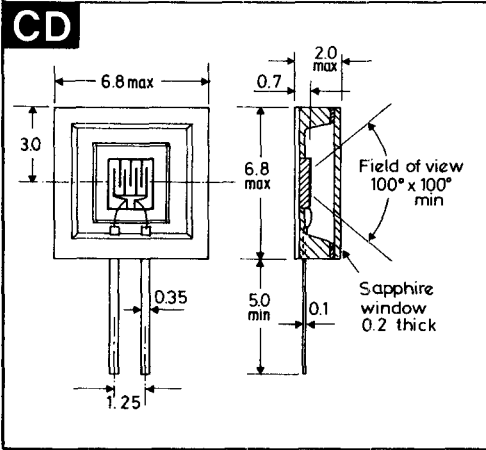
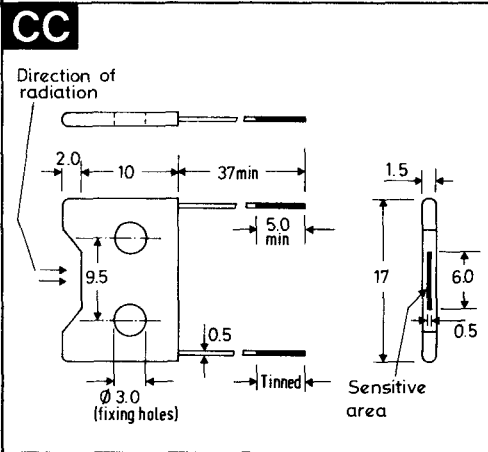
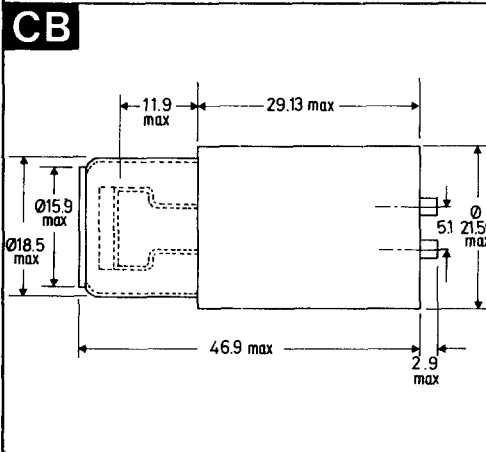
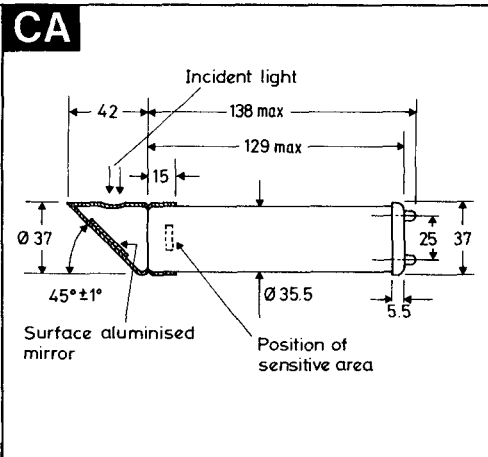
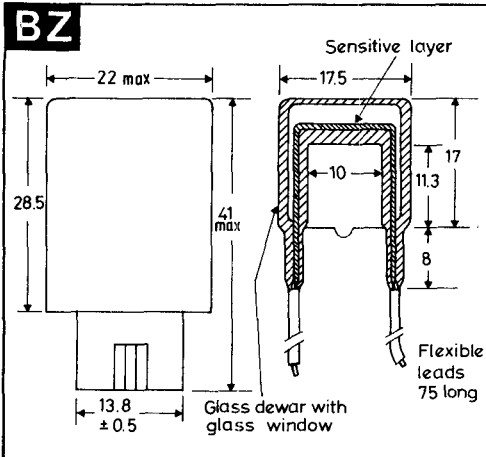

These drawings give limited information for quick reference purposes. For equipment design more complete information should be obtained from individual data sheets in the Technical Handbook or from standard B.S. or JEDEC outline drawings.

CF

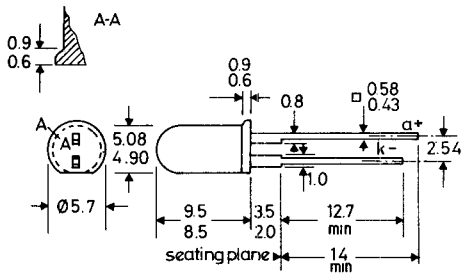

CG

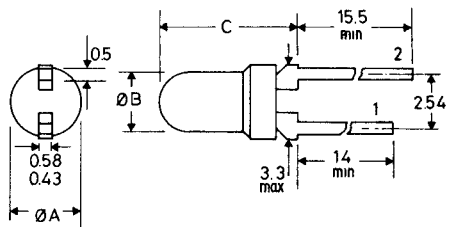

	1	2	$\varnothing A$	$\varnothing B$	C
CG1	k^-	a^+	3.0-3.17	2.4-2.6	5.8-6.3
CG2	a^+	k^-	3.0-3.17	2.4-2.6	5.8-6.3
CG3	k^-	a^+	3.3 max	2.65-3.17	4.8-6.3

CH

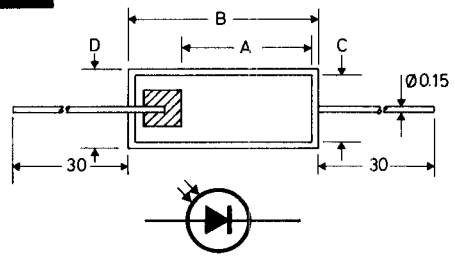

	CH1	CH2
A	2.2	3.5
B	3.35	4.55
C	0.95	1.85
D	1.25	2.15

CJ

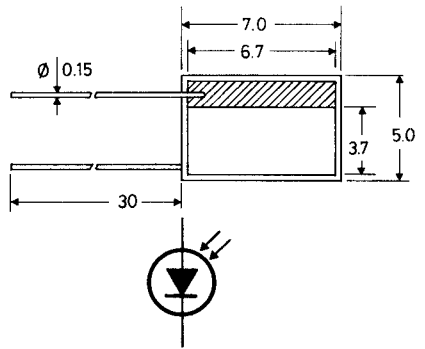

CK

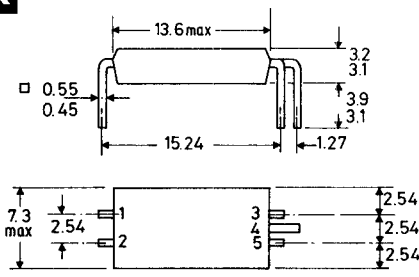

Pin	1	2	3	4	5
CK1	a	k	b	c	e
CK2	k	a	e	omitted	c

CL

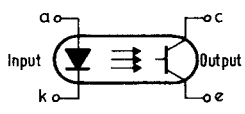
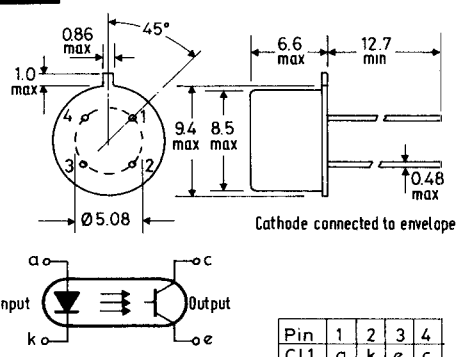

Pin	1	2	3	4
CL1	a	k	e	c
CL2	e	c	a	k

CM

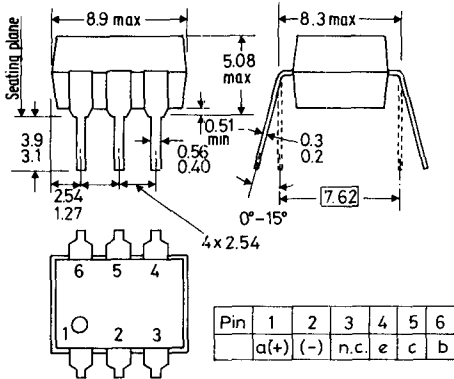

CN

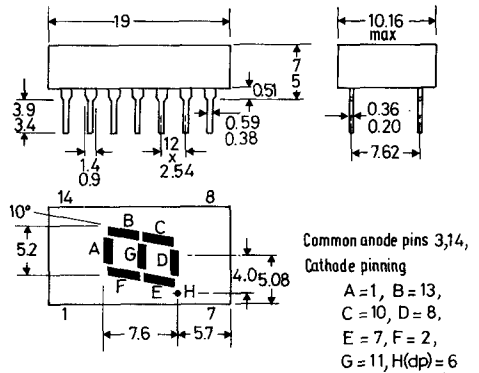

CO

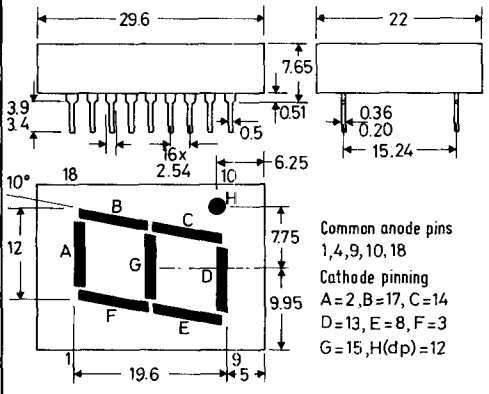

These drawings give limited information for quick reference purposes. For equipment design more complete information should be obtained from individual data sheets in the Technical Handbook or from standard B.S. or JEDEC outline drawings.