

DATA SHEET

TDA8512J

**26 W BTL and 2 × 13 W SE or
4 × 13 W SE power amplifier**

Preliminary specification
File under Integrated Circuits, IC01

2001 Nov 16

**26 W BTL and 2 × 13 W SE or
4 × 13 W SE power amplifier****TDA8512J**

CONTENTS	15	PACKAGE OUTLINE
1 FEATURES	16	SOLDERING
2 APPLICATIONS	16.1	Introduction to soldering through-hole mount packages
3 GENERAL DESCRIPTION	16.2	Soldering by dipping or by solder wave
4 QUICK REFERENCE DATA	16.3	Manual soldering
5 ORDERING INFORMATION	16.4	Suitability of through-hole mount IC packages for dipping and wave soldering methods
6 BLOCK DIAGRAM		
7 PINNING	17	DATA SHEET STATUS
8 FUNCTIONAL DESCRIPTION	18	DEFINITIONS
8.1 Mode select switch	19	DISCLAIMERS
8.2 Mode select		
8.3 Built-in protection circuits		
8.4 Short-circuit protection		
9 LIMITING VALUES		
10 HANDLING		
11 THERMAL CHARACTERISTICS		
12 DC CHARACTERISTICS		
13 AC CHARACTERISTICS		
14 APPLICATION INFORMATION		
14.1 Input configuration		
14.2 Output power		
14.3 Power dissipation		
14.4 Supply Voltage Ripple Rejection (SVRR)		
14.5 Switch-on and switch-off		
14.6 PCB layout and grounding		
14.7 Typical performance characteristics		

26 W BTL and 2 × 13 W SE or 4 × 13 W SE power amplifier

TDA8512J

1 FEATURES

- Requires very few external components
- High output power
- Low output offset voltage Bridge-Tied Load (BTL) channel
- Fixed gain
- Good ripple rejection
- Mode select switch: operating, mute and standby
- Short-circuit safe to ground and across load
- Low power dissipation in any short-circuit condition
- Thermally protected
- Reverse polarity safe
- Electrostatic discharge protection
- No switch-on and switch-off plops

- Flexible leads
- Low thermal resistance
- Identical inputs: inverting and non-inverting.

2 APPLICATIONS

- Multimedia systems
- Active speaker systems (stereo with sub woofer or QUAD).

3 GENERAL DESCRIPTION

The TDA8512J is an integrated class-B output amplifier in a 17-lead Single-In-Line (SIL) power package. It contains 4 × 13 W Single Ended (SE) amplifiers of which two can be used to configure a 26 W BTL amplifier.

4 QUICK REFERENCE DATA

SYMBOL	PARAMETER	CONDITIONS	MIN.	TYP.	MAX.	UNIT
General						
V_P	supply voltage		6	15	18	V
I_{ORM}	repetitive peak output current		–	–	4	A
$I_{q(tot)}$	total quiescent current		–	80		mA
I_{stb}	standby current		–	0.1	100.0	μA
BTL channel						
P_o	output power	$R_L = 4 \Omega$; THD = 10%	–	26	–	W
SVRR	supply voltage ripple rejection		46	–	–	dB
$V_{n(o)}$	noise output voltage	$R_s = 0 \Omega$	–	70	–	μV
$ Z_i $	input impedance		25	–	–	kΩ
$ \Delta V_{OO} $	DC output offset voltage		–	–	150	mV
SE channels						
P_o	output power	THD = 10% $R_L = 4 \Omega$ $R_L = 2 \Omega$	– –	7.0 13.0	– –	W W
SVRR	supply voltage ripple rejection		46	–	–	dB
$V_{n(o)}$	noise output voltage	$R_s = 0 \Omega$	–	50	–	μV
$ Z_i $	input impedance		50	–	–	kΩ

5 ORDERING INFORMATION

TYPE NUMBER	PACKAGE		
	NAME	DESCRIPTION	VERSION
TDA8512J	DBS17P	plastic DIL-bent-SIL power package; 17 leads (lead length 12 mm)	SOT243-1

26 W BTL and 2 × 13 W SE or
4 × 13 W SE power amplifier

TDA8512J

6 BLOCK DIAGRAM

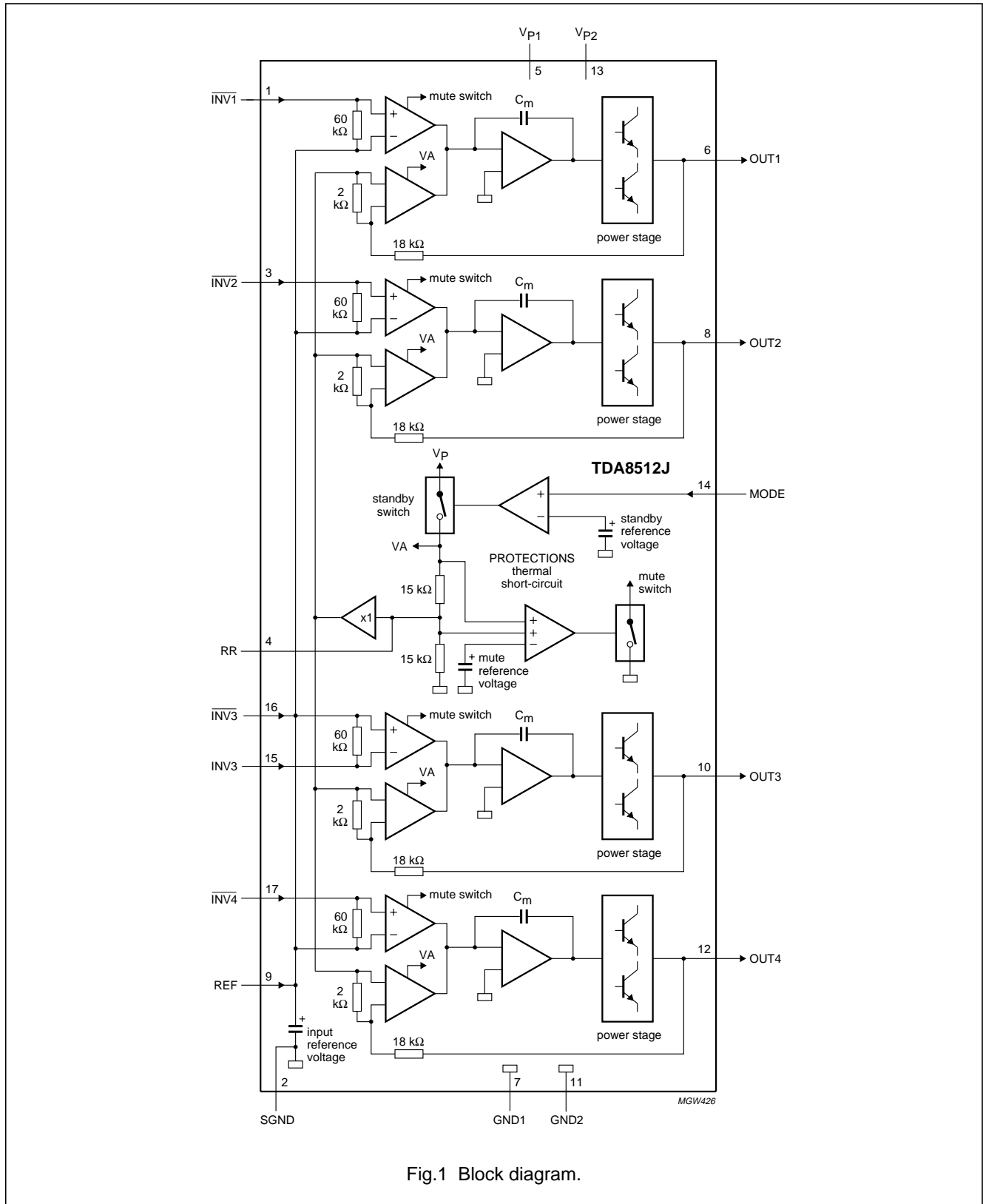

Fig.1 Block diagram.

26 W BTL and 2 × 13 W SE or
4 × 13 W SE power amplifier

TDA8512J

7 PINNING

SYMBOL	PIN	DESCRIPTION
INV1	1	non-inverting input 1
SGND	2	signal ground
INV2	3	non-inverting input 2
RR	4	supply voltage ripple rejection
V _{P1}	5	supply voltage 1
OUT1	6	output 1
GND1	7	power ground 1
OUT2	8	output 2
REF	9	reference voltage input
OUT3	10	output 3
GND2	11	power ground 2
OUT4	12	output 4
V _{P2}	13	supply voltage 2
MODE	14	mode select switch input
INV3	15	inverting input 3
INV3	16	non-inverting input 3
INV4	17	non-inverting input 4

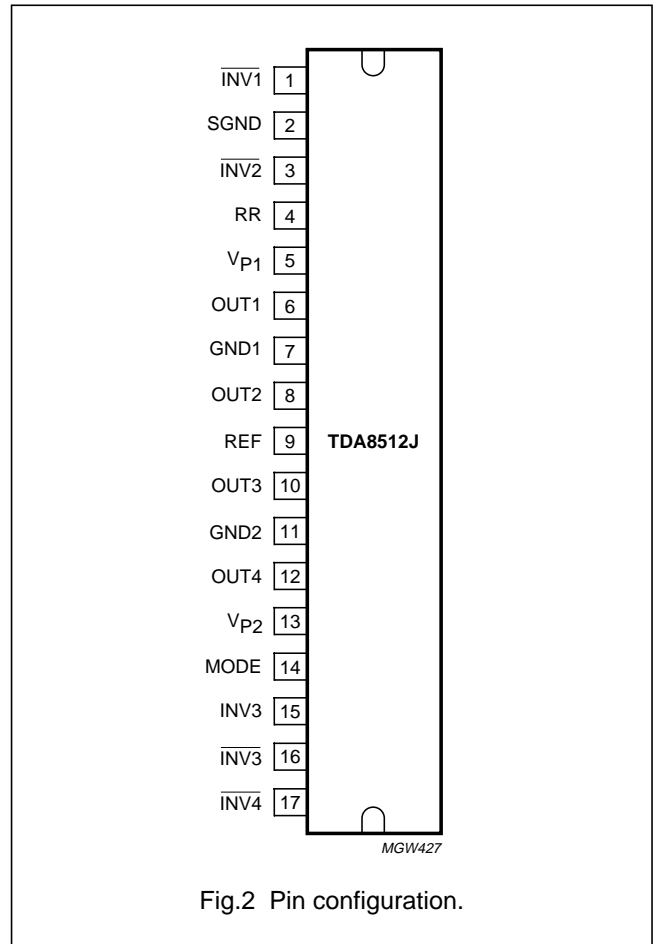

Fig.2 Pin configuration.

26 W BTL and 2×13 W SE or 4×13 W SE power amplifier

TDA8512J

8 FUNCTIONAL DESCRIPTION

The TDA8512J contains four identical amplifiers and can be used in the configurations:

- Two SE channels (fixed gain 20 dB) and one BTL channel (fixed gain 26 dB)
- Four SE channels.

(R_L depends on the application).

8.1 Mode select switch

A special feature of the TDA8512J device is the mode select switch (pin MODE), offering:

- Low standby current ($<100 \mu\text{A}$)
- Low switching current (low cost supply switch)
- Mute facility.

To avoid switch-on plops, it is advised to keep the amplifier in the mute mode for longer than 100 ms to allow charging of the input capacitors at pins $\overline{\text{INV1}}$, INV2 , INV3 , INV3 and $\overline{\text{INV4}}$. This can be achieved by:

- Control via a microcontroller
- An external timing circuit (see Fig.3).

The circuit slowly ramps up the voltage at the pin MODE when switching on, and results in fast muting when switching off.

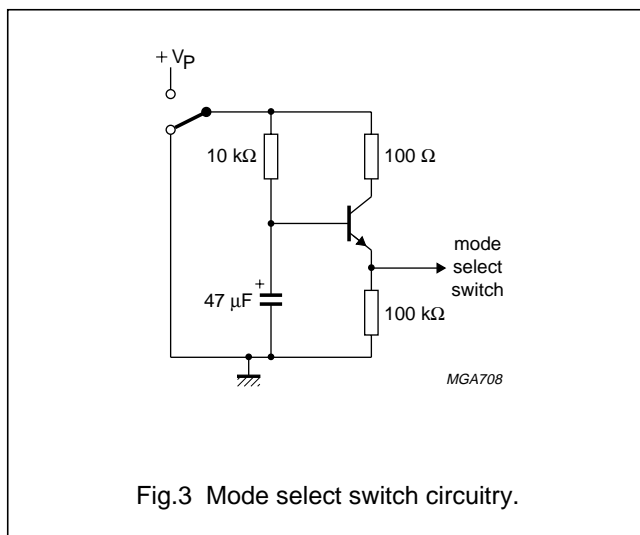

Fig.3 Mode select switch circuitry.

8.2 Mode select

For the 3 functional modes; standby, mute and operate, the pin MODE can be driven by a 3-state logic output stage: e.g. microcontroller with some extra components for DC level shifting. (see Fig.10).

Standby mode will be activated by applying a low DC level between 0 and 2 V. The power consumption of the device will be reduced to less than 1.5 mW. The input and output pins are floating: high impedance condition.

Mute mode will be activated by applying a DC level between 3.3 and 6.4 V. The outputs of the amplifier will be muted (no audio output); however, the amplifier is DC biased and the DC level of the input and output pins stays on half the supply voltage.

Operating mode is obtained at a DC level between 8.5 V and V_P .

8.3 Built-in protection circuits

The device contains both a thermal protection, and a short-circuit protection.

Thermal protection:

The junction temperature is measured by a temperature sensor; at a junction temperature of about 160 $^{\circ}\text{C}$ this detection circuit switches off the power stages.

Short-circuit protection (outputs to ground, supply and across the load):

Short-circuit is detected by a so called Maximum Current Detection circuit, which measures the current in the positive, respectively negative supply line of each power stage. At currents exceeding (typical) 6 A, the power stages are switched off during some ms.

8.4 Short-circuit protection

When a short-circuit during operation to either GND or across the load of one or more channels occurs, the output stages are switched off for approximately 20 ms. After that time, it is checked during approximately 50 μs to see whether the short-circuit is still present. Due to this duty factor of 50 μs per 20 ms, the average supply current is very low during this short-circuit (approximately 40 mA, see Fig.4).

26 W BTL and 2 × 13 W SE or
4 × 13 W SE power amplifier

TDA8512J

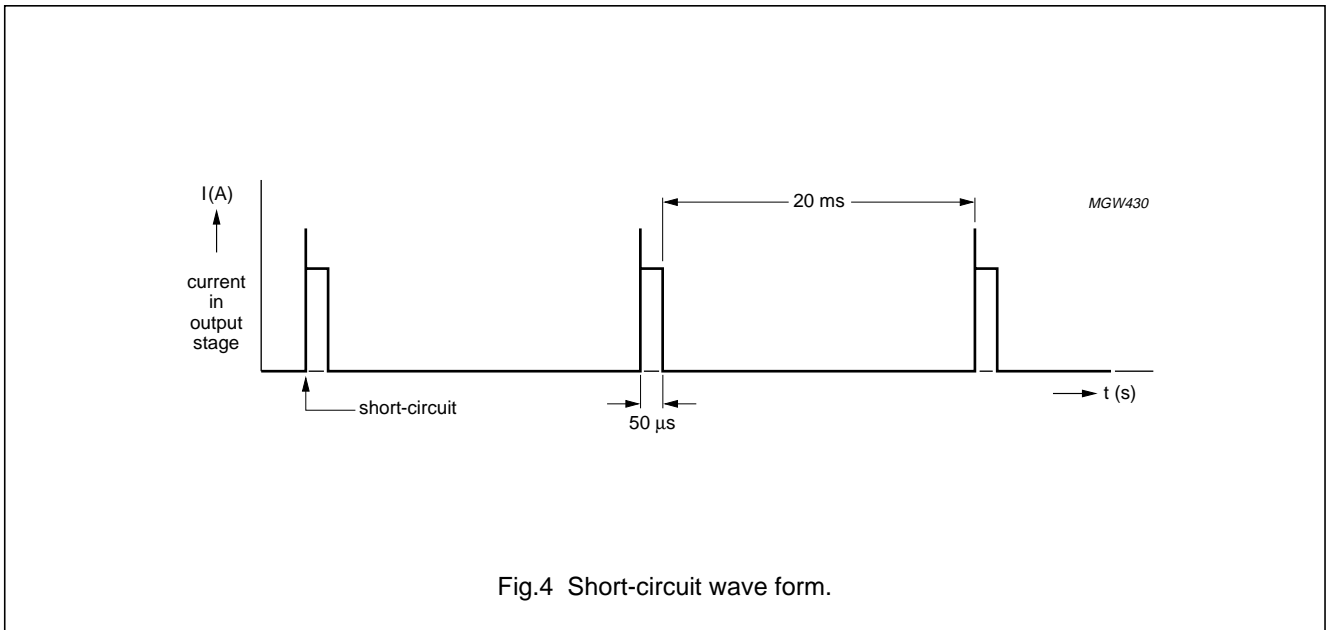

Fig.4 Short-circuit wave form.

9 LIMITING VALUES

In accordance with the Absolute Maximum Rating System (IEC 60134).

SYMBOL	PARAMETER	CONDITIONS	MIN.	MAX.	UNIT
V_P	supply voltage	operating	–	18	V
		no signal	–	21	V
I_{OSM}	non-repetitive peak output current		–	6	A
I_{ORM}	repetitive peak output current		–	4	A
V_{sc}	short-circuit safe voltage	operating; note 1	–	18	V
V_{rp}	reverse polarity voltage		–	6	V
P_{tot}	total power dissipation		–	60	W
T_{stg}	storage temperature		–55	+150	°C
T_{amb}	ambient temperature		–40	+85	°C
T_{vj}	virtual junction temperature		–	150	°C

Note

1. To ground and across load.

10 HANDLING

ESD protection of this device complies with the Philips' General Quality Specification (GQS).

26 W BTL and 2 × 13 W SE or
4 × 13 W SE power amplifier

TDA8512J

11 THERMAL CHARACTERISTICS

In accordance with IEC 60747-1.

SYMBOL	PARAMETER	CONDITIONS	VALUE	UNIT
$R_{th(j-a)}$	thermal resistance from junction to ambient	in free air	40.0	K/W
$R_{th(j-c)}$	thermal resistance from junction to case	see Fig.5	1.3	K/W

The measured thermal resistance of the IC-package ($R_{th(j-c)}$) is maximum 1.3 K/W if all four channels are driven. For a maximum ambient temperature of 60 °C and $V_P = 15 V$, the following calculation for the heatsink can be made:

For the application two SE outputs with 2 Ω load, the measured worst-case sine-wave dissipation is 2 × 7 W

For the application BTL output with 4 Ω load, the worst-case sine-wave dissipation is 12.5 W.

So the total power dissipation is $P_{d(tot)} = 2 \times 7 + 12.5 W = 26.5 W$.

At $T_{j(max)} = 150 \text{ °C}$ the temperature increase, caused by the power dissipation, is: $\Delta T = 150 \text{ °C} - 60 \text{ °C} = 90 \text{ °C}$.

So $P_{d(tot)} \times R_{th(tot)} = \Delta T = 90 K$. As a result: $R_{th(tot)} = \frac{90}{26.5} = 3.4 K/W$ which means:

$R_{th(hs)} = R_{th(tot)} - R_{th(j-c)} = 3.4 - 1.3 = 2.1 K/W$.

The above calculation is for application at worst-case (stereo) sine-wave output signals. In practice, music signals will be applied. In that case the maximum power dissipation will be about the half the sine-wave power dissipation, which allows the use of a smaller heatsink.

So $P_{d(tot)} \times R_{th(tot)} = \Delta T = 90 K$. As a result: $R_{th(tot)} = \frac{90}{13.25} = 6.8 K/W$ which means:

$R_{th(hs)} = R_{th(tot)} - R_{th(j-c)} = 6.8 - 1.3 = 5.5 K/W$.

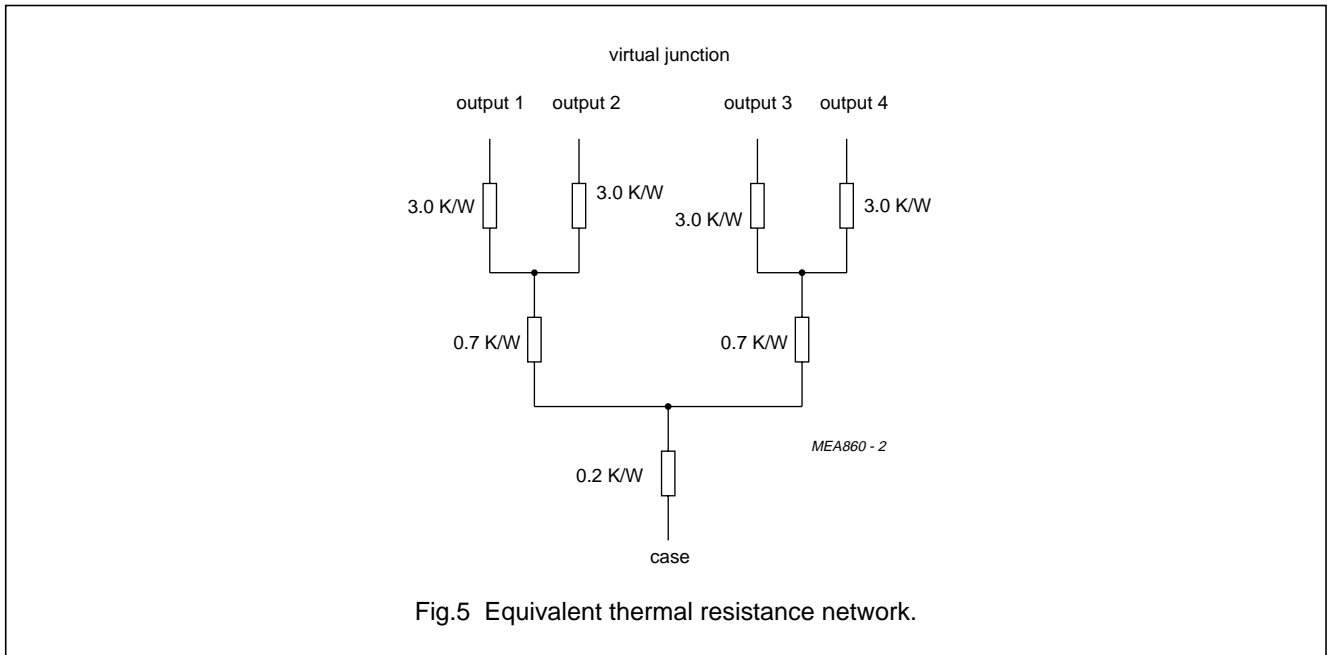

26 W BTL and 2 × 13 W SE or 4 × 13 W SE power amplifier

TDA8512J

12 DC CHARACTERISTICS

$V_P = 15\text{ V}$; $T_{\text{amb}} = 25\text{ °C}$; measured according to Figs 6 and 7; unless otherwise specified.

SYMBOL	PARAMETER	CONDITIONS	MIN.	TYP.	MAX.	UNIT
Supply						
V_P	supply voltage	note 1	6	15	18	V
$I_{q(\text{tot})}$	total quiescent current		–	80	160	mA
V_O	DC output voltage		–	6.9	–	V
$ \Delta V_{OO} $	DC output offset voltage	note 2	–	–	150	mV
Mode select switch						
$V_{\text{sw(on)}}$	switch-on voltage		8.5	–	–	V
Mute condition						
V	mute voltage		3.3	–	6.4	V
V_O	output voltage	$V_{i(\text{max})} = 1\text{ V}$; $f_i = 1\text{ kHz}$	–	–	2	mV
$ \Delta V_{OO} $	DC output offset voltage	note 2	–	–	150	mV
Standby condition						
V_{stb}	standby voltage		0	–	2	V
I_{stb}	standby current		–	–	100	μA
$I_{\text{sw(on)}}$	switch-on current		–	12	40	μA

Notes

- The circuit is DC adjusted at $V_P = 6$ to 18 V and AC operating at $V_P = 8.5$ to 18 V .
- Only for BTL channel ($V_{\text{OUT4}} - V_{\text{OUT3}}$).

13 AC CHARACTERISTICS

$V_P = 15\text{ V}$; $f_i = 1\text{ kHz}$; $T_{\text{amb}} = 25\text{ °C}$; bandpass 22 Hz to 22 kHz; measured according to Figs 6 and 7; unless otherwise specified.

SYMBOL	PARAMETER	CONDITIONS	MIN.	TYP.	MAX.	UNIT
BTL channel						
P_o	output power	$R_{L2} = 4\ \Omega$ (see Fig.7); note 1 THD = 0.5% THD = 10%	16 22	20 26	– –	W W
THD	total harmonic distortion	$P_o = 1\text{ W}$	–	0.06	–	%
B_P	power bandwidth	THD = 0.5%; $P_o = -1\text{ dB}$ with respect to 17 W	–	20 to 15000	–	Hz
$f_{ro(l)}$	low frequency roll-off	at -1 dB ; note 2	–	25	–	Hz
$f_{ro(h)}$	high frequency roll-off	at -1 dB	20	–	–	kHz
G_V	closed loop voltage gain		25	26	27	dB
SVRR	supply voltage ripple rejection	note 3; operating mute standby	48 46 80	– – –	– – –	dB dB dB

**26 W BTL and 2 × 13 W SE or
4 × 13 W SE power amplifier**

TDA8512J

SYMBOL	PARAMETER	CONDITIONS	MIN.	TYP.	MAX.	UNIT
$ Z_i $	input impedance		25	30	38	k Ω
$V_{n(o)}$	noise output voltage	operating; $R_s = 0 \Omega$; note 4	–	70	–	μV
		operating; $R_s = 10 \text{ k}\Omega$; note 4	–	100	200	μV
		mute; notes 4 and 5	–	60	–	μV
SE channels						
P_o	output power	$R_{L1} = 2 \Omega$ (see Fig.7); note 1 THD = 0.5% THD = 10%	8.0	10.0	–	W
			11.0	13.0	–	W
		$R_{L1} = 4 \Omega$ (see Fig.7); note 1 THD = 0.5% THD = 10%	–	5.5	–	W
			–	7.0	–	W
THD	total harmonic distortion	$P_o = 1 \text{ W}$	–	0.06	–	%
$f_{ro(l)}$	low frequency roll-off	at –1 dB; note 2	–	25	–	Hz
$f_{ro(h)}$	high frequency roll-off	at –1 dB	20	–	–	kHz
G_v	closed loop voltage gain		19	20	21	dB
SVRR	supply voltage ripple rejection	note 3; operating	48	–	–	dB
		mute	46	–	–	dB
		standby	80	–	–	dB
$ Z_i $	input impedance		50	60	75	k Ω
$V_{n(o)}$	noise output voltage	operating; $R_s = 0 \Omega$; note 4	–	50	–	μV
		operating; $R_s = 10 \text{ k}\Omega$; note 4	–	70	100	μV
		mute; notes 4 and 5	–	50	–	μV
α_{cs}	channel separation	$R_s = 10 \text{ k}\Omega$	40	60	–	dB
$ \Delta G_v $	channel unbalance		–	–	1	dB

Notes

- Output power is measured directly at the output pins of the device.
- Frequency response externally fixed.
- Ripple rejection measured at the output with a source impedance of 0 Ω ; maximum ripple of 2 V (p-p) and at a frequency between 100 Hz to 10 kHz.
- Noise measured in a bandwidth of 20 Hz to 20 kHz.
- Noise output voltage independant of R_s ($V_i = 0 \text{ V}$).

26 W BTL and 2 × 13 W SE or 4 × 13 W SE power amplifier

TDA8512J

14 APPLICATION INFORMATION

14.1 Input configuration

- Inputs 1 and 2 are used for SE application on pin OUT1, respectively pin OUT2
- Input 3 can be configured for both SE and BTL application
- Input 4 can be used for SE application of pin OUT4, or for BTL application together with input 3. See Figs 6 and 7.

Note that the DC level of all input pins is half the supply voltage V_P , so coupling capacitors for the input pins are necessary!

Cut-off frequency for the input is: $f_{i(cc)} = 12$ Hz. Therefore it is not necessary to use high capacitor values on the input; so the delay during switch-on, which is necessary for charging the input capacitors, can be minimised. This results in a good low frequency response and good switch-on behaviour.

14.2 Output power

The output power versus supply voltage has been measured on the output pins of one channel, and at THD = 10%. The maximum output power is limited by the maximum supply voltage of 18 V and the maximum available output current: 4 A repetitive peak current.

14.3 Power dissipation

The power dissipation graphs are given for one output channel in SE, respectively BTL application. So for total worst-case power dissipation the P_d of each channel must be added up.

14.4 Supply Voltage Ripple Rejection (SVRR)

The SVRR is measured with an electrolytic capacitor of 100 μ F on pin RR and at a bandwidth of 10 Hz to 80 kHz, whereas the lowest frequencies can be lower than 10 Hz.

Proper supply bypassing is critical for low noise performance and high power supply rejection. The respective capacitor locations should be as close to the device as possible, and grounded to the power ground. A proper power supply decoupling also prevents oscillations.

For suppressing higher frequency transients (spikes) on the supply line a capacitor with low ESR (typical 0.1 μ F) has to be placed as close as possible to the device. For suppressing lower frequency noise and ripple signals, a large electrolytic capacitor (e.g. 1000 μ F or more) must be placed close to the device.

The bypass capacitor on the pin RR reduces the noise and ripple on the mid rail voltage. For good THD and noise performance, a low ESR capacitor is recommended.

14.5 Switch-on and switch-off

To avoid audible plops during switching on and switching off the supply voltage, the pin MODE has to be set in standby condition (<2V) before the voltage is applied (switch-on) or removed (switch-off). Via the mute mode, the input- and SVRR-capacitors are smoothly charged.

The turn-on and turn-off time can be influenced by an RC-circuit on the pin MODE (see Fig.3). Rapidly switching on and off of the device or the pin MODE, may cause "click and pop" noise. This can be prevented by a proper timing on the pin MODE.

14.6 PCB layout and grounding

For high system performance level certain grounding techniques are imperative. The input reference grounds have to be tied with their respective source grounds, and must have separate traces from the power ground traces; this will separate the large (output) signal currents from interfering with the small AC input signals. The small-signal ground traces should be physically located as far as possible from the power ground traces. Supply- and output-traces should be as wide as practical for delivering maximum output power. The PCB layout, which accommodates the TDA8510, TDA8511, and TDA8512 products, is shown in Fig.8.

26 W BTL and 2 × 13 W SE or
4 × 13 W SE power amplifier

TDA8512J

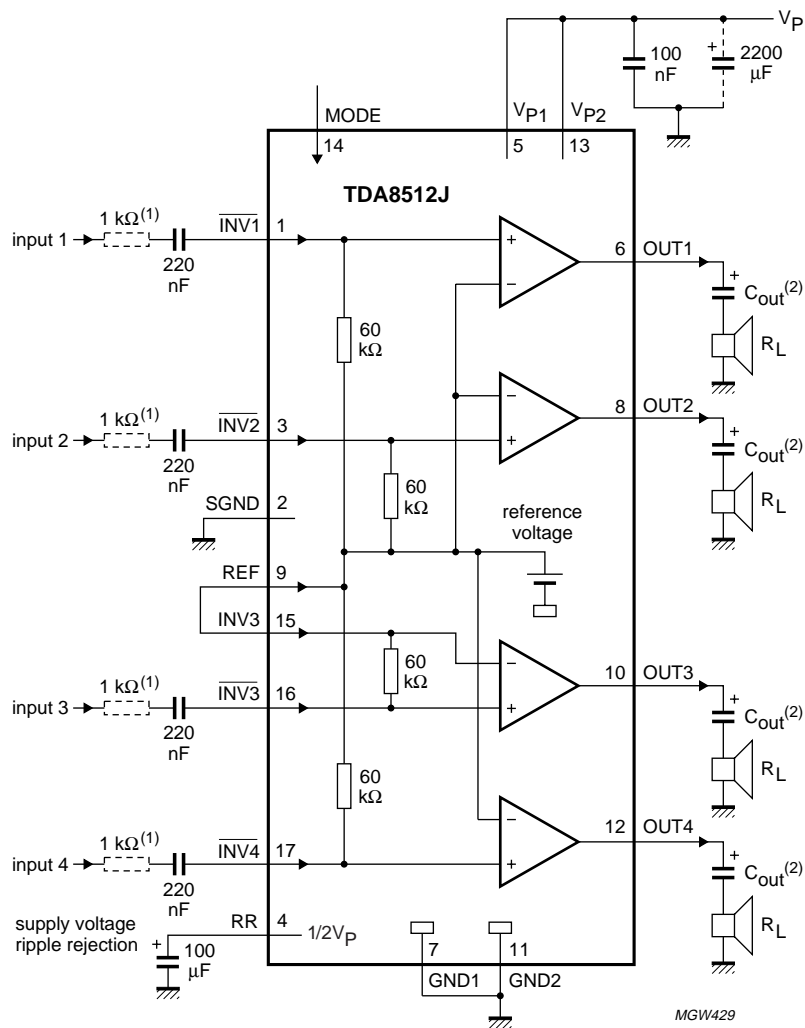

- (1) Advised when driven with hard clipping input signals.
- (2) For frequencies down to 20 Hz:
 $C_{out} = 4700 \mu F$ at $R_L = 2 \Omega$.
 $C_{out} = 2200 \mu F$ at $R_L = 4 \Omega$.

Fig.6 Application diagram for four SE amplifiers.

26 W BTL and 2 × 13 W SE or
4 × 13 W SE power amplifier

TDA8512J

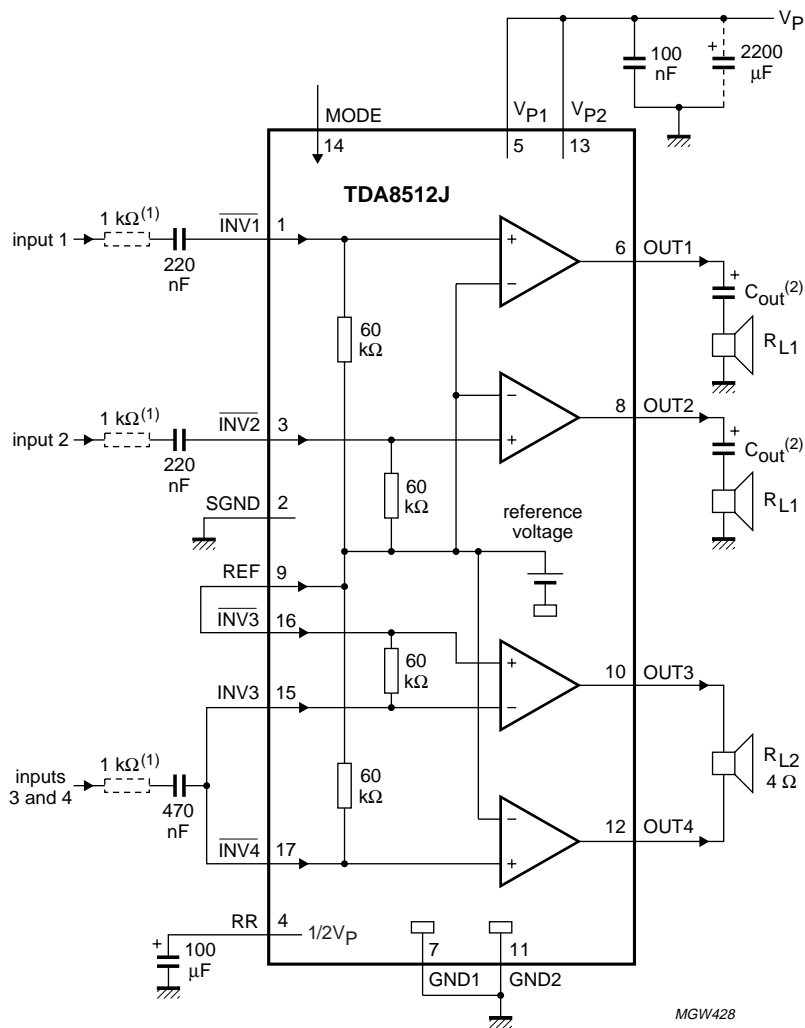

- (1) Advised when driven with hard clipping input signals.
- (2) For frequencies down to 20 Hz:
 $C_{out} = 4700 \mu\text{F}$ at $R_{L1} = 2 \Omega$.
 $C_{out} = 2200 \mu\text{F}$ at $R_{L1} = 4 \Omega$.

Fig.7 Application diagram for one BTL amplifier and two SE amplifiers.

26 W BTL and 2 × 13 W SE or
4 × 13 W SE power amplifier

TDA8512J

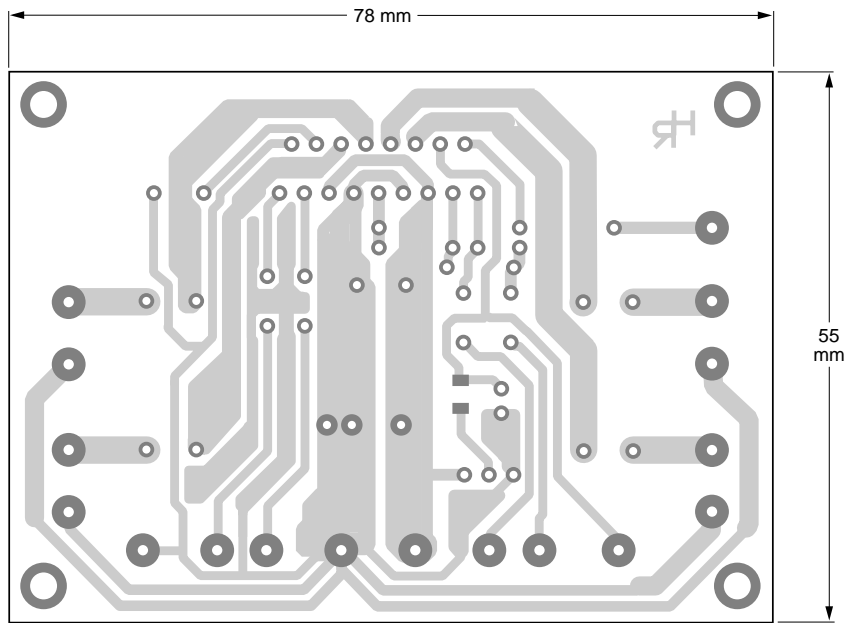

a. Top view copper layout.

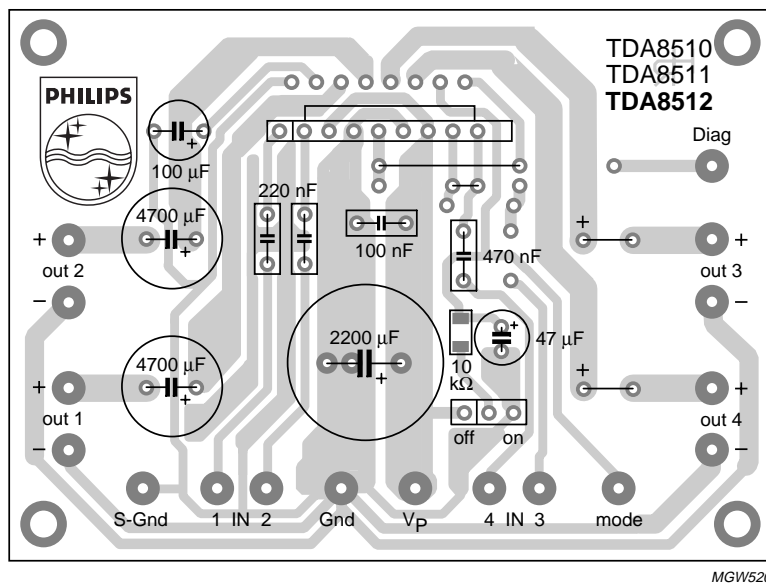

b. Top view component layout.

Fig.8 Printed-circuit board layout.

26 W BTL and 2 × 13 W SE or
4 × 13 W SE power amplifier

TDA8512J

14.7 Typical performance characteristics

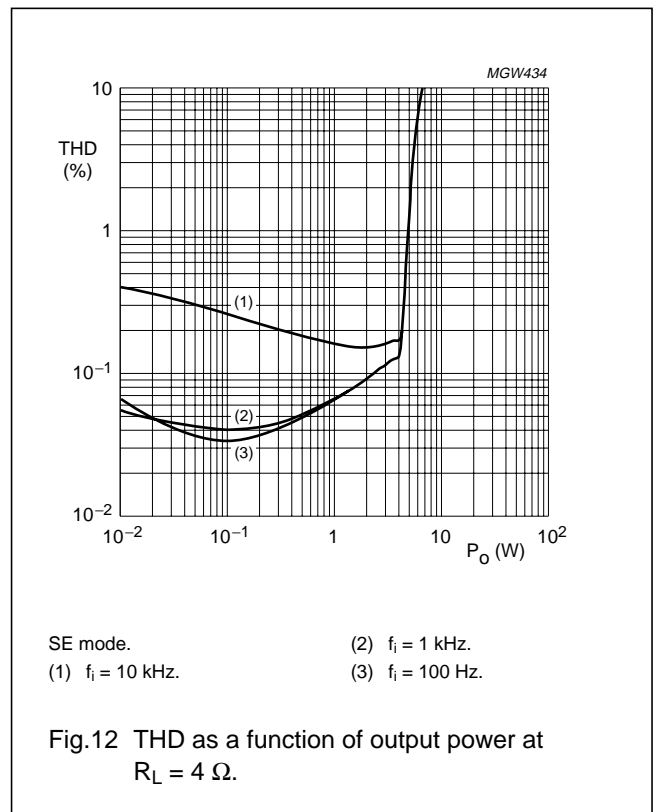
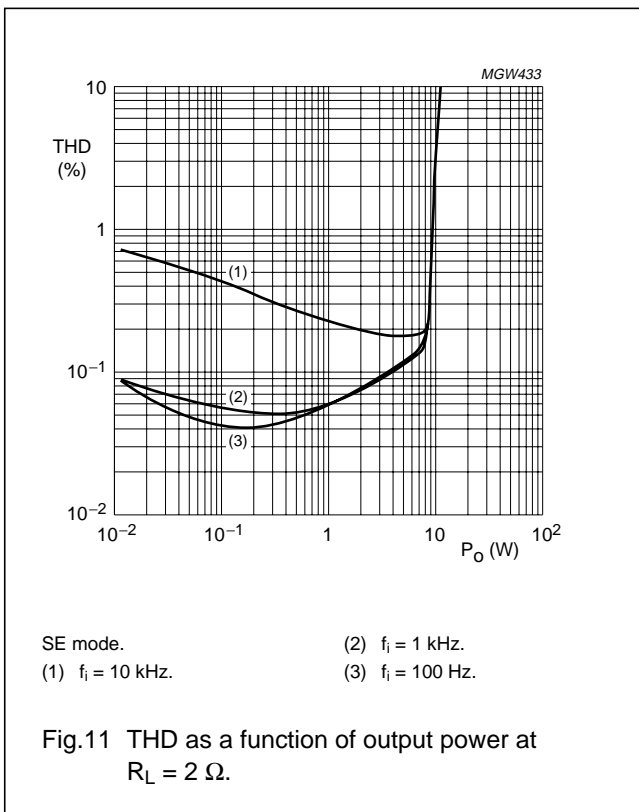
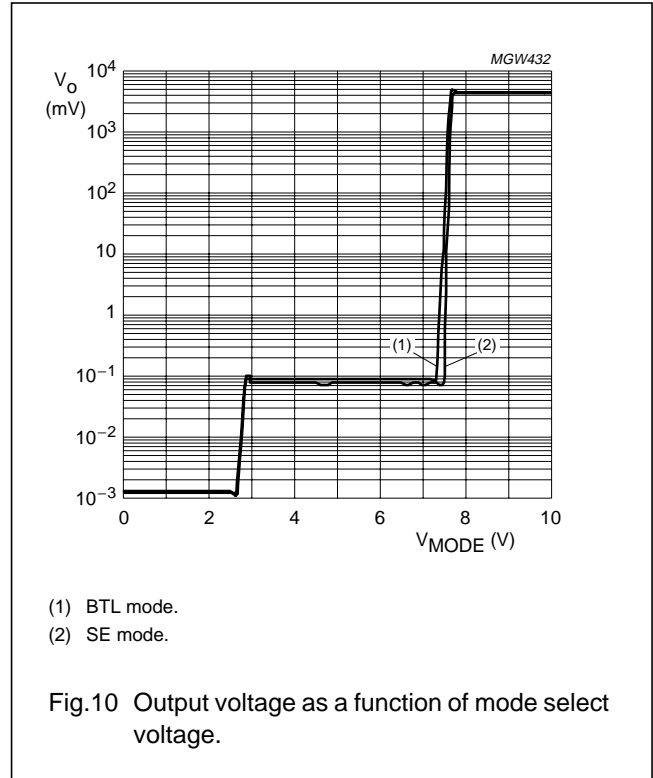
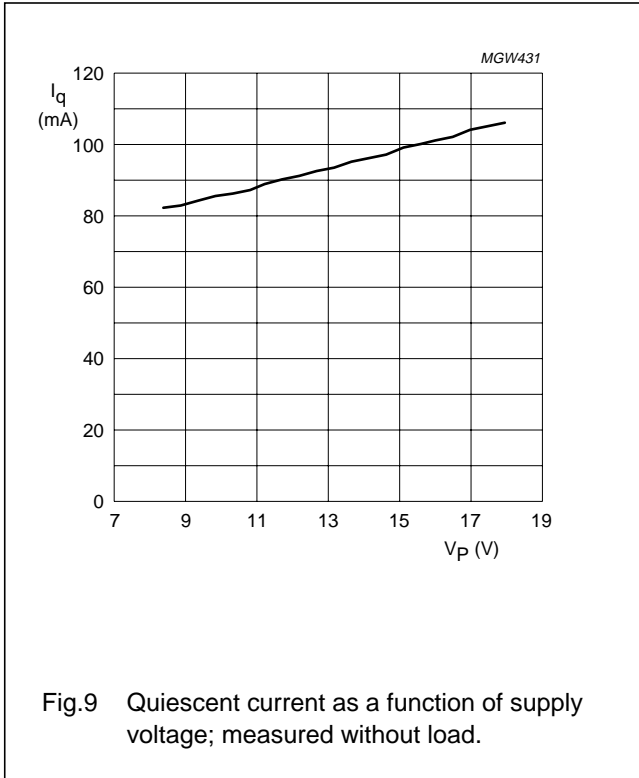

26 W BTL and 2 × 13 W SE or
4 × 13 W SE power amplifier

TDA8512J

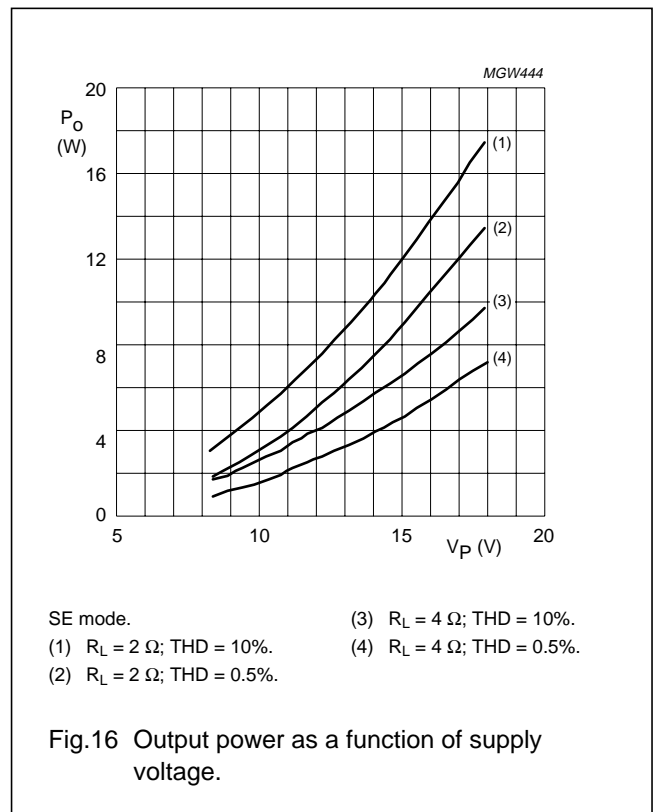
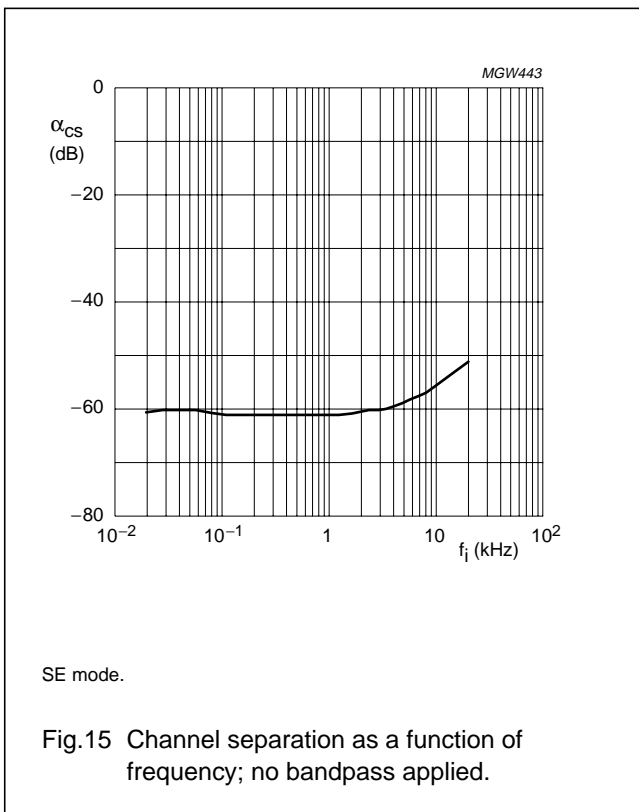
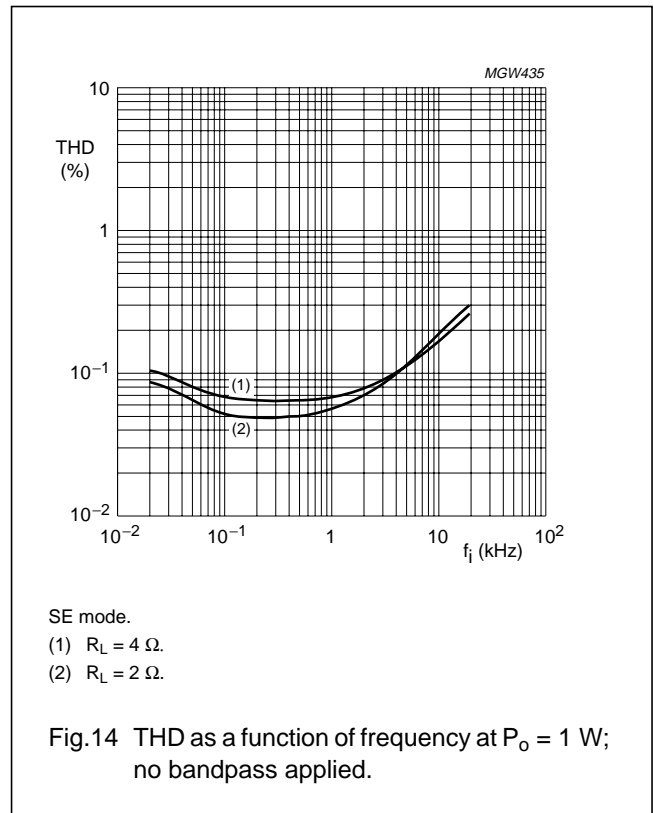
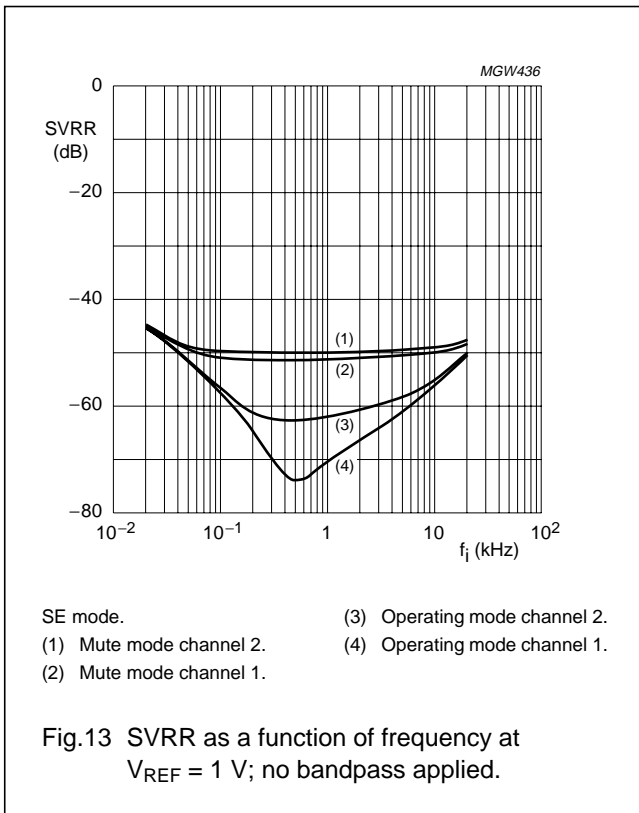

26 W BTL and 2 × 13 W SE or
4 × 13 W SE power amplifier

TDA8512J

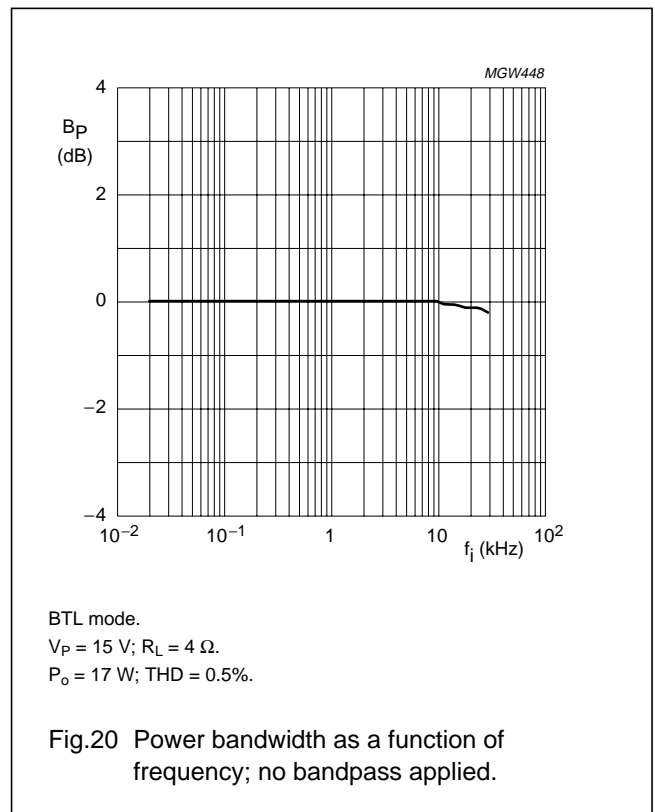
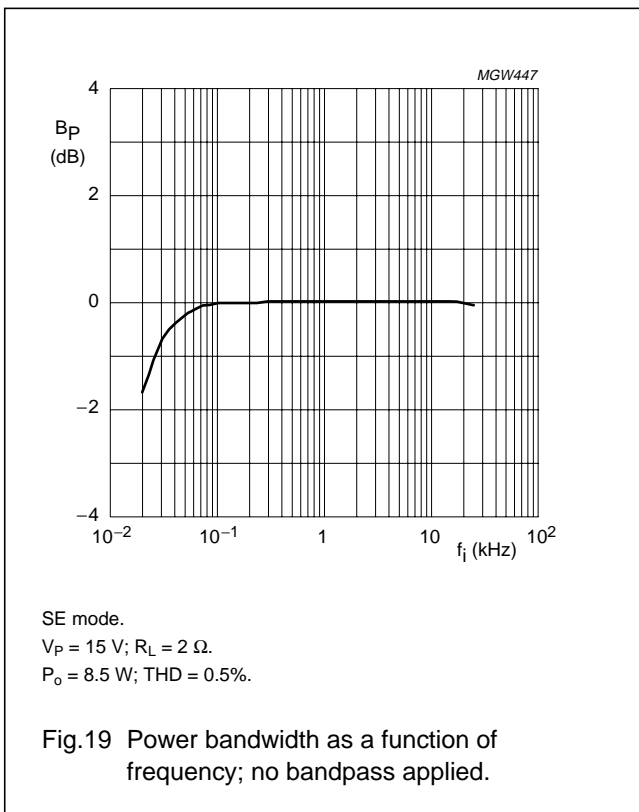
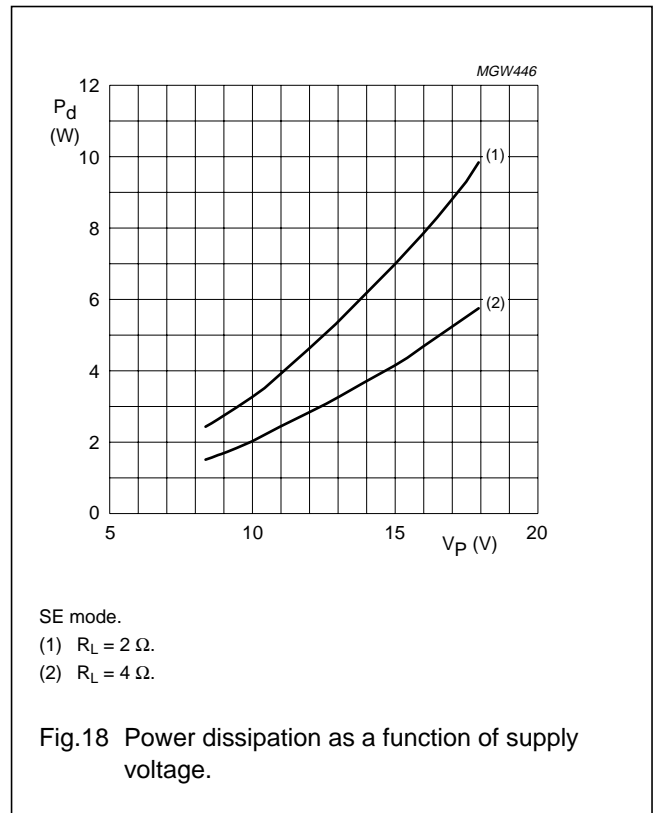
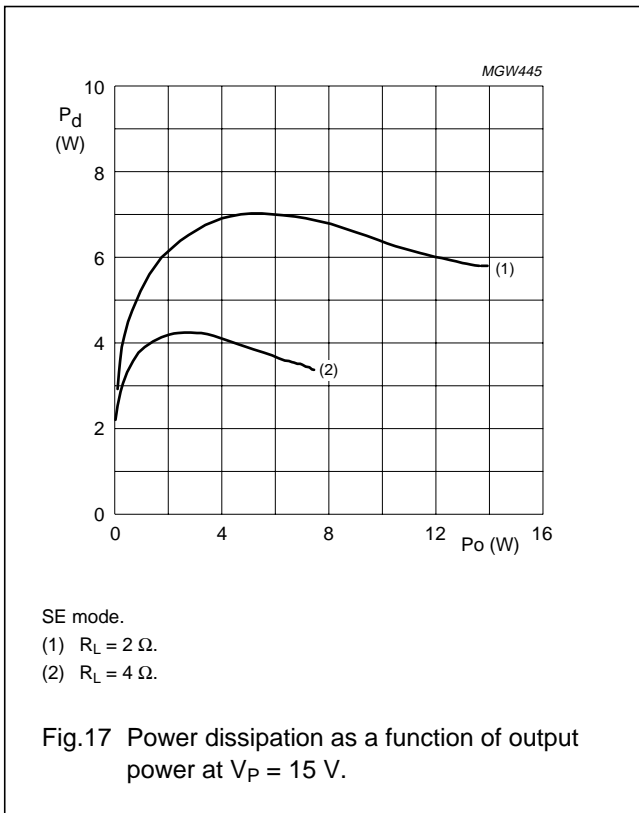

26 W BTL and 2 × 13 W SE or
4 × 13 W SE power amplifier

TDA8512J

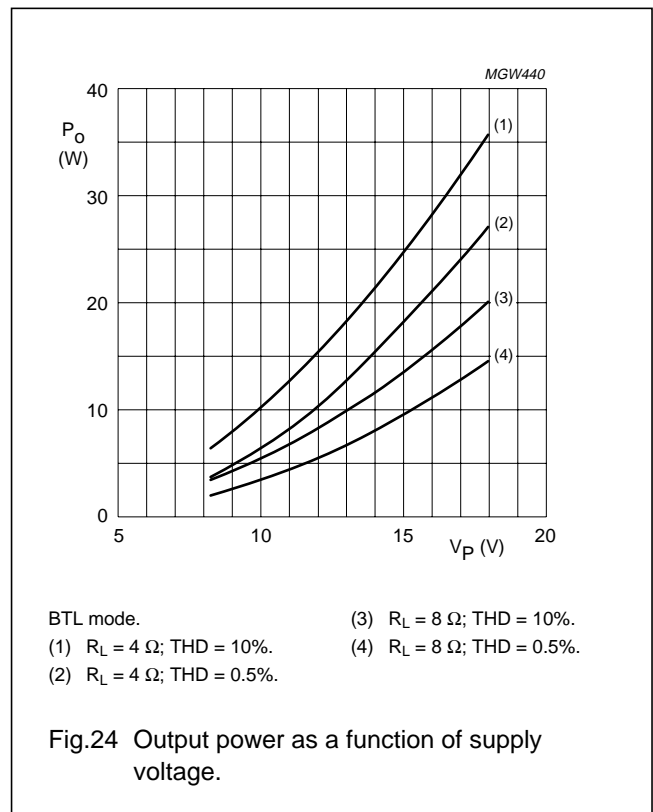
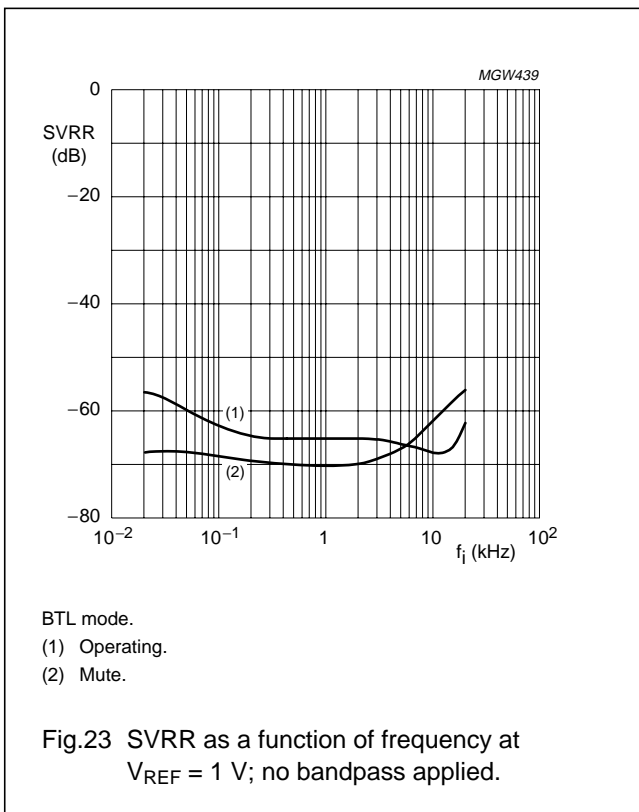
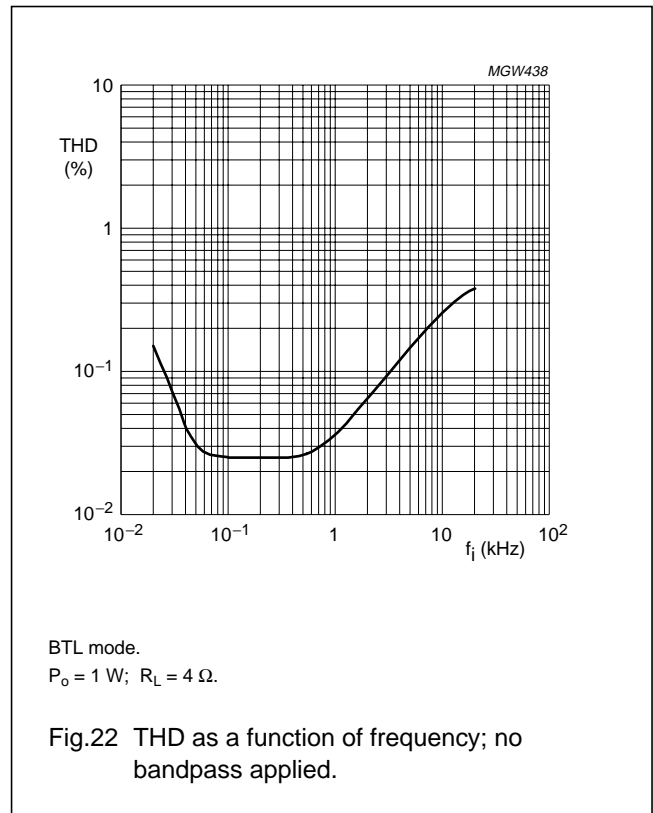
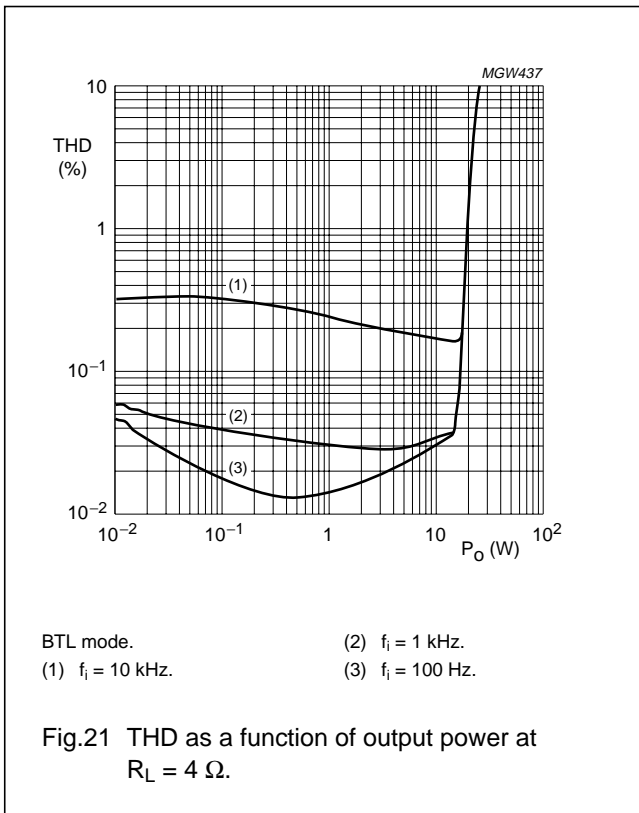

26 W BTL and 2 × 13 W SE or
4 × 13 W SE power amplifier

TDA8512J

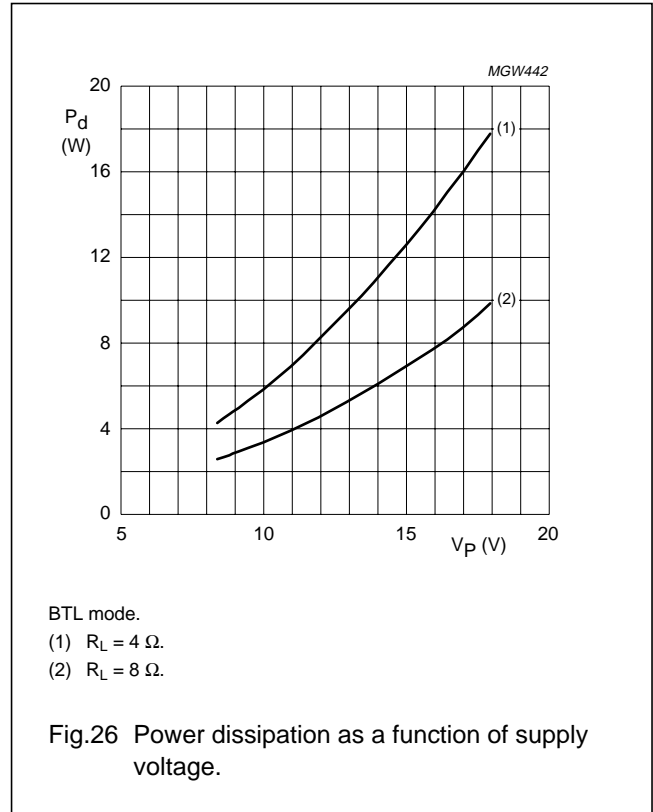
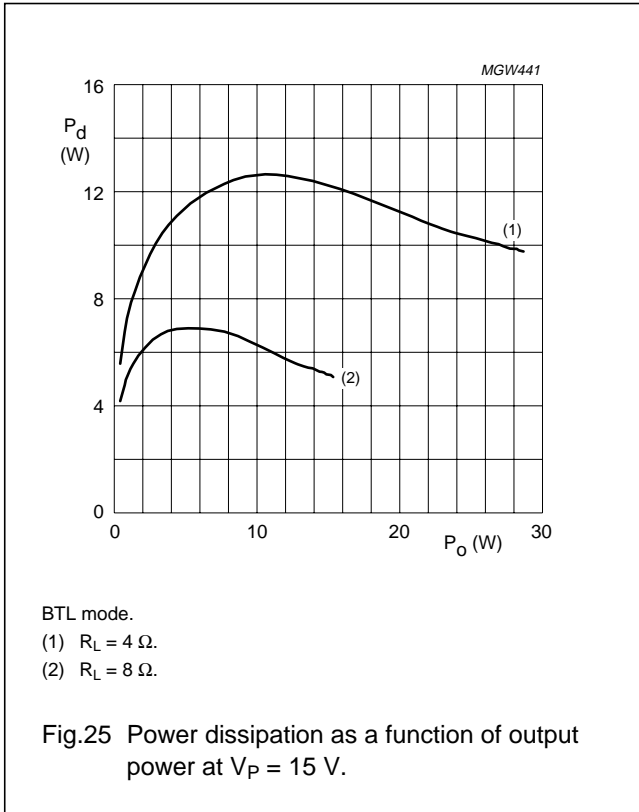

26 W BTL and 2 × 13 W SE or
4 × 13 W SE power amplifier

TDA8512J

15 PACKAGE OUTLINE

DBS17P: plastic DIL-bent-SIL power package; 17 leads (lead length 12 mm)

SOT243-1

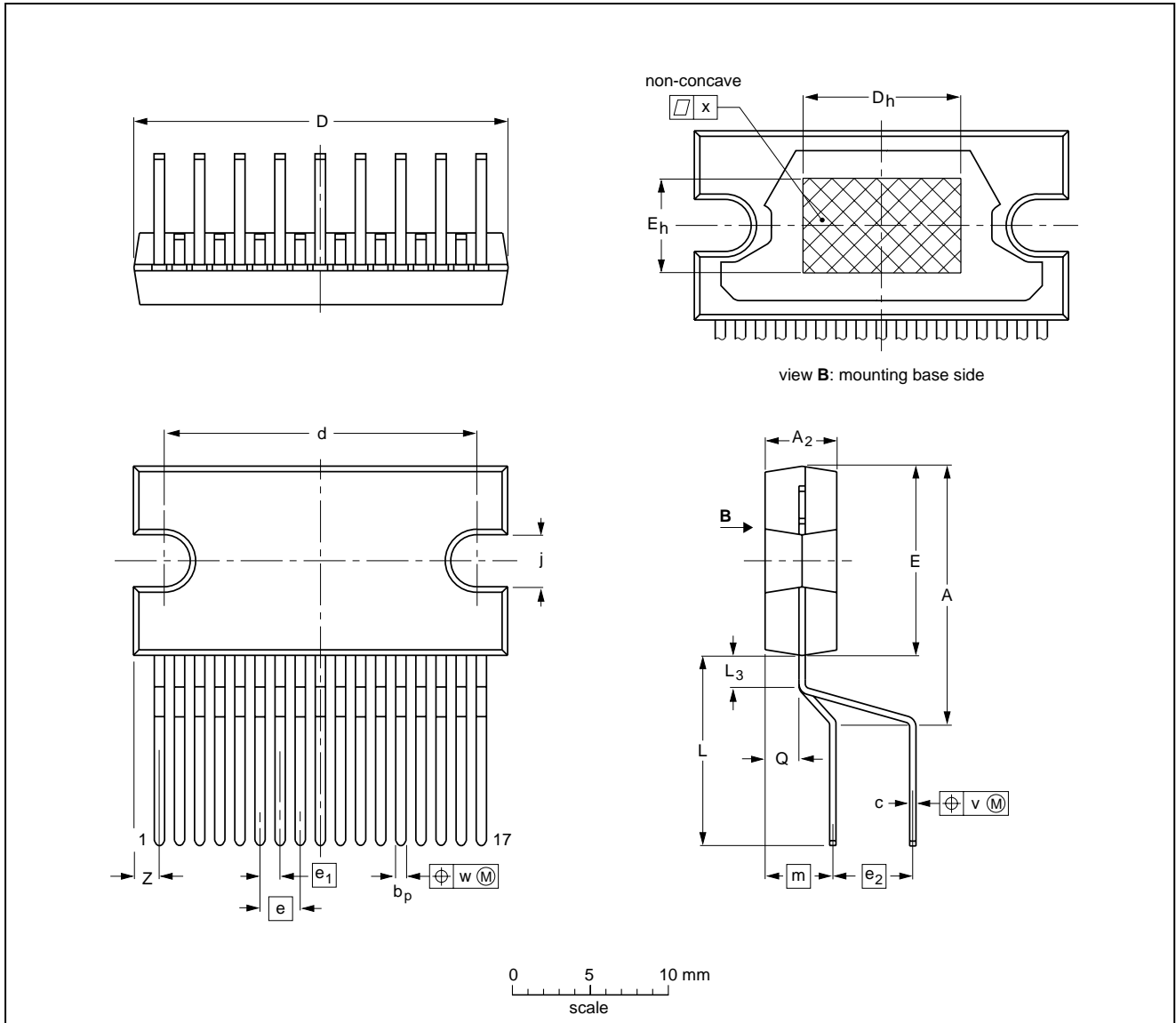

DIMENSIONS (mm are the original dimensions)

UNIT	A	A ₂	b _p	c	D ⁽¹⁾	d	D _h	E ⁽¹⁾	e	e ₁	e ₂	E _h	j	L	L ₃	m	Q	v	w	x	z ⁽¹⁾
mm	17.0 15.5	4.6 4.4	0.75 0.60	0.48 0.38	24.0 23.6	20.0 19.6	10	12.2 11.8	2.54	1.27	5.08	6	3.4 3.1	12.4 11.0	2.4 1.6	4.3	2.1 1.8	0.8	0.4	0.03	2.00 1.45

Note

1. Plastic or metal protrusions of 0.25 mm maximum per side are not included.

OUTLINE VERSION	REFERENCES				EUROPEAN PROJECTION	ISSUE DATE
	IEC	JEDEC	EIAJ			
SOT243-1						97-12-16 99-12-17

26 W BTL and 2 × 13 W SE or 4 × 13 W SE power amplifier

TDA8512J

16 SOLDERING

16.1 Introduction to soldering through-hole mount packages

This text gives a brief insight to wave, dip and manual soldering. A more in-depth account of soldering ICs can be found in our *"Data Handbook IC26; Integrated Circuit Packages"* (document order number 9398 652 90011).

Wave soldering is the preferred method for mounting of through-hole mount IC packages on a printed-circuit board.

16.2 Soldering by dipping or by solder wave

The maximum permissible temperature of the solder is 260 °C; solder at this temperature must not be in contact with the joints for more than 5 seconds.

16.4 Suitability of through-hole mount IC packages for dipping and wave soldering methods

PACKAGE	SOLDERING METHOD	
	DIPPING	WAVE
DBS, DIP, HDIP, SDIP, SIL	suitable	suitable ⁽¹⁾

Note

- For SDIP packages, the longitudinal axis must be parallel to the transport direction of the printed-circuit board.

The total contact time of successive solder waves must not exceed 5 seconds.

The device may be mounted up to the seating plane, but the temperature of the plastic body must not exceed the specified maximum storage temperature ($T_{stg(max)}$). If the printed-circuit board has been pre-heated, forced cooling may be necessary immediately after soldering to keep the temperature within the permissible limit.

16.3 Manual soldering

Apply the soldering iron (24 V or less) to the lead(s) of the package, either below the seating plane or not more than 2 mm above it. If the temperature of the soldering iron bit is less than 300 °C it may remain in contact for up to 10 seconds. If the bit temperature is between 300 and 400 °C, contact may be up to 5 seconds.

26 W BTL and 2 × 13 W SE or 4 × 13 W SE power amplifier

TDA8512J

17 DATA SHEET STATUS

DATA SHEET STATUS ⁽¹⁾	PRODUCT STATUS ⁽²⁾	DEFINITIONS
Objective data	Development	This data sheet contains data from the objective specification for product development. Philips Semiconductors reserves the right to change the specification in any manner without notice.
Preliminary data	Qualification	This data sheet contains data from the preliminary specification. Supplementary data will be published at a later date. Philips Semiconductors reserves the right to change the specification without notice, in order to improve the design and supply the best possible product.
Product data	Production	This data sheet contains data from the product specification. Philips Semiconductors reserves the right to make changes at any time in order to improve the design, manufacturing and supply. Changes will be communicated according to the Customer Product/Process Change Notification (CPCN) procedure SNW-SQ-650A.

Notes

1. Please consult the most recently issued data sheet before initiating or completing a design.
2. The product status of the device(s) described in this data sheet may have changed since this data sheet was published. The latest information is available on the Internet at URL <http://www.semiconductors.philips.com>.

18 DEFINITIONS

Short-form specification — The data in a short-form specification is extracted from a full data sheet with the same type number and title. For detailed information see the relevant data sheet or data handbook.

Limiting values definition — Limiting values given are in accordance with the Absolute Maximum Rating System (IEC 60134). Stress above one or more of the limiting values may cause permanent damage to the device. These are stress ratings only and operation of the device at these or at any other conditions above those given in the Characteristics sections of the specification is not implied. Exposure to limiting values for extended periods may affect device reliability.

Application information — Applications that are described herein for any of these products are for illustrative purposes only. Philips Semiconductors make no representation or warranty that such applications will be suitable for the specified use without further testing or modification.

19 DISCLAIMERS

Life support applications — These products are not designed for use in life support appliances, devices, or systems where malfunction of these products can reasonably be expected to result in personal injury. Philips Semiconductors customers using or selling these products for use in such applications do so at their own risk and agree to fully indemnify Philips Semiconductors for any damages resulting from such application.

Right to make changes — Philips Semiconductors reserves the right to make changes, without notice, in the products, including circuits, standard cells, and/or software, described or contained herein in order to improve design and/or performance. Philips Semiconductors assumes no responsibility or liability for the use of any of these products, conveys no licence or title under any patent, copyright, or mask work right to these products, and makes no representations or warranties that these products are free from patent, copyright, or mask work right infringement, unless otherwise specified.

26 W BTL and 2 × 13 W SE or
4 × 13 W SE power amplifier

TDA8512J

NOTES

Philips Semiconductors – a worldwide company

Contact information

For additional information please visit <http://www.semiconductors.philips.com>. Fax: +31 40 27 24825

For sales offices addresses send e-mail to: sales.addresses@www.semiconductors.philips.com.

© Koninklijke Philips Electronics N.V. 2001

SCA73

All rights are reserved. Reproduction in whole or in part is prohibited without the prior written consent of the copyright owner.

The information presented in this document does not form part of any quotation or contract, is believed to be accurate and reliable and may be changed without notice. No liability will be accepted by the publisher for any consequence of its use. Publication thereof does not convey nor imply any license under patent- or other industrial or intellectual property rights.

Printed in The Netherlands

753503/01/pp24

Date of release: 2001 Nov 16

Document order number: 9397 750 08677

Let's make things better.

**Philips
Semiconductors**



PHILIPS

This datasheet has been download from:

www.datasheetcatalog.com

Datasheets for electronics components.