

RF Amplifier for CD Player

For the availability of this product, please contact the sales office.

Description

The CXA1571M/N is developed for CD player usage. This IC integrates an APC circuit and RF, focus error and tracking error amplifiers for the 3-spot optical pick up output.

Features

- Low power consumption (at ± 5V, 60mW)
- Built-in APC circuit
- Both single +5V and dual ± 5V power supply operations possible
- APC circuit and various amplifiers gain interchangeable with CXA1081

Applications

Compact disc players

Operating Condition

Supply voltage	V _{CC} -V _{EE}	3.6 to 11.0	V
----------------	----------------------------------	-------------	---

Absolute Maximum Ratings (T_a=25 °C)

• Supply voltage	V _{CC} -V _{EE}	12	V
• Operating temperature	T _{opr}	-20 to +75	°C
• Storage temperature	T _{stg}	-65 to +150	°C
• Allowable power dissipation			
	P _D (SOP)	600	mW
	(SSOP)	375	mW

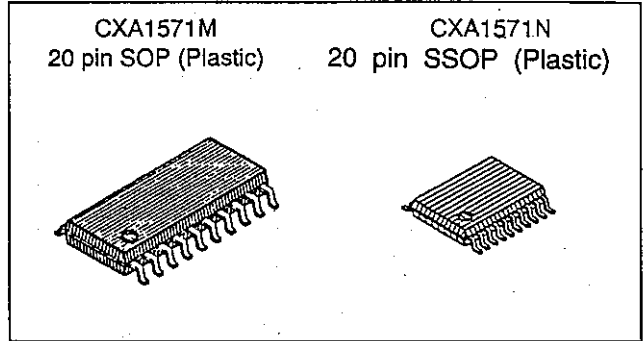

Functions

- RF amplifier
- Focus error amplifier
- Tracking error amplifier
- APC circuit

Structure

Bipolar silicon monolithic IC

Block Diagram and Pin Configuration (Top View)

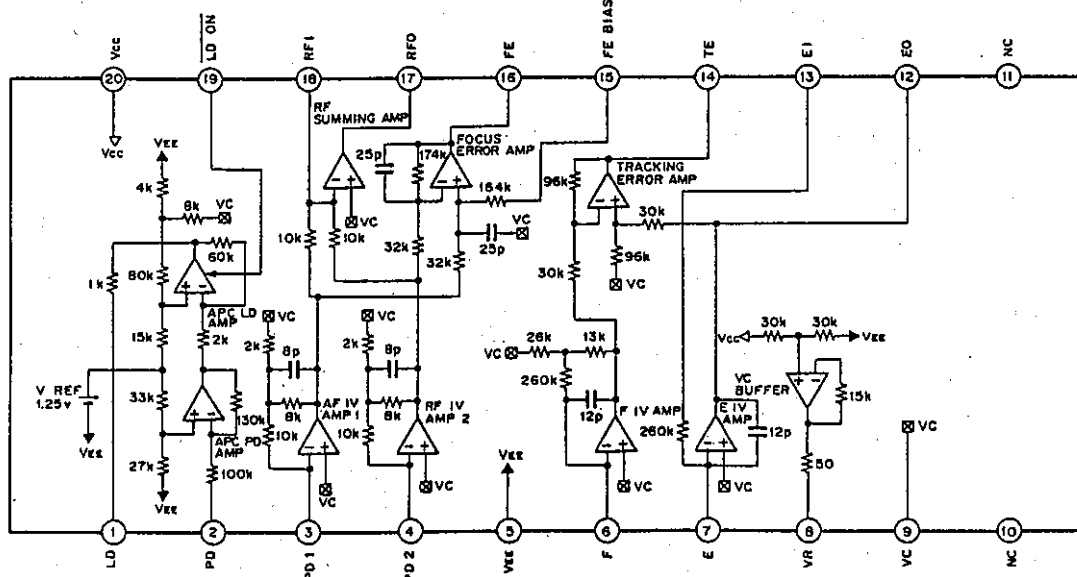

Sony reserves the right to change products and specifications without prior notice. This information does not convey any license by any implication or otherwise under any patents or other right. Application circuits shown, if any, are typical examples illustrating the operation of the devices. Sony cannot assume responsibility for any problems arising out of the use of these circuits.

Pin Description

Pin No.	Symbol	I/O	Equivalent circuit	Description
1	LD	O		Output pin of APC amplifier.
2	PD	I		Input pin of APC amplifier.
3 4	PD1 PD2	I I		Inversion input pins of RF I-V amplifier. Connect respectively to A+C and B+D photo diode pins. Current generated in the photo diode is converted to voltage inside the IC.
6 7	F-IN E-IN	I I		Inversion input pins of F, E I-V amplifier. Connect respectively to photo diode F, E. Current generated in the photo diode is converted to voltage inside the IC.

Pin No.	Symbol	I/O	Equivalent circuit	Description
8	VR	O		($V_{CC}+V_{EE}$)/2 DC voltage output pin.
9	VC	i		VC midpoint voltage input pin. Connect to GND when dual $\pm 5V$ power supply is used. Connect to VR pin when single +5V power supply is used.
12	EC	O		Output pin for I-V amplifier E monitor.
13	EI	—		Gain adjustment pin for I-V amplifier E.

Pin No.	Symbol	I/O	Equivalent circuit	Description
14	TE	O		Output pin of the tracking error amplifier. E-F signal is output
15	FE-BIAS	I		Bias adjustment pin on the non inverted side of the focus error amplifier.
16	FE	O		Output pin of the focus error amplifier.
17	RFO	O		Output pin of the RF amplifier.

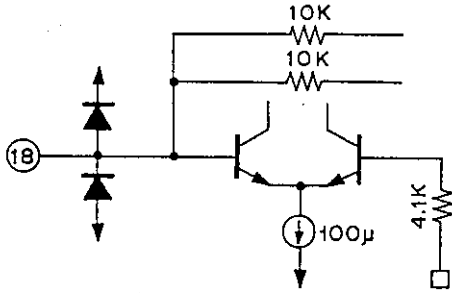
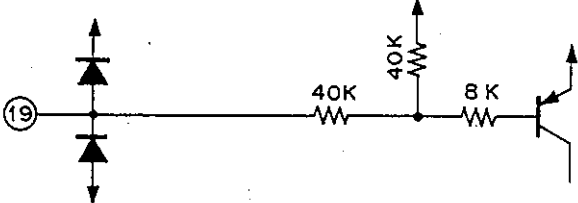
Pin No.	Symbol	I/O	Equivalent circuit	Description
18	RFI	I		<p>Input pin on the inverted side of RF amplifier. RF amplifier gain is determined by the resistance connected between this pin and RFO pin.</p>
19	$\overline{\text{LD-ON}}$	I		<p>ON/OFF selection pin of APC amplifier. ON at GND and OFF at Vcc.</p>

Electrical Characteristics

± 5V power supply (V_{CC}=5.0V, V_{EE}=-5.0V, V_C=GND)

Test No.	Test item	Symbol	SW conditions							Bias conditions			Test point	Output waveform and test method	Limit					
			1	2	3	4	5	6	7	E1	E2	E3			Min.	Typ.	Max.	Unit		
1	Current consumption	I _{CC}								300mV			20	V _{CC} =5V, V _{EE} =-5V V _C =0V	—	8	12	mV		
2		I _{EE}											5		-12	-8	—			
3	RF amplifier	Offset voltage 1								0V			17	Same here after	-50	—	50	mV		
5		Voltage gain		○	○										25.1	28.1	31.1		dB	
6		Max. output amplitude H		○							0.6V					3.5	—			—
7	Max. output amplitude L			○						-0.6V				—	—	-0.3				
9	FE amplifier	Offset voltage											16	V _I =1kHz, 32mVp-p	-120	0	+120	mV		
10		Voltage gain 1		○											27.0	30.0	33.0		dB	
11		Voltage gain 2			○										27.0	30.0	33.0			
13		Voltage gain difference														-3	0			3
16		Max. output amplitude H		○							0.3V					4.2	—			—
17	Max. output amplitude L			○						0.3V				—	—	-2.2				
18	TE amplifier	Offset voltage 1											14	V _I =1kHz, 300mVp-p	-50	0	50	mV		
20		Voltage gain 1				○	○								7.0	10.0	13.0		dB	
21		Voltage gain 2					○	○							7.0	10.0	13.0			
23		Voltage gain difference														-3	0			3
26		Max. output amplitude H					○				2.5V					4.2	—			—
27	Max. output amplitude L					○				2.5V				—	—	-2.2				
30	APC	Output voltage 1						○	69mV		0.5V	1	I _I =0.8mA	—	-1.7	-0.4	V			
31		Output voltage 2						○	123mV					-1.0	0.3	1.6				
32		Output voltage 3						○	177mV					1.0	2.3	—				
33		Output voltage 4						○	0V		4.5V			4.6	4.8	—				
33		Output voltage 5		○					○	0V		0.5V			—	—		2.0		
34	Micropoint amplifier	Output voltage 1										8		-100	0	100	mV			

Electrical Characteristics Test Circuit

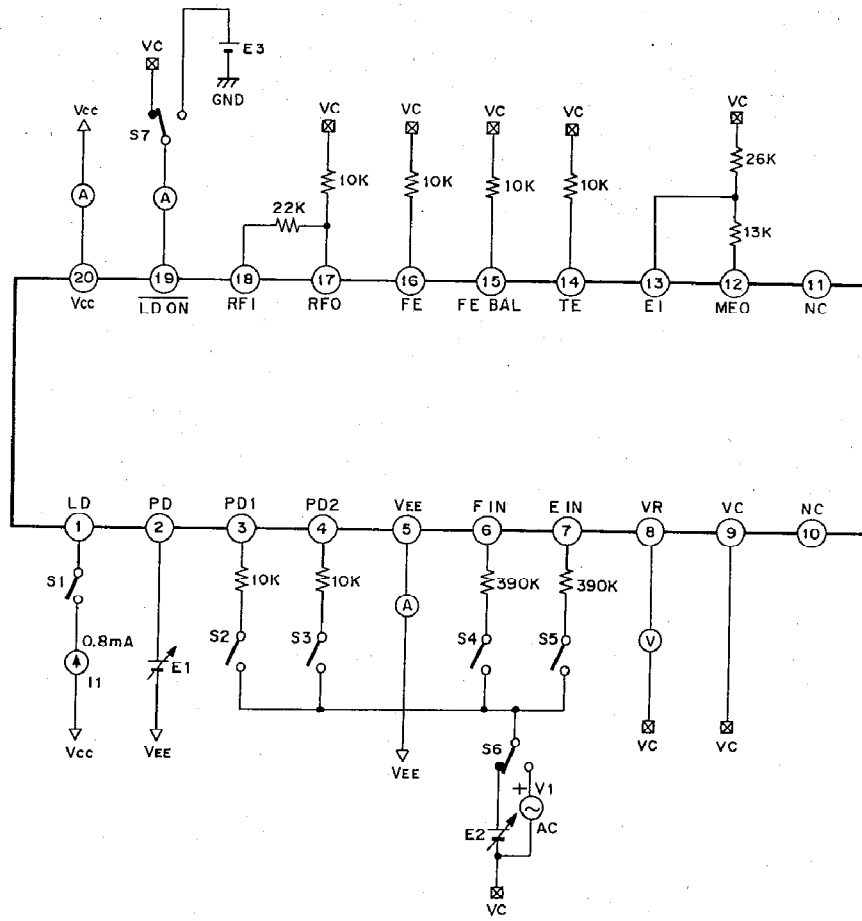

- 7 -

Application Circuit

- For dual $\pm 5V$ power supply

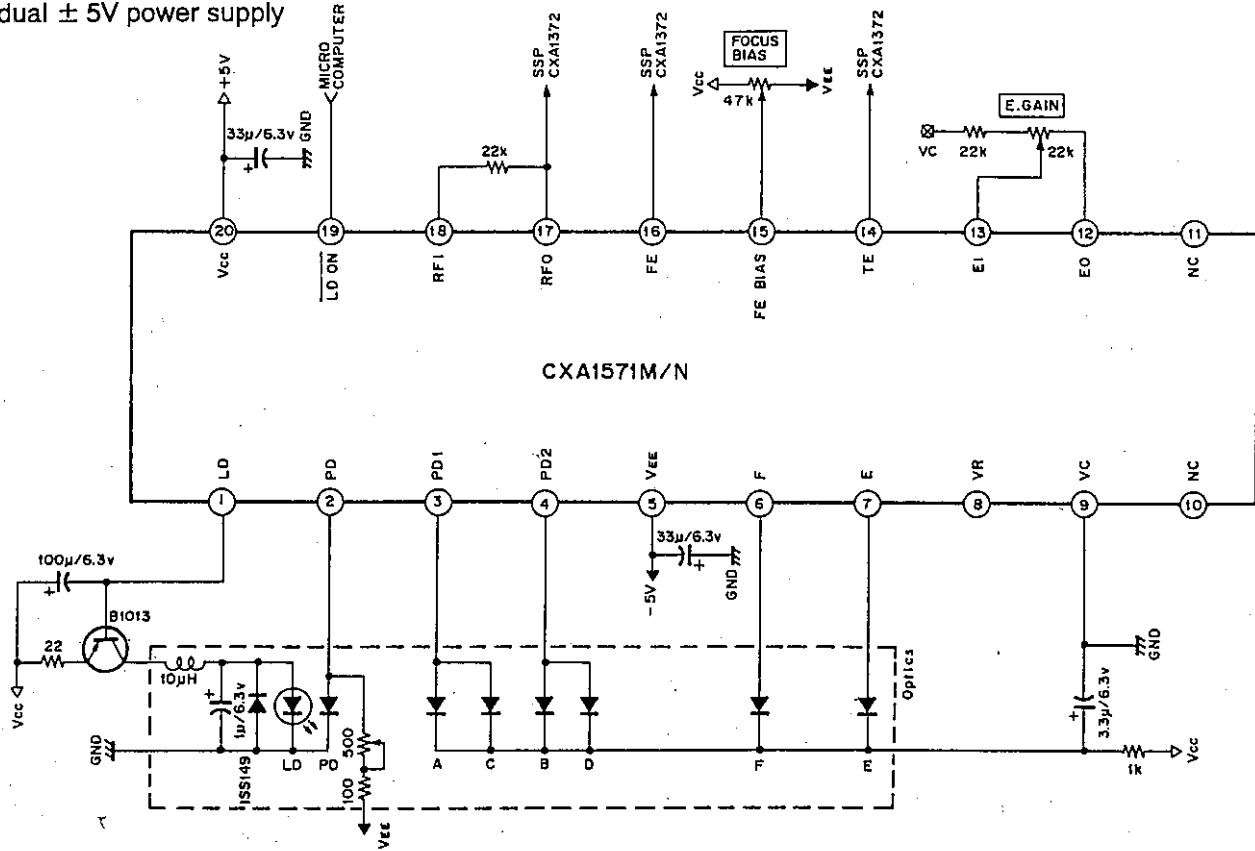

- For single +5V power supply

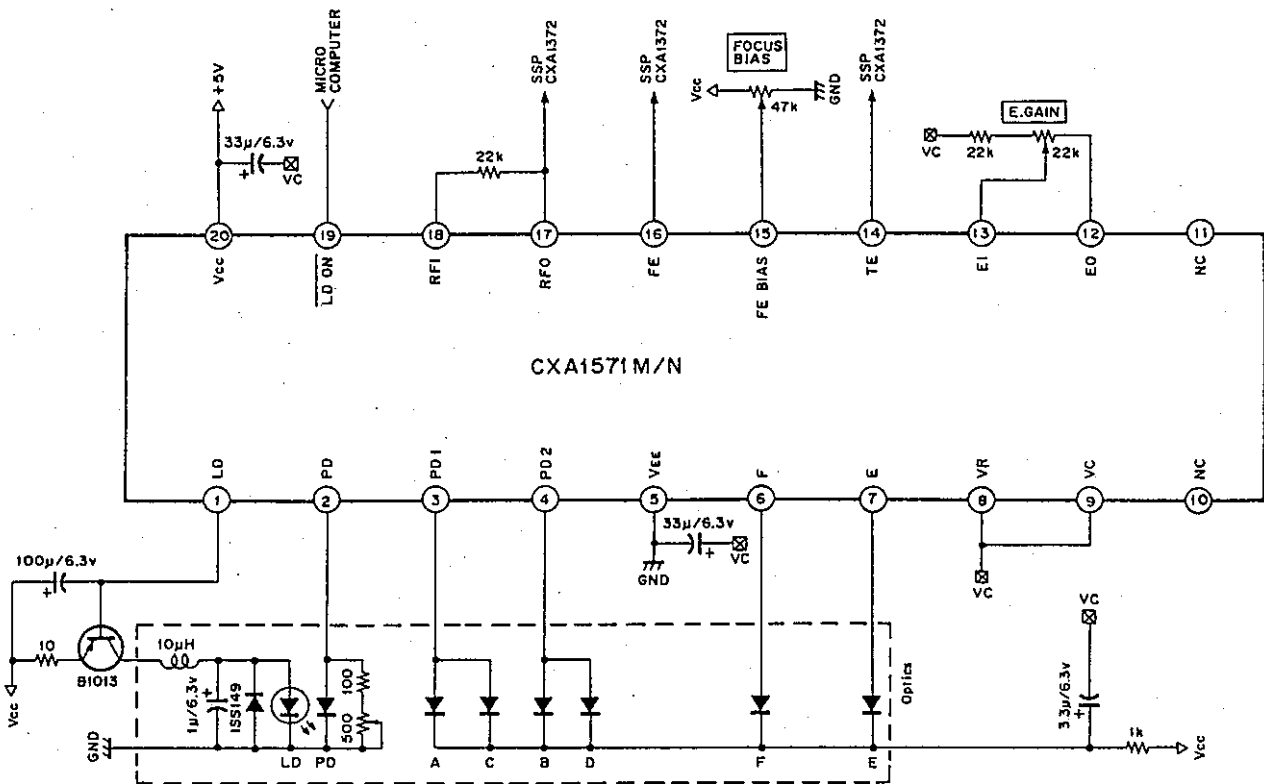

Description of Function
RF Amplifier

Photo diode current input to input pins (PD1 and PD2) is respectively converted to I-V in the PD I-V amplifier, by means of a 58kΩ equivalent resistance. Furthermore, it is added to RF summing amplifier and the output voltage, converted from photo diodes (A+B+C+D) current to voltage, is output to RFO pin. Eye-pattern check is possible through this pin.

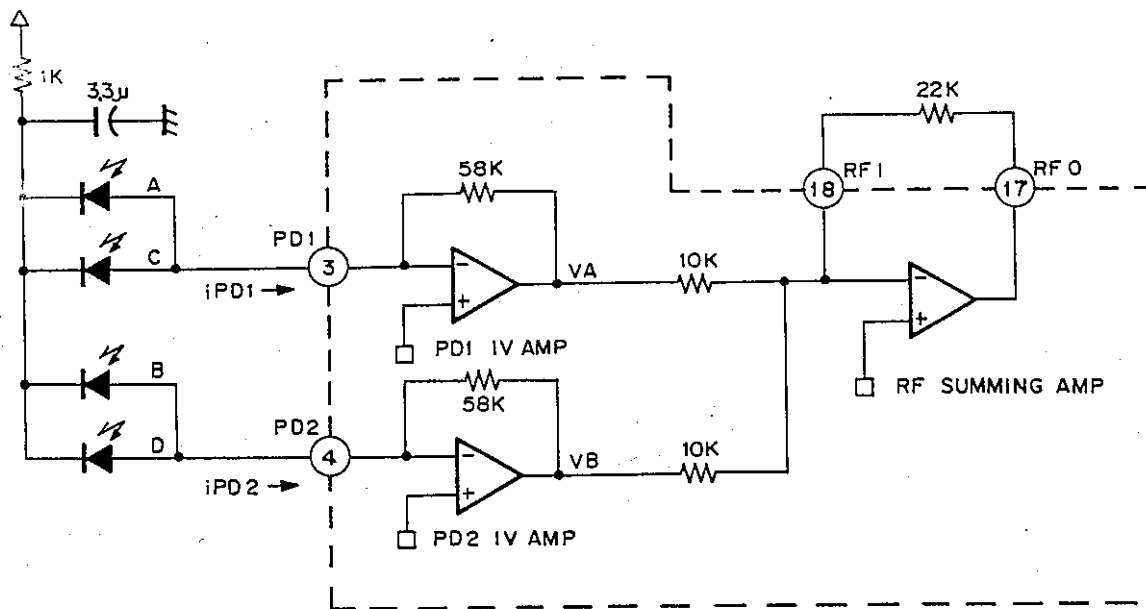

RFO output voltage low frequency turns to $V_{RFO} = 2.2 \times (V_A + V_B)$
 $= 127.6k\Omega \times (i_{PD1} + i_{PD2})$.

Focus Error Amplifier

The difference between outputs VA and VB of RF I-V amplifier is obtained to have the voltage converted from current to voltage of photo diodes (A+C-B-D) output.

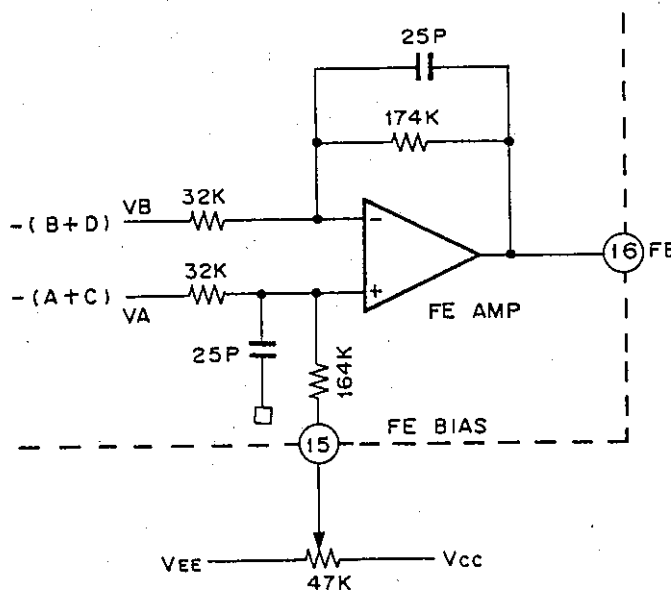

FE output voltage (low frequency) turns to $V_{FE} = 5.4 \times (V_A - V_B)$
 $= (i_{PD2} - i_{PD1}) \times 315k\Omega$.

Tracking Error Amplifier

Photo diode current input to Pins E and F is converted from current to voltage at IV amplifier of E and F respectively.

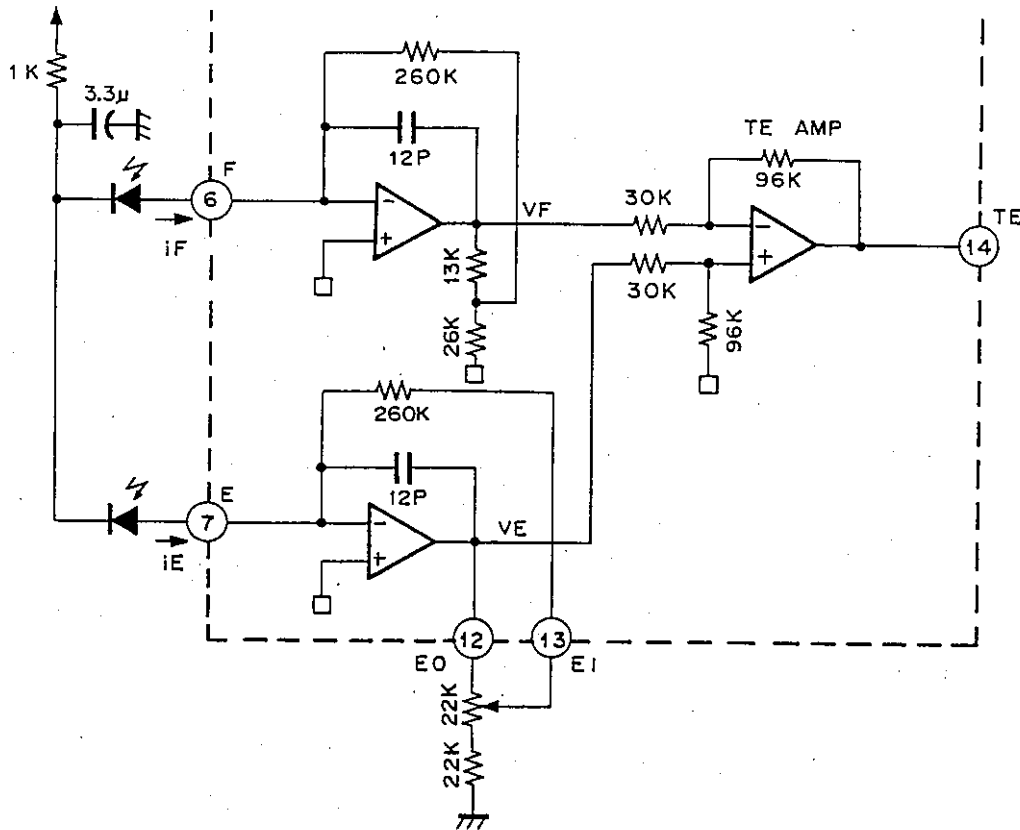

The difference between V_E and V_F is obtained at the tracking error amplifier. This amplifier output is the current difference between photo diodes E and F converted into voltage output.

$$V_{TE} = (V_E - V_F) \times 3.2$$

$$= (i_E - i_F) \times 1290k\Omega$$

Midpoint Voltage Generating Circuit

Supplies midpoint voltage when CXA1571 is used with single power supply. Maximum current stands around $\pm 3\text{mA}$ and output impedance at about $50\ \Omega$.

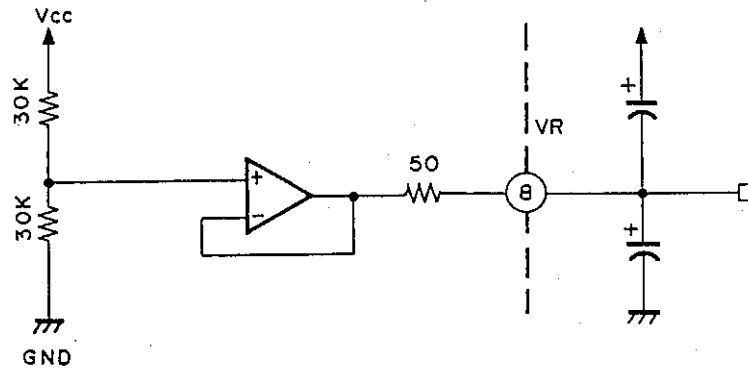

APC Circuit

As the laser diode has large negative temperature characteristics in optical output when driven with a constant current, the current must be controlled through the monitor photo diode, to obtain a constant output. This constitutes the APC circuit. Connecting LD ON pin to GND sets APC ON while connection to Vcc sets it OFF.

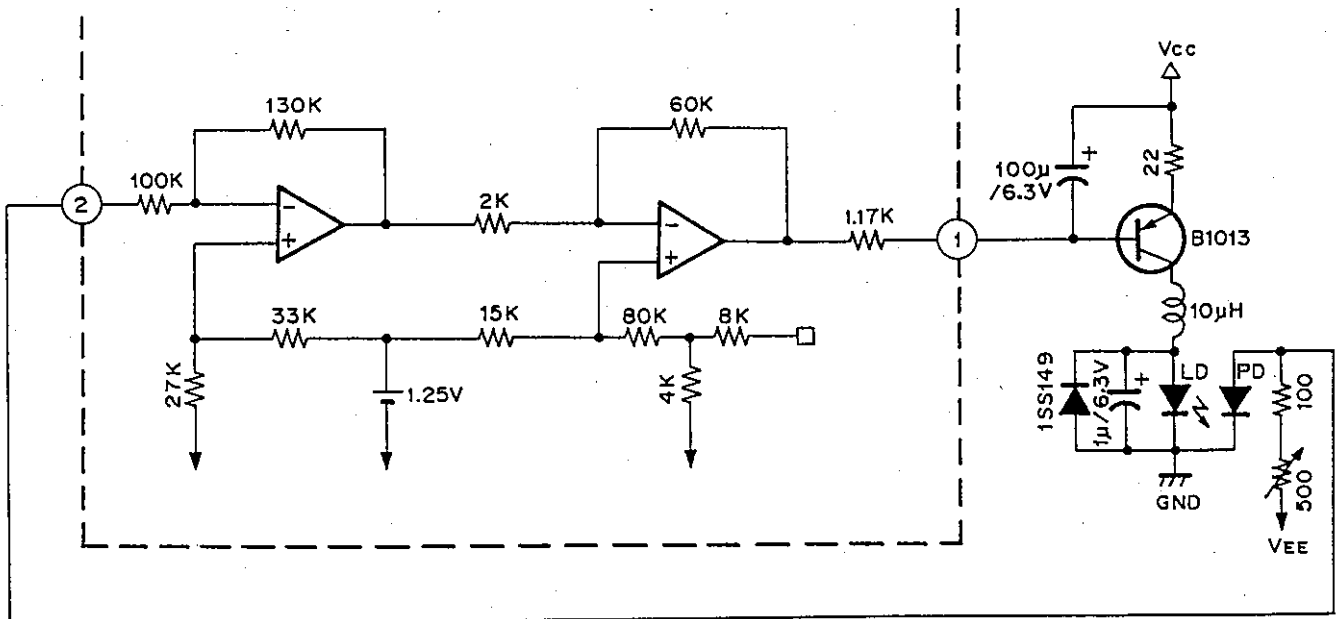

Notes on Operation

1. Power supply

The CXA1571 can be driven by either a dual or single power supply. Connections for the respective power supplies are shown in the chart below.

	Vcc	VEE	VR	VC
± 2 supply	+supply	-supply	OPEN	GND
Single supply	supply	GND	VC	VR

2. RF amplifier

Input pins PD1 and PD2 are at high impedance. When mounting, keep wiring as short as possible.

Package Outline Unit: mm

CXA1571M

20PIN SOP (PLASTIC)

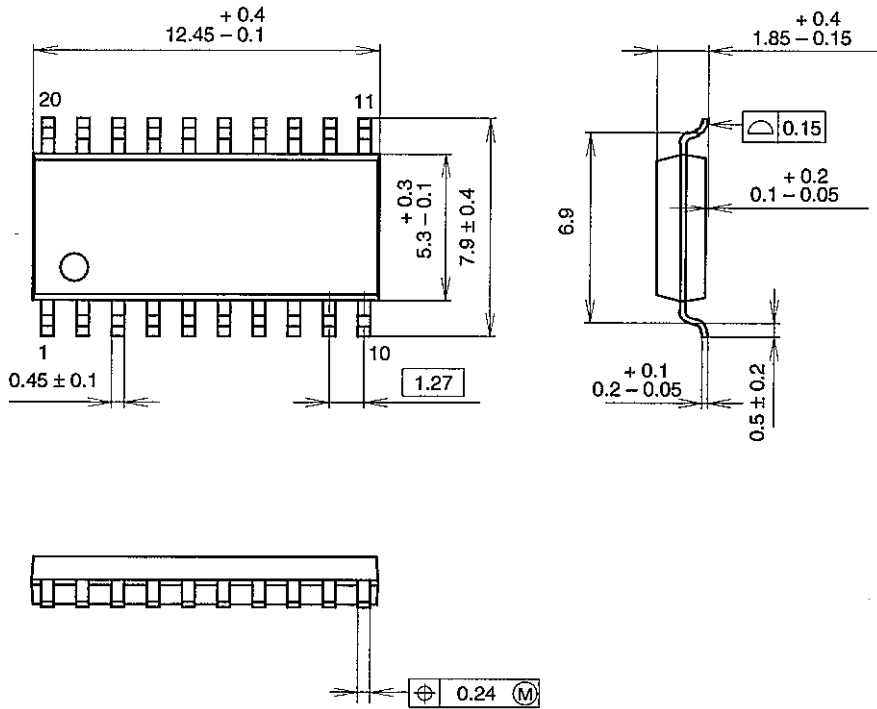

PACKAGE STRUCTURE

SONY CODE	SOP-20P-L01
EIAJ CODE	SOP020-P-0300
JEDEC CODE	_____

PACKAGE MATERIAL	EPOXY RESIN
LEAD TREATMENT	SOLDER PLATING
LEAD MATERIAL	COPPER ALLOY
PACKAGE MASS	0.3g

CXA1571M

20PIN SOP (PLASTIC)

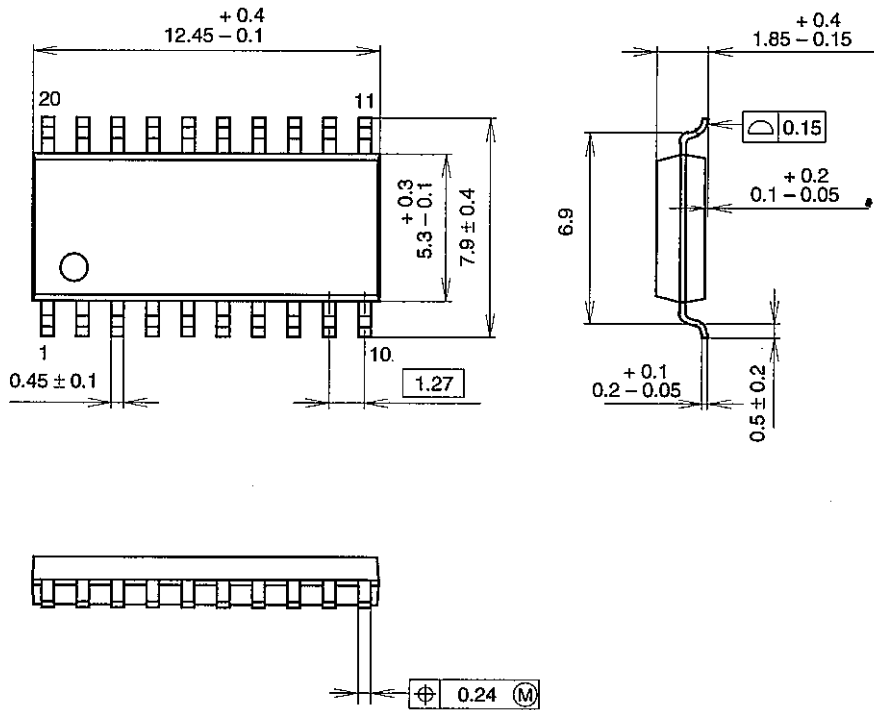

PACKAGE STRUCTURE

SONY CODE	SOP-20P-L01
EIAJ CODE	SOP020-P-0300
JEDEC CODE	_____

PACKAGE MATERIAL	EPOXY RESIN
LEAD TREATMENT	SOLDER PLATING
LEAD MATERIAL	COPPER ALLOY
PACKAGE MASS	0.3g

LEAD SPECIFICATIONS

ITEM	SPEC.
LEAD MATERIAL	COPPER ALLOY
SOLDER PLATING	Sn-Bi Bi:1-4wt%
LEAD TREATMENT THICKNESS	5-18 μ m

CXA1571N

20PIN SSOP (PLASTIC)

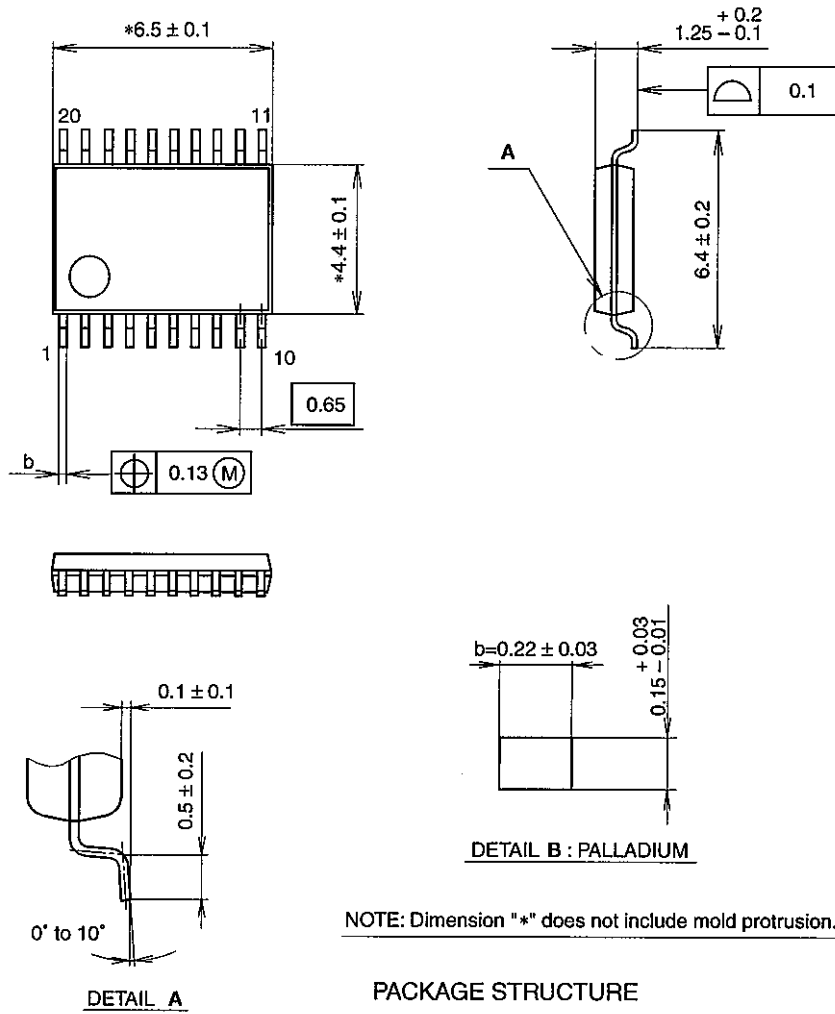

NOTE: Dimension "*" does not include mold protrusion.

PACKAGE STRUCTURE

SONY CODE	SSOP-20P-L01
EIAJ CODE	SSOP020-P-0044
JEDEC CODE	_____

PACKAGE MATERIAL	EPOXY RESIN
LEAD TREATMENT	PALLADIUM PLATING
LEAD MATERIAL	COPPER ALLOY
PACKAGE MASS	0.1g