

# STR-S6703 AND STR-S6704

## OFF-LINE SWITCHING REGULATORS – WITH BIPOLAR SWITCHING TRANSISTOR

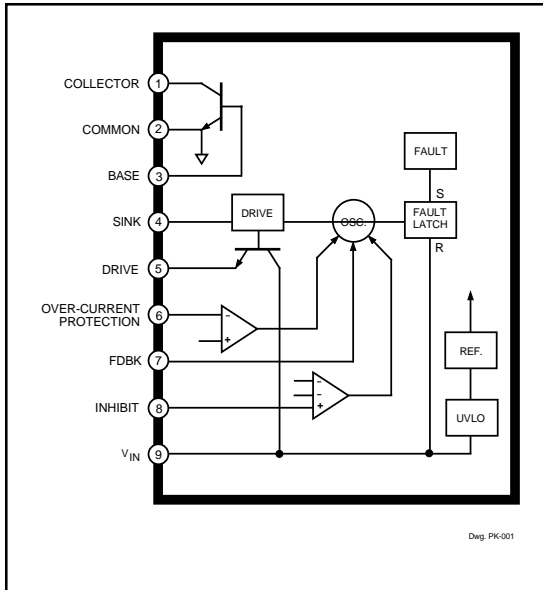

### ABSOLUTE MAXIMUM RATINGS

Supply Voltage, $V_{IN}$ .....	15 V
Output Voltage, $V_{CEX}$ .....	500 V
$V_{EBO}$ .....	7 V
Continuous Output Current, $I_C$ .....	See Table
1 ms Single-Pulse Output Current, $I_{CM}$ .....	See Table
Sink Current, $I_S$ .....	1.5 A
Drive Current, $I_D$ .....	-700 mA
Feedback Current, $I_{FDBK}$ .....	20 mA
Inhibit Voltage, $V_{INH}$ .....	15 V
Over-Current Protection Voltage Range, $V_{OCP}$ .....	$\pm 3.5$ V
Insulation Voltage, $V_{WM(RMS)}$ .....	2000 V
Package Power Diss., $P_D$ .....	See Graph
Output Junction Temperature, $T_J$ ..	+150°C
Internal Frame Temperature, $T_F$ ...	+125°C
Operating Temperature Range, $T_A$ .....	-20°C to +125°C
Storage Temperature Range, $T_{stg}$ .....	-40°C to +125°C

The STR-S6703 and STR-S6704 are specifically designed to meet the requirement for increased integration and reliability in off-line quasi-resonant flyback converters. These devices incorporate the primary control and proportional drive circuit with a third-generation high-voltage bipolar switching transistor.

Crucial system parameters such as maximum ON time and OFF time are fixed during manufacture. Local control circuit decoupling and layout are optimized within each device.

Cycle-by-cycle current limiting, under-voltage lock-out with hysteresis, over-voltage protection, and thermal shutdown protect these devices during all normal and overload conditions. Over-voltage protection and thermal shutdown are latched after a short delay. A versatile triple-level inhibit circuit includes the OFF time synchronization required to establish quasi-resonant operation. The inhibit function has also been expanded to initiate operation in stand-by mode in which the power supply delivers a small fraction of the steady-state output power. The dual requirements of dielectric isolation and low transient thermal impedance and steady-state thermal resistance are satisfied in an over-molded single-in-line power package.

Proven in substantial volumes, these devices and their fixed-frequency counterparts represent a significant advance in off-line SMPS reliability growth and integration. Similar devices, with an output voltage rating of 850 V and output power ratings to 220 W, are available as the STR-S6707 thru STR-S6709.

### FEATURES

- Quasi-Resonant Operation for Low EMI and High Efficiency
- Output Power to 140 W
- Low-Power Output Standby Mode
- Pulse-by-Pulse Over-Current Protection
- Latched Over-Voltage and Thermal Protection
- Third-Generation Switching Transistor with Proportional Drive
- Maximum ON Time and OFF Time Set During Manufacture
- Internal Under-Voltage Lockout with Hysteresis
- Over-Molded SIP with Integral Isolated Heat Spreader

Always order by complete part number:

Part Number	Max. Cont. Current, $I_C$	Peak Current, $I_{CM}$
STR-S6703	6 A	12 A
STR-S6704	5 A	10 A



**STR-S6703 AND STR-S6704**  
**OFF-LINE**  
**QUASI-RESONANT FLYBACK**  
**SWITCHING REGULATORS**

**ELECTRICAL CHARACTERISTICS at  $T_A = +25^\circ\text{C}$ ,  $V_{IN} = 8.5\text{ V}$ , voltage measurements are referred to Common (pin 2) (unless otherwise noted).**

Characteristic	Symbol	Test Conditions	Limits			
			Min.	Typ.	Max.	Units
On-State Voltage	$V_{INT}$	Turn-on, increasing $V_{IN}$	7.6	8.0	8.4	V
Under-Voltage Lockout	$V_{INQ}$	Turn-off, decreasing $V_{IN}$	4.6	4.9	5.2	V
Over-Voltage Threshold	$V_{OVP(th)}$		9.2	⌀	10.7	V
Output Leakage Current	$I_{CEX}$	$V_{CE} = 500\text{ V}$ , $V_{BE} = -1.5\text{ V}$	⌀	⌀	100	$\mu\text{A}$
Output Saturation Voltage	$V_{CE(sat)}$	STR-S6703, $I_C = 2\text{ A}$ , $I_B = 400\text{ mA}$	⌀	⌀	400	mV
		STR-S6704, $I_C = 2\text{ A}$ , $I_B = 400\text{ mA}$	⌀	⌀	TBD	mV
	$V_{BE(sat)}$	STR-S6703, $I_C = 2\text{ A}$ , $I_B = 400\text{ mA}$	⌀	⌀	1.5	V
		STR-S6704, $I_C = 2\text{ A}$ , $I_B = 400\text{ mA}$	⌀	⌀	TBD	V
DC Current Gain	$h_{FE}$	STR-S6703, $V_{CE} = 4\text{ V}$ , $I_C = 1\text{ A}$	23	⌀	46	⌀
		STR-S6704, $V_{CE} = 4\text{ V}$ , $I_C = 1\text{ A}$	20	⌀	50	⌀
Maximum ON Time	$t_{on}$		33	⌀	41	$\mu\text{s}$
Minimum OFF Time	$t_{off}$		45	⌀	55	$\mu\text{s}$
Over-Current Threshold	$V_{OCP(th)}$		-0.9	-1.0	-1.1	V
Feedback Threshold Volt.	$V_{FDBK(th)}$		⌀	650	⌀	mV
Inhibit Threshold Voltage	$V_{INH(th)}$	Oscillation stops	0.65	0.75	0.85	V
		Oscillation synchronized	⌀	1.4	2.0	V
		Oscillation stops (fault latch set)	3.2	5.1	5.6	V
Latch Holding Current	$I_{INH}$	$V_{IN}$ reduced from 10.7 V to 4 V	⌀	⌀	500	$\mu\text{A}$
Latch Reset Voltage	$V_Q$	$I_{IN} \leq 100\ \mu\text{A}$ , $V_{IN}$ reduced from 10.7 V	2.5	3.1	⌀	V
Supply Current	$I_{IN(ON)}$	Operating	15	⌀	28	mA
	$I_{IN(OFF)}$		⌀	⌀	200	$\mu\text{A}$
Insulation RMS Voltage	$V_{WM(RMS)}$	All terminals simultaneous reference metal plate against backside	2000	⌀	⌀	V
Thermal Shutdown	$T_J$		125	150	⌀	$^\circ\text{C}$
Thermal Resistance	$R_{\theta JM}$	Output junction to mounting surface	⌀	2.0	⌀	$^\circ\text{C/W}$

NOTES: Negative current is defined as coming out of (sourcing) the specified device terminal.  
 Typical Data is for design information only.

**STR-S6703 AND STR-S6704**  
**OFF-LINE**  
**QUASI-RESONANT FLYBACK**  
**SWITCHING REGULATORS**

**TYPICAL CHARACTERISTICS**

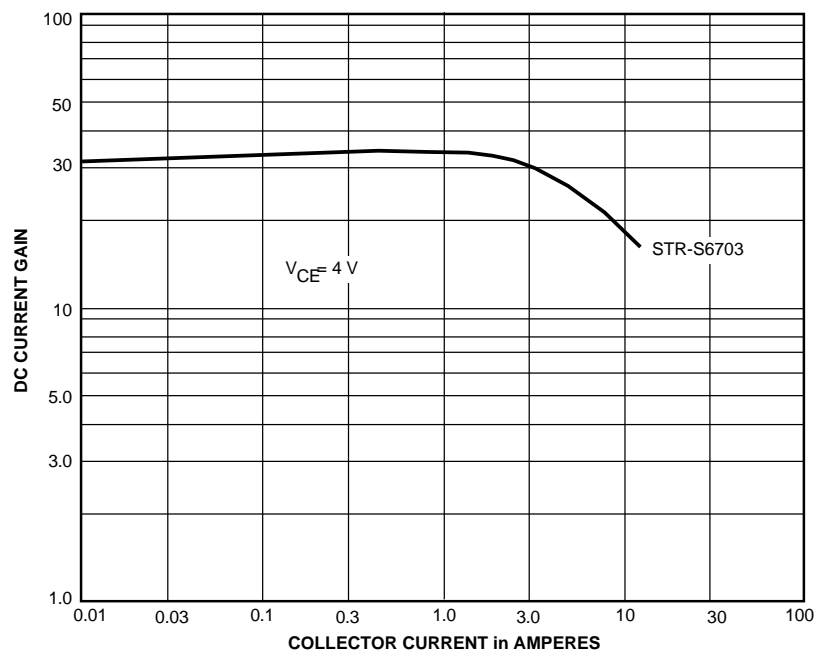

Dwg. GK-001-3

# STR-S6703 AND STR-S6704 OFF-LINE QUASI-RESONANT FLYBACK SWITCHING REGULATORS

## TYPICAL QUASI-RESONANT FLYBACK CONVERTER

**WARNING:** lethal potentials are present. See text.

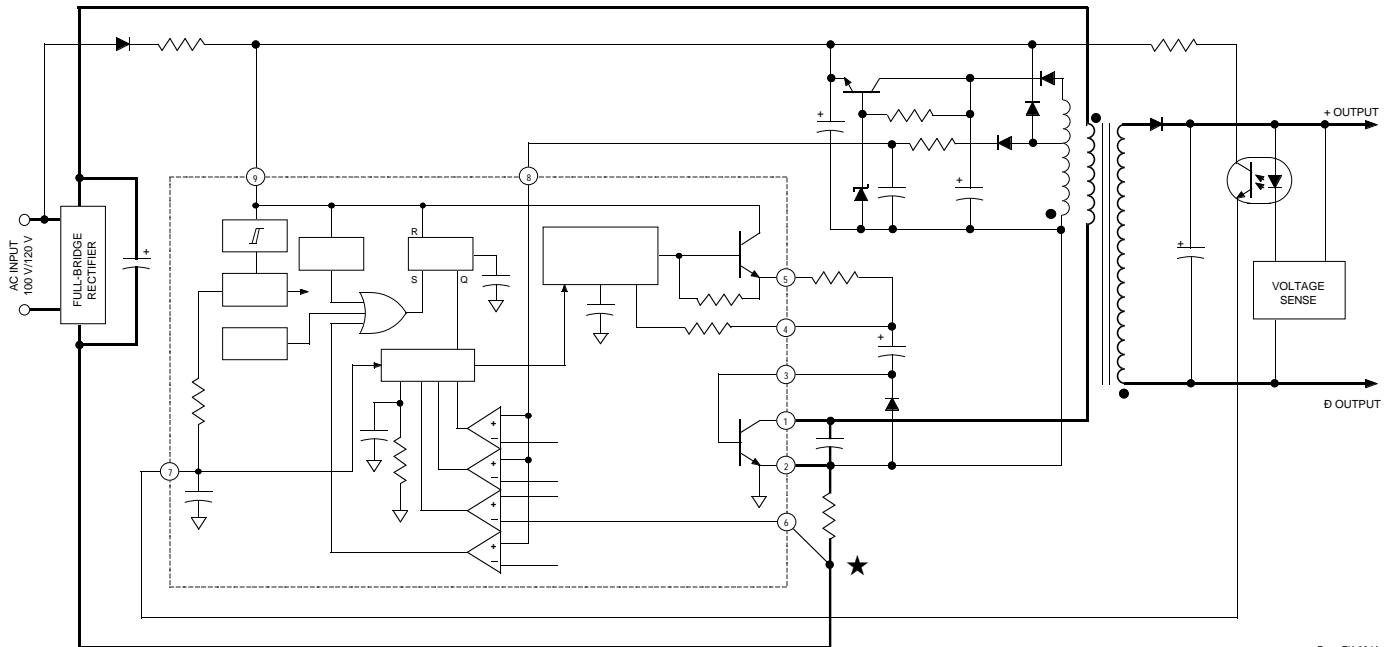

Dwg. EK-004A

## APPLICATIONS INFORMATION

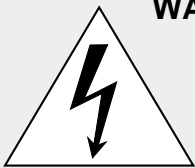

**WARNING** ⚡ These devices are designed to be operated at lethal voltages and energy levels. Circuit designs that embody these components must conform with applicable safety requirements. Precautions must be taken to prevent accidental contact with power-line potentials. Do not connect grounded test equipment.

The use of an isolation transformer is recommended during circuit development and breadboarding.

Recommended mounting hardware torque:

4.34 ⌀ 5.79 lbf⋅ft (6 ⌀ 8 kg⋅cm or 0.588 ⌀ 0.784 Nm).

Recommended metal-oxide-filled, alkyl-degenerated oil base, silicone grease:

Dow Corning 340, or equivalent

**STR-S6703 AND STR-S6704**  
**OFF-LINE**  
**QUASI-RESONANT FLYBACK**  
**SWITCHING REGULATORS**

**Dimensions in Inches**  
**(for reference only)**

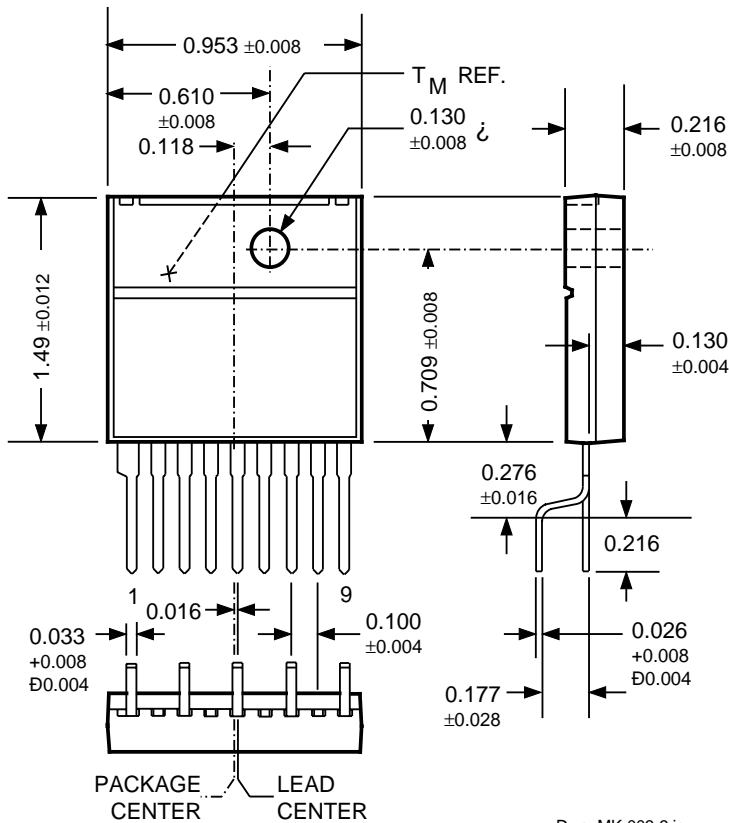

NOTE: Exact body and lead configuration at vendor's option within limits shown.

**STR-S6703 AND STR-S6704**  
**OFF-LINE**  
**QUASI-RESONANT FLYBACK**  
**SWITCHING REGULATORS**

**Dimensions in Millimeters**  
(controlling dimensions)

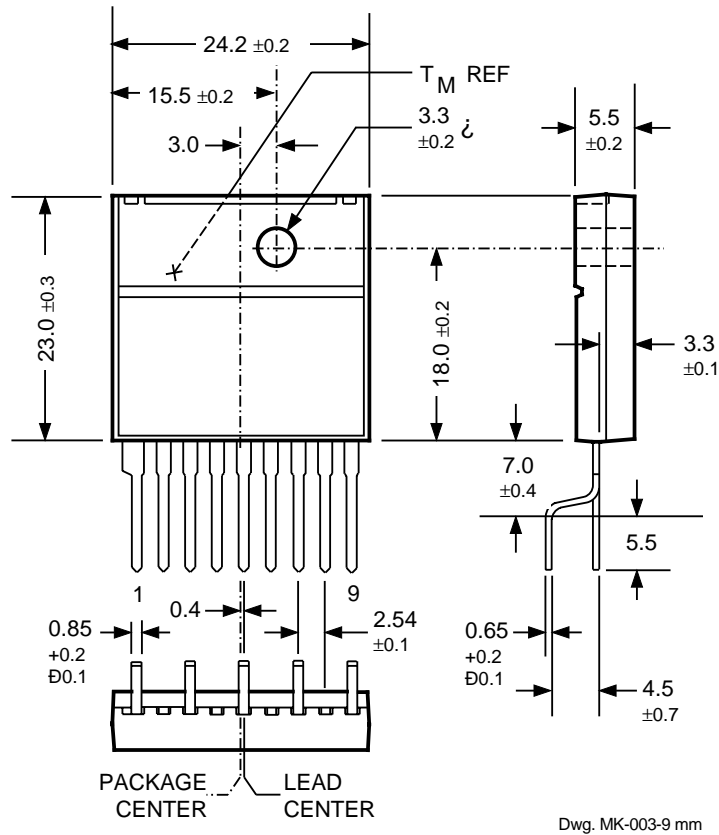

NOTE: Exact body and lead configuration at vendor's option within limits shown.

**STR-S6703 AND STR-S6704**  
**OFF-LINE**  
**QUASI-RESONANT FLYBACK**  
**SWITCHING REGULATORS**

*The products described here are manufactured in Japan by Sanken Electric Co., Ltd. for sale by Allegro MicroSystems, Inc.*

*Sanken Electric Co., Ltd. and Allegro MicroSystems, Inc. reserve the right to make, from time to time, such departures from the detail specifications as may be required to permit improvements in the performance, reliability, or manufacturability of their products. Therefore, the user is cautioned to verify that the information in this publication is current before placing any order.*

*These products are not authorized for use as critical components in life-support appliances, devices, or systems without express written approval.*

*The information included herein is believed to be accurate and reliable. However, Sanken Electric Co., Ltd. and Allegro MicroSystems, Inc. assume no responsibility for its use; nor for any infringements of patents or other rights of third parties which may result from its use.*



115 Northeast Cutoff, Box 15036  
Worcester, Massachusetts 01615-0036 (508) 853-5000

