

LM1886 TV Video Matrix D to A

General Description

The LM1886 is a TV video matrix D to A converter which encodes luminance and color difference signals from 3-bit red, green and blue inputs. The luminance output is encoded from the NTSC equation $Y = 0.3R + 0.59G + 0.11B$ and the R-Y and B-Y outputs are weighted to prevent over-modulation. A built-in R-Y and burst gate polarity switch allow European PAL compatible signals to be encoded. All output levels including an RF O Carrier Bias Voltage have been referenced to 5V for direct connection to the LM1889 TV video modulator. When used in combination with the LM1889 and a suitable sync generator, 3-bit, R, G and B information may be encoded to both composite video and RF channel carrier.

Features

- Complete digital to RF coding with LM1889
- 1-pin PAL/NTSC mode select
- True NTSC matrix
- 8 levels of grey scale
- Allows wide range of colorimetry
- Low power TTL inputs
- Wideband luminance output
- Weighted R-Y, B-Y outputs

Connection Diagram

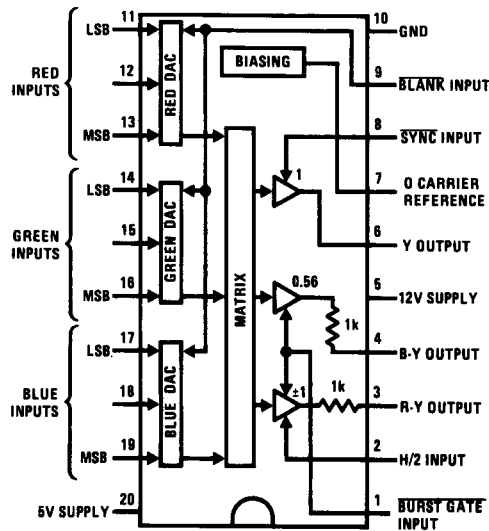

TL/H/7916-1

Top View
FIGURE 1

Order Number LM1886N
See NS Package Number N20A

Absolute Maximum Ratings

If Military/Aerospace specified devices are required, please contact the National Semiconductor Sales Office/Distributors for availability and specifications.

Supply Voltage	
Pin 5	15V
Pin 20	6V
Input Voltage (Pins 1, 8, 9, 11-19)	-0.5V, +12V

Pin 2 Voltage Relative to Pin 20	0.8V
Output Current	5 mA
Power Dissipation, $T_A = 25^\circ\text{C}$ (Note 1)	1900 mW
Storage Temperature Range	-55°C to +150°C
Operating Temperature Range	0°C to +70°C
Lead Temperature (Soldering, 10 sec.)	260°

Electrical Characteristics $T_A = 25^\circ\text{C}$, (Figure 2, Note 2)

Parameter	Conditions	Min	Typ	Max	Units
5V Supply Current (Pin 20)	$\overline{\text{BLANK}} = 0.8\text{V}$	7	11	16	mA
12V Supply Current (Pin 5)	$\overline{\text{BLANK}} = 0.8\text{V}$	9	13	17	mA
Logic "1" Input Current (Pins 1, 2, 8, 9, 11-19)	Input Voltage = 5.0V		0	10	μA
Logic "0" Input Current (Pins 1, 2, 8, 9, 11-19)	Input Voltage = 0.3V		-0.01	-0.18	mA
Output Offsets ΔV_Y ΔV_{R-Y} ΔV_{B-Y}	R, G, B, = 0.8V		0	± 50	mV
R-Y Full Scale, $(\Delta V_{R-Y})_{FS}$	R = 2V; G, B = 0.8V	1.0	1.23	1.4	V
B-Y Full Scale, $(\Delta V_{B-Y})_{FS}$	B = 2V; R, G = 0.8V	0.7	0.87	1.0	V
Green Full Scale ΔV_{R-Y} ΔV_{B-Y}	G = 2V; R, B = 0.8V	-0.85 -0.45	-1.03 -0.58	-1.2 -0.7	V
Y Full Scale $(\Delta V_Y)_{FS}$ ΔV_{R-Y} ΔV_{B-Y}	R, G, B = 2V	1.6	1.75	1.9	V
O Carrier Reference, ΔV_O		2.0	2.2	2.5	V
Blanking Level, ΔV_Y	$\overline{\text{BLANK}} = 0.8\text{V}$		0	± 50	mV
Sync Level, ΔV_Y	$\overline{\text{BLANK}}, \overline{\text{SYNC}} = 0.8\text{V}$	-0.67	-0.77	-0.87	V
NTSC Burst, ΔV_{B-Y}	$\overline{\text{BLANK}}, \overline{\text{BURST GATE}} = 0.8\text{V}$	-0.26	-0.35	-0.46	V
PAL Burst ΔV_{R-Y} ΔV_{B-Y}	SW in PAL Position; $\overline{\text{BLANK}}, \overline{\text{BURST GATE}},$ H/2 = 0.8V	-0.2 -0.2	-0.25 -0.25	-0.32 -0.32	V
PAL Inversion Ratio $(\Delta V_{R-Y})_{PAL}/(\Delta V_{R-Y})_{FS}$	R = 2V; G, B, H/2 = 0.8V SW to PAL Position	-0.9	-1.0	-1.1	
Y Linearity Error	Figure 2b Input Connection		± 1	± 6	%FS
Y Switching Times Rise Time, t_R Fall Time, t_F Settling Time ± 1 LSB	15 kHz Square Wave Switching R, G, B in Parallel		35 30 50		ns ns ns

Note 1: Above $T_A = 25^\circ\text{C}$, derate based on $T_{J(\text{MAX})} = 150^\circ\text{C}$ and $\theta_{JA} = 65^\circ\text{C/W}$.

Note 2: Unless otherwise noted, $\overline{\text{BLANK}}, \overline{\text{SYNC}}, \overline{\text{BURST GATE}} = 2\text{V}$ and SW is in NTSC position. All outputs are referenced to the +5V supply as shown in Figure 2a.

Typical Input and Output Waveforms

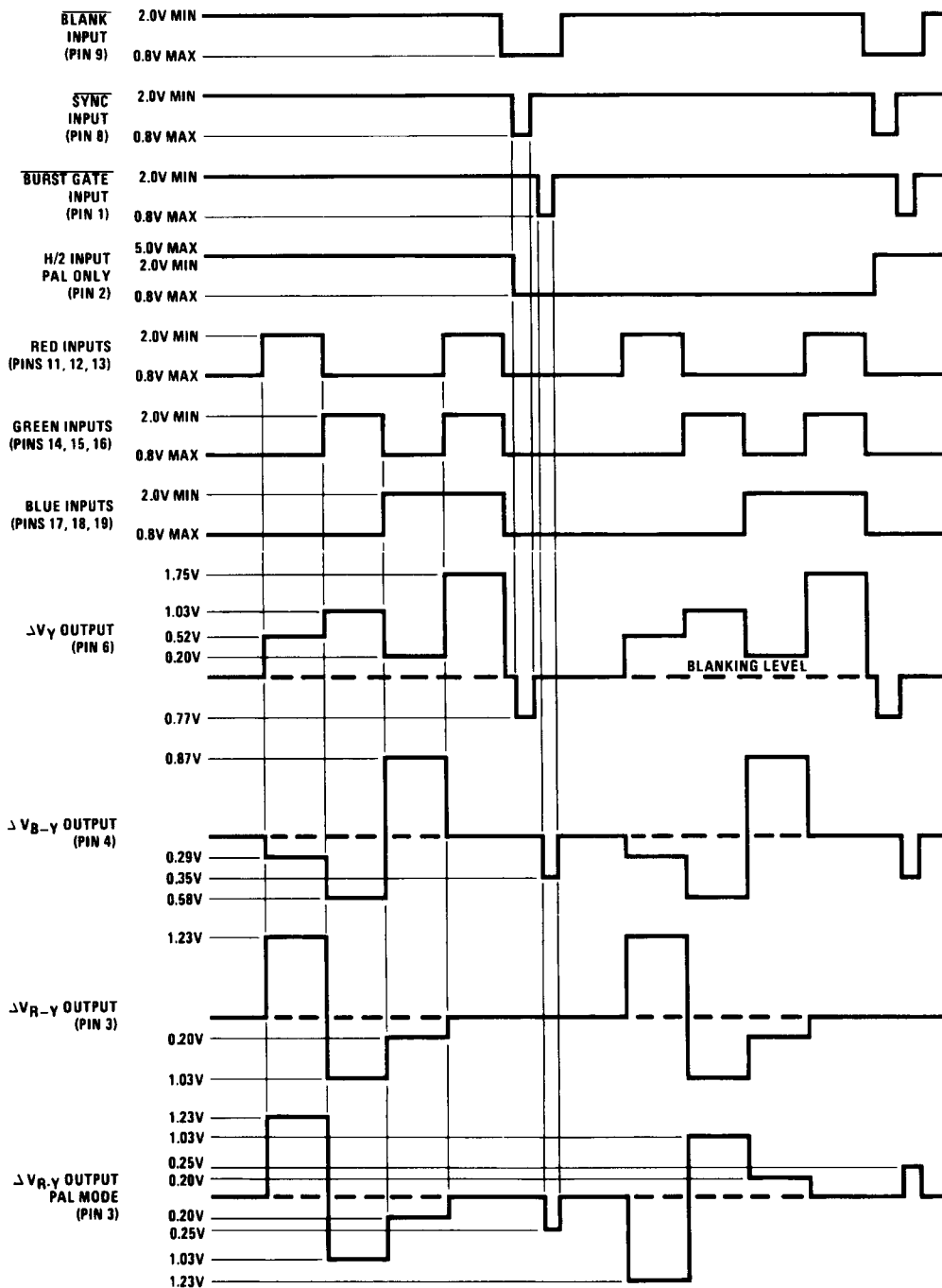

TL/H/7916-4

Test Circuits

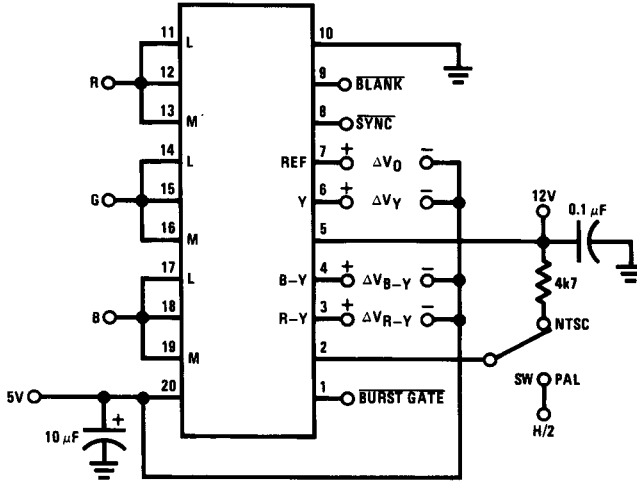

FIGURE 2a. 6-Color Input Connection

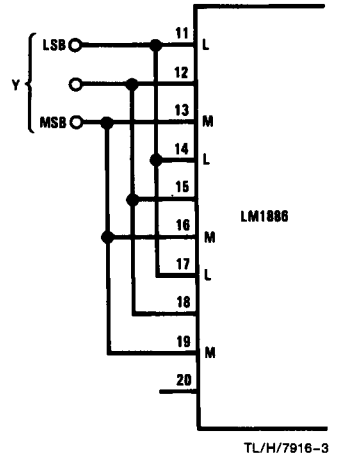

FIGURE 2b. 8-level Grey Scale Input Connection

TL/H/7916-2

TL/H/7916-3

Application Notes (Refer to Figure 3)

SYNC, BLANK, and BURST GATE may be obtained from a sync generator IC. For PAL operation, the H/2 square wave may be obtained by a ÷2 from horizontal sync.

All inputs are low-power TTL compatible. Because of the very low typical input currents, the color inputs may be paralleled in various combinations. For simple color requirements, the Figure 2a input connection may be used to produce the 6 primary and complementary colors listed in Table I, along with black and white. To add complex colors such as those at the bottom of Table I, all 9 input bits may be required separately. When choosing input codes for other colors, always check the new color against both light and dark backgrounds.

All outputs are referenced to the +5V supply for direct connection to the LM1889. The resistor on the luminance output pin 6 is used to sum the chroma subcarrier from the LM1889 and must be wired as tightly as possible to preserve the video bandwidth. For the addition of sound or a second RF channel, refer to the LM1889 data sheet.

TABLE I. Input Code Examples for Common Colors

		Input Code						
		Red		Green		Blue		
Color		M	L	M	L	M	L	
	Primary	Black	0	0	0	0	0	0
Dark Grey		0	1	0	0	1	0	
Light Grey		1	0	1	1	0	1	
White		1	1	1	1	1	1	
Red		1	1	1	0	0	0	
Green		0	0	0	1	1	1	
Blue		0	0	0	0	0	1	
Complementary		Cyan	0	0	0	1	1	1
		Magenta	1	1	1	0	0	0
		Yellow	1	1	1	1	1	1
	Brown	0	1	1	0	1	1	
Orange	1	1	1	1	0	0		
Flesh Tone	1	1	1	1	1	0		
Pink	1	1	1	1	1	0		
Sky Blue	1	0	1	1	0	1		

Typical Application

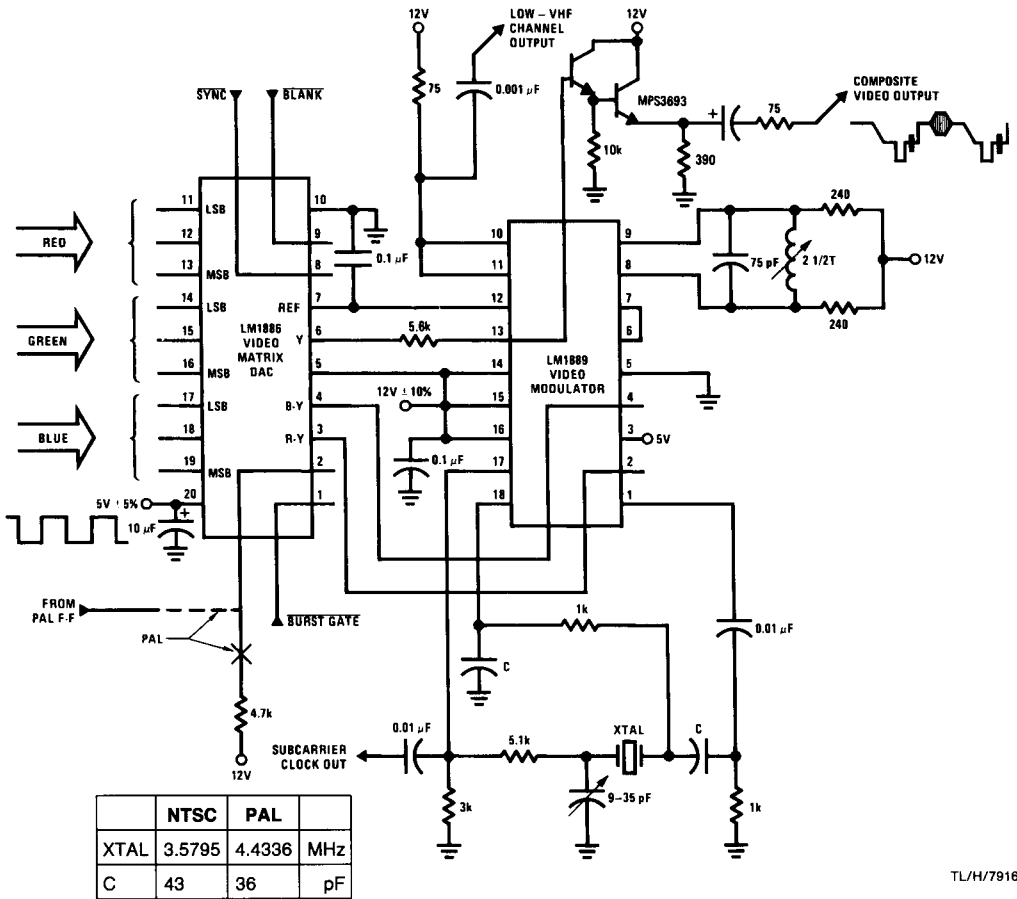

FIGURE 3

TL/H/7916-5

Circuit Description (Refer to Figure 4)

The 3-bit red, green, and blue inputs go to identical 3-bit current-mode digital-to-analog converters (DACs). Each DAC consists of three binary-weighted current sources controlled by diff-amp current switches. The DAC output currents are arbitrarily given a weighting factor of 0.59, which is the green coefficient in the luminance equation. Portions of the red and blue currents are split off, so that the remaining currents combined with the green current form the luminance current $I_Y = 0.3 I_R + 0.59 I_G + 0.11 I_B$. I_Y develops the luminance voltage V_Y across R_O in a summing amplifier referenced to the +5V supply. A current switch operated by pin 8 adds (-) sync pulses to the Y output at pin 6.

The portions of red and blue currents previously split off flow through resistors $R_O/0.29$ and $R_O/0.48$, which are weighted to form the red and blue voltages respectively. Since the opposite ends of the 2 resistors are connected to V_Y , the red and blue voltages across the resistors subtract from V_Y to develop the color difference voltages V_{Y-R} and V_{Y-B} . V_{Y-B} is coupled through a X.56 gain, 5V-referenced inverting amplifier to the B-Y output at pin 4. V_{Y-R} feeds parallel inverting and non-inverting unity gain amplifiers which allow either polarity to be coupled to the R-Y output pin 3. Switching between the 2 amplifiers is controlled by a current switch activated by the H/2 pin 2. A (-) burst gate pulse on pin 1 controls current switches which add the burst pulse components to the B-Y and R-Y outputs.

The requirements for PAL and NTSC encoding differ in the areas of burst gate operation and R-Y polarity, both of which are controlled via pin 2 as follows:

PAL, pin 2 fed by a half-line frequency TTL square wave—in this mode a PNP switch between pin 2 and +5V is held off continuously, which results in equal burst pulse components on the B-Y and R-Y outputs. In addition, the H/2 square wave causes the R-Y output polarity to reverse every line. (When fed to the LM1889 chroma modulator this causes the phase of the R-Y subcarrier to change 180° as required in PAL.)

NTSC, pin 2 tied through an external resistor to +12V—this turns on the PNP switch continuously, which eliminates the burst pulse on the R-Y output and increases the amplitude of the B-Y pulse. Since pin 2 is being held high, the R-Y output is locked in the positive polarity.

Blanking is activated by a low on pin 9, which de-biases the left side of the DAC diff-amps, so that $I_R = I_G = I_B = 0$ independent of the input states. When blanked, the Y, B-Y and R-Y outputs all go to +5V. An additional amplifier produces a 0 carrier reference voltage at pin 7 which is 25% above the peak white voltage on the Y output, relative to +5V.

