

HIGH CURRENT SWITCHING REGULATOR

- 4 A OUTPUT CURRENT
- 5.1 V TO 28 V OUTPUT VOLTAGE RANGE
- 0 TO 100 % DUTY CYCLE RANGE
- PRECISE ($\pm 3\%$) ON-CHIP REFERENCE
- SWITCHING FREQUENCY UP TO 120 KHZ
- VERY HIGH EFFICIENCY (UP TO 90 %)
- VERY FEW EXTERNAL COMPONENTS
- SOFT START
- RESET OUTPUT
- CURRENT LIMITING
- INPUT FOR REMOTE INHIBIT AND SYNCHRONOUS PWM
- THERMAL SHUTDOWN

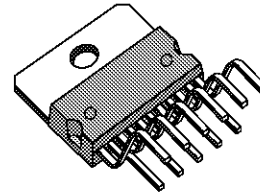
DESCRIPTION

The L4964 is a stepdown power switching regulator delivering 4A at a voltage variable from 5.1V to 28V.

Features of the device include overload protection, soft start, remote inhibit, thermal protection, a reset output for microprocessors and a PWM comparator input for synchronization in multichip configurations.

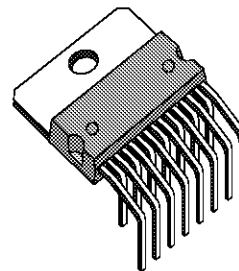
The L4964 is mounted in a 15-lead Multiwatt® plastic power package and requires very few external components.

Efficient operation at switching frequencies up to 120kHz allows a reduction in the size and cost of external filter components.



MULTIWATT15 Vertical
(Plastic Package)

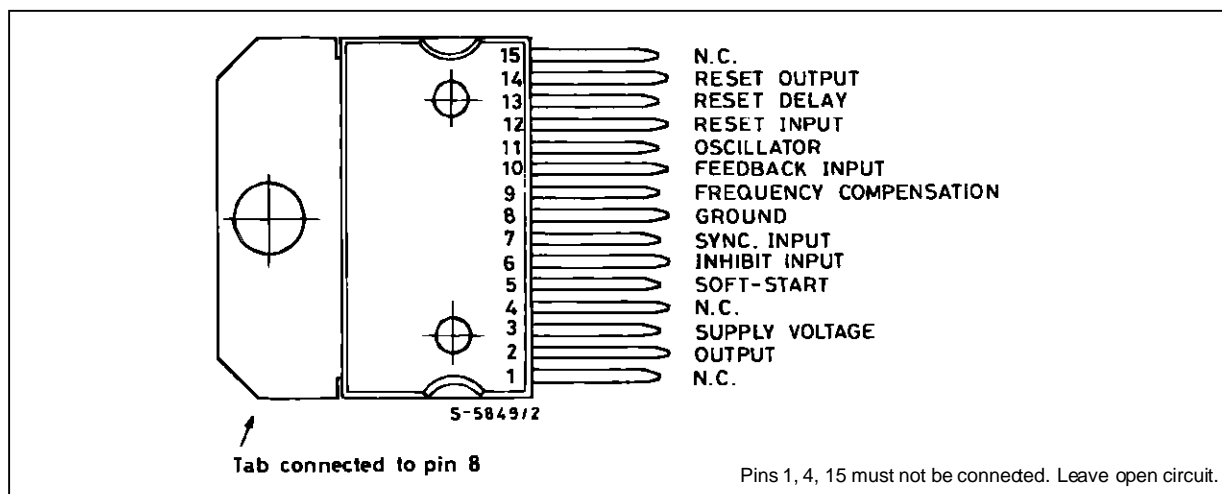
ORDERING NUMBER : L4964



MULTIWATT15 Horizontal
(Plastic Package)

ORDERING NUMBER : L4964HT

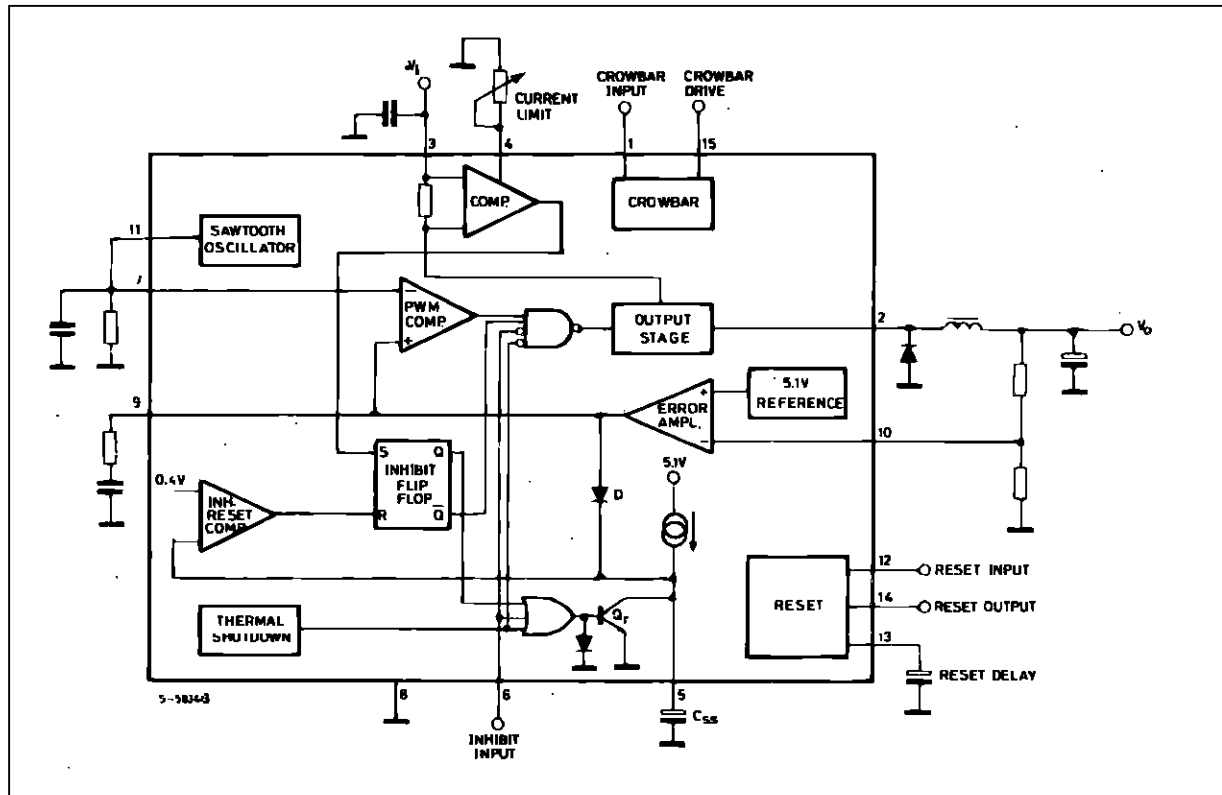
PIN CONNECTION (top view)



PIN FUNCTIONS

N°	Name	Function
1	N.C.	Must not be connected. Leave open circuit.
2	Output	Regulator Output.
3	Supply Voltage	Unregulated Voltage Input. An internal regulator powers the L4964's internal logic.
4	N.C.	Must not be connected. Leave open circuit.
5	Soft Start	Soft Start Time Constant. A capacitor is connected between this terminal and ground to define the soft start time constant. This capacitor also determines the average short circuit output current.
6	Inhibit Input	TTL - Level Remote Inhibit. A logic high level on this input disables the L4964.
7	Sync Input	Multiple L4964's are synchronized by connecting the pin 7 inputs together and omitting the oscillator RC network on all but one device.
8	Ground	Common Ground Terminal.
9	Frequency Compensation	A series RC network connected between this terminal and ground determines the regulation loop gain characteristics.
10	Feedback Input	The Feedback Terminal of the Regulation Loop. The output is connected directly to this terminal for 5.1 V operation ; it is connected via a divider for higher voltages.
11	Oscillator	A parallel RC network connected to this terminal determines the switching frequency. The pin must be connected to pin 7 input when the internal oscillator is used.
12	Reset Input	Input of the Reset Circuit. The threshold is roughly 5 V. It may be connected to the beedback point or via a divider to the input.
13	Reset Delay	A capacitor connected between this terminal and ground determines the reset signal delay time.
14	Reset Output	Open Collector Reset Signal Output. This output is high when the supply is safe.
15	N.C.	Must not be connected. Leave open circuit.

BLOCK DIAGRAM



CIRCUIT OPERATION (refer to the block diagram)

The L4964 is a monolithic stepdown switching regulator providing output voltages from 5.1 V to 28 V and delivering 4A.

The regulation loop consists of a sawtooth oscillator, error amplifier, comparator and the output stage. An error signal is produced by comparing the output voltage with a precise 5.1 V on-chip reference (zener zap trimmed to $\pm 3\%$). This error signal is then compared with the sawtooth signal to generate the fixed frequency pulse width modulated pulses which drive the output stage. The gain and frequency stability of the loop can be adjusted by an external RC network connected to pin 9. Closing the loop directly gives an output voltage of 5.1 V. Higher voltages are obtained by inserting a voltage divider.

Output overcurrents at switch on are prevented by the soft start function. The error amplifier output is initially clamped by the external capacitor C_{SS} and allowed to rise, linearly, as this capacitor is charged by a constant current source.

Output overload protection is provided in the form of a current limiter. The load current is sensed by an internal metal resistor connected to a comparator. When the load current exceeds a preset threshold this comparator sets a flip flop which disables the output stage and discharges the soft start capacitor.

A second comparator resets the flip flop when the voltage across the soft start capacitor has fallen to 0.4 V. The output stage is thus re-enabled and the output voltage rises under control of the soft start network. If the overload condition is still present the limiter will trigger again when the threshold current is reached. The average short circuit current is limited to a safe value by the dead time introduced by the soft start network.

The reset circuit generates an output signal when the supply voltage exceeds a threshold programmed by an external divider. The reset signal is generated with a delay time programmed by an external capacitor. When the supply falls below the threshold the reset output goes low immediately. The reset output is an open collector.

A TTL - level input is provided for applications such as remote on/off control. This input is activated by high level and disables circuit operation. After an inhibit the L4964 restarts under control of the soft start network.

The thermal overload circuit disables circuit operation when the junction temperature reaches about 150 and has hysteresis to prevent unstable conditions.

Figure 1 : Reset Output Waveforms

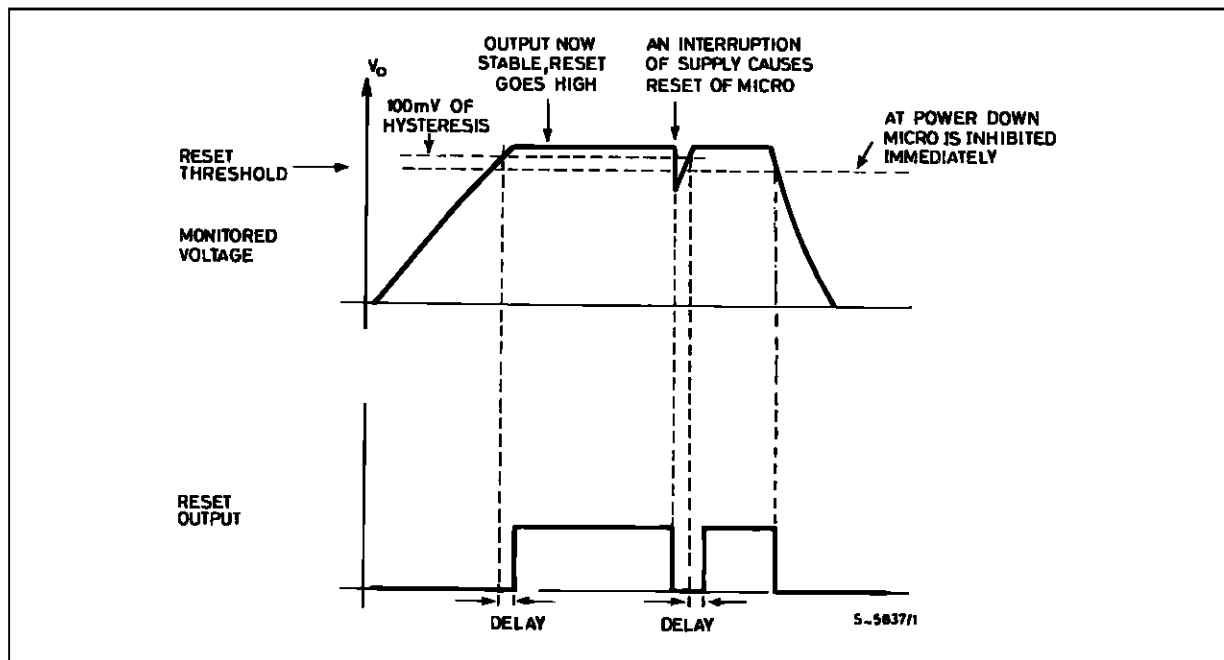


Figure 2 : Soft Start Waveforms

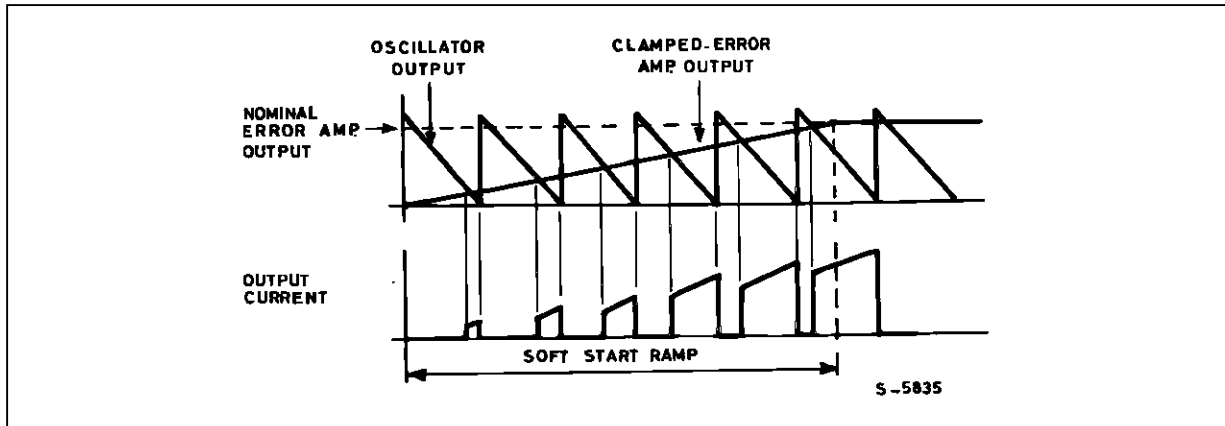
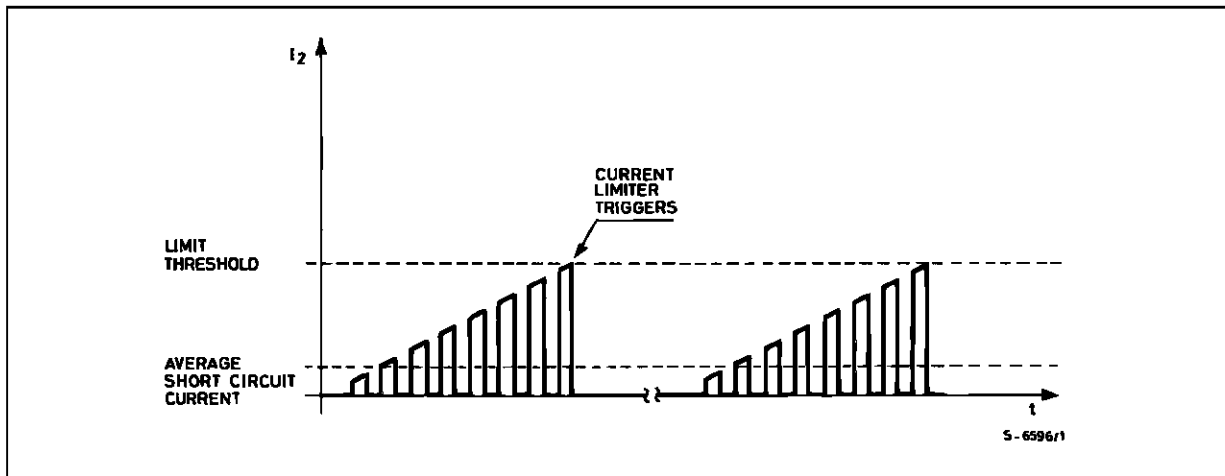


Figure 3 : Current Limiter Waveforms



ABSOLUTE MAXIMUM RATINGS

Symbol	Parameter	Value	Unit
V_i	Input Voltage (pin 3)	36	V
$V_i - V_2$	Input to Output Voltage Difference	38	V
V_2	Output DC Voltage Output Peak Voltage at $t = 0.1 \mu\text{sec}$ $f = 100 \text{ kHz}$	-1 -7	V V
V_{12}	Voltage at Pin 12	10	V
V_5, V_7, V_9	Voltage at Pins 5, 7 and 9	5.5	V
V_{10}, V_6, V_{13}	Voltage at Pins 10, 6 and 13	7	V
V_{14}	Voltage at Pin 14 ($I_{14} \leq 1 \text{ mA}$)	V_i	
I_9	Pin 9 Sink Current	1	mA
I_{11}	Pin 11 Source Current	20	mA
I_{14}	Pin 14 Sink Current ($V_{14} < 5 \text{ V}$)	50	mA
P_{tot}	Power Dissipation at $T_{\text{case}} \leq 90 \text{ }^\circ\text{C}$	20	W
T_j, T_{stg}	Junction and Storage Temperature	- 40 to 150	$^\circ\text{C}$

THERMAL DATA

Symbol	Parameter	Value	Unit
$R_{\text{th } j\text{-case}}$	Thermal Resistance Junction-case Max.	3	$^\circ\text{C/W}$
$R_{\text{th } j\text{-amb}}$	Thermal Resistance Junction-ambient Max.	35	$^\circ\text{C/W}$

ELECTRICAL CHARACTERISTICS(refer to the test circuits $T_j = 25^\circ\text{C}$, $V_i = 25\text{V}$, unless otherwise specified)

Symbol	Parameter	Test Conditions	Min.	Typ.	Max.	Unit	Fig.
DYNAMIC CHARACTERISTICS (pin 6 to GND unless otherwise specified)							
V_o	Output Voltage Range	$V_i = 36\text{V}$, $I_o = 1\text{A}$	V_{ref}		28	V	4
V_i	Input Voltage Range	$V_o = V_{ref}$ to 28V, $I_o = 3\text{A}$	9		36	V	4
ΔV_o	Line Regulation	$V_i = 10\text{V}$ to 30V, $V_o = V_{ref}$, $I_o = 2\text{A}$		15	70	mV	4
ΔV_o	Load Regulation	$I_o = 1\text{A}$ to 2A $I_o = 0.5\text{A}$ to 3A, $V_o = V_{ref}$		10 15	30 50	mV	4 4
V_{ref}	Internal Reference Voltage (Pin 10)	$V_i = 9\text{V}$ to 36V, $I_o = 2\text{A}$	4.95	5.1	5.25	V	4
$\frac{\Delta V_{ref}}{\Delta T}$	Average Temperature Coefficient of Reference Voltage	$T_j = 0^\circ\text{C}$ to 125°C , $I_o = 2\text{A}$		0.4		mV/ $^\circ\text{C}$	
V_d	Dropout Voltage between Pin 2 and Pin 3	$I_o = 3\text{A}$ $I_o = 2\text{A}$		2 1.5	3.2 2.4	V V	4 4
I_{om}	Maximum Operating Load Current	$V_i = 9\text{V}$ to 36V, $V_o = V_{ref}$ to 28V	4			A	4
I_{2L}	Current Limiting Threshold (Pin 2)	$V_i = 9\text{V}$ to 36V, $V_o = V_{ref}$ to 28V	4.5		8	A	4
I_{SH}	Input Average Current	$V_i = 36\text{V}$, Output Short-circuited		80	140	mA	4
η	Efficiency	$I_o = 3\text{A}$ $V_o = V_{ref}$ $V_o = 12\text{V}$		75 85		% %	4 4
SVR	Supply Voltage Ripple Rejection	$\Delta V_i = 2V_{rms}$, $f_{ripple} = 100\text{Hz}$ $V_o = V_{ref}$, $I_o = 2\text{A}$	46	56	–	dB	4
f	Switching Frequency		40	50	60	kHz	4
$\frac{\Delta f}{\Delta V_i}$	Voltage Stability of Switching Frequency	$V_i = 9\text{V}$ to 36V		0.5		%	4
$\frac{\Delta f}{\Delta T_j}$	Temperature Stability of Switching Frequency	$T_j = 0^\circ\text{C}$ to 125°C		1		%	4
f_{max}	Maximum Operating Switching Frequency	$V_o = V_{ref}$, $I_o = 1\text{A}$	120			kHz	–
T_{sd}	Thermal Shutdown Junction Temperature		135	145		$^\circ\text{C}$	–

DC CHARACTERISTICS

I_{3Q}	Quiescent Drain Current	$V_i = 36\text{V}$, $V_7 = 0\text{V}$, $S1 : B$, $S2 : B$ $V_6 = 0\text{V}$ $V_6 = 3\text{V}$		66 30	100 50	mA	6a
$-I_{2L}$	Output Leakage Current	$V_i = 36\text{V}$, $V_6 = 3\text{V}$, $V_7 = 0\text{V}$ $S1 : B$, $S2 : A$			2	mA	6a

SOFT START

I_{5so}	Source Current	$V_6 = 0\text{V}$, $V_5 = 3\text{V}$	80	130	180	μA	6b
I_{5si}	Sink Current	$V_6 = 3\text{V}$, $V_5 = 3\text{V}$	40	70	140	μA	6b

INHIBIT

V_{6L}	Low Input Voltage	$V_i = 9\text{V}$ to 36V, $V_7 = 0\text{V}$ $S1 : B$, $S2 : B$	- 0.3		0.8	V	6a
V_{6H}	High Input Voltage		2		5.5	V	6a
	Input Current with Input Voltage	$V_i = 9\text{V}$ to 36V, $V_7 = 0\text{V}$ $S1 : B$, $S2 : B$ $V_6 = 0.8\text{V}$ $V_6 = 2\text{V}$				μA	6a
$-I_{6L}$	Low Level				20		
$-I_{6H}$	High Level				10		

ERROR AMPLIFIER

V_{9H}	High Level Output Voltage	$V_{10} = 4.7\text{V}$, $I_9 = 100\mu\text{A}$, $S1 : A$, $S2 : A$	3.4			V	6c
V_{9L}	Low Level Output Voltage	$V_{10} = 5.3\text{V}$, $I_9 = 100\mu\text{A}$, $S1 : A$, $S2 : E$			0.6	V	6c
I_{9si}	Sink Output Current	$V_{10} = 5.3\text{V}$, $S1 : A$, $S2 : B$	100	150		μA	6c
$-I_{9so}$	Source Output Current	$V_{10} = 4.7\text{V}$, $S1 : A$, $S2 : D$	100	150		μA	6c

ELECTRICAL CHARACTERISTICS (continued)

(refer to the test circuits $T_j = 25^\circ\text{C}$, $V_i = 25\text{V}$, unless otherwise specified)

Symbol	Parameter	Test Conditions	Min.	Typ.	Max.	Unit	Fig.
--------	-----------	-----------------	------	------	------	------	------

ERROR AMPLIFIER (continued)

I_{10}	Input Bias Current	$V_{10} = 5.2\text{V}$, S1 : B		2	20	μA	6c
G_v	DC Open Loop Gain	$V_9 = 1\text{V}$ to 3V , S1 : A, S2 : C	40	55		dB	6c

OSCILLATOR AND PWM COMPARATOR

$-I_7$	Input Bias Current of PWM Comparator	$V_7 = 0.5\text{V}$ to 3.5V			10	μA	6a
$-I_{11}$	Oscillator Source Current	$V_{11} = 2\text{V}$, S1 : A, S2 : B	4		-	mA	6a

RESET

V_{12R}	Rising Threshold Voltage	$V_i = 9\text{V}$ to 36V , S1 : B, S2 : B	$V_{ref} - 150\text{mV}$	$V_{ref} - 100\text{mV}$	$V_{ref} - 50\text{mV}$	V	6d
V_{12F}	Falling Threshold Voltage		4.75	$V_{ref} - 150\text{mV}$	$V_{ref} - 100\text{mV}$	V	6d
V_{13D}	Delay Threshold Voltage	$V_{12} = 5.3\text{V}$, S1 : A, S2 : B	4.3	4.5	4.7	V	6d
V_{13H}	Delay Threshold Voltage Hysteresis			100		mV	6d
V_{14S}	Output Saturation Volt.	$I_{14} = 5\text{mA}$, $V_{12} = 4.7\text{V}$ - S1, S2 : B			0.4	V	6d
I_{12}	Input Bias Current	$V_{12} = 0\text{V}$ to V_{ref} , S1 : B, S2 : B		1	10	μA	6d
$-I_{13\text{so}}$ $I_{13\text{si}}$	Delay Source Current Delay Sink Current	$V_{13} = 3\text{V}$, S1 : A, S2 : B $V_{12} = 5.3\text{V}$ $V_{12} = 4.7\text{V}$	60 8	110	150	μA mA	6d
I_{14}	Output Leakage Current	$V_i = 36\text{V}$, $V_{12} = 5.3\text{V}$, S1 : B, S2 : A		100		μA	6d

Figure 4 : Dynamic Test Circuit

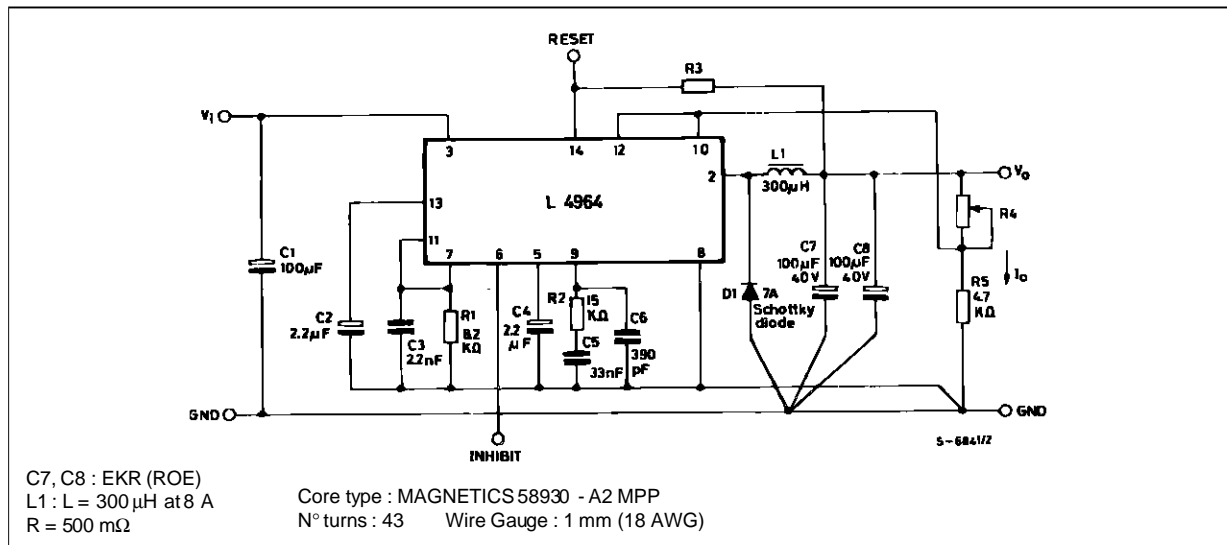


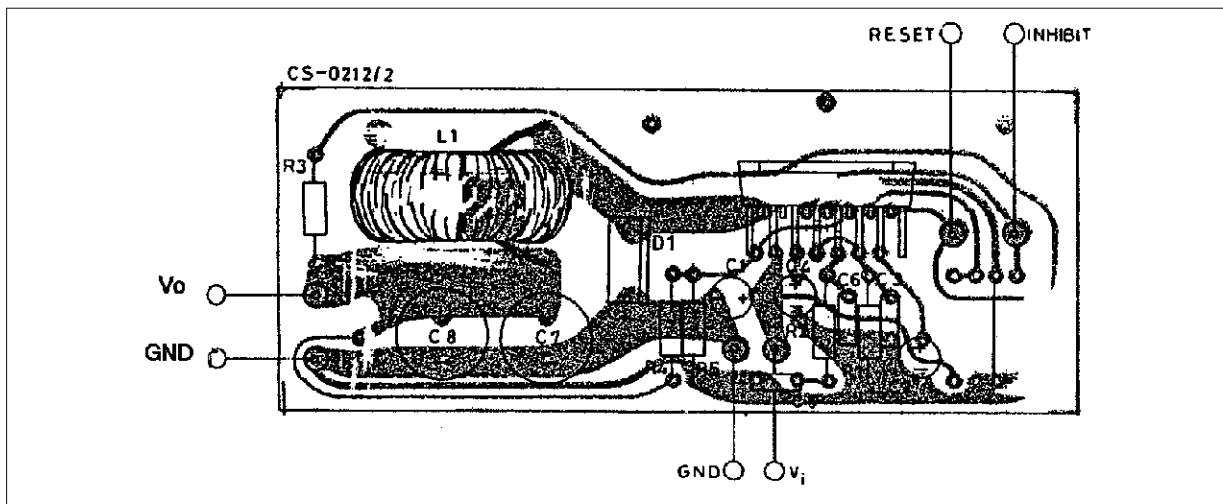
Figure 5 : PC. Board and Component Layout of the Circuit of Fig. 4 (1:1 scale)

Figure 6 : DC Test Circuits.

Figure 6a.

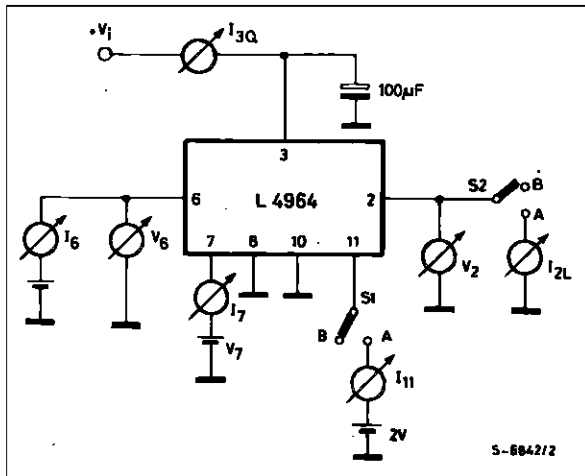


Figure 6b.

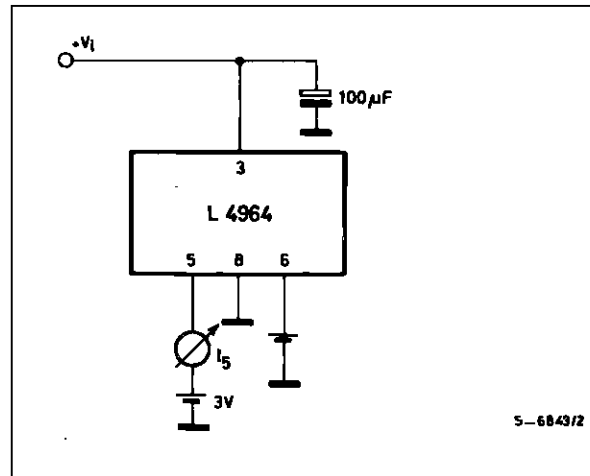


Figure 6c.

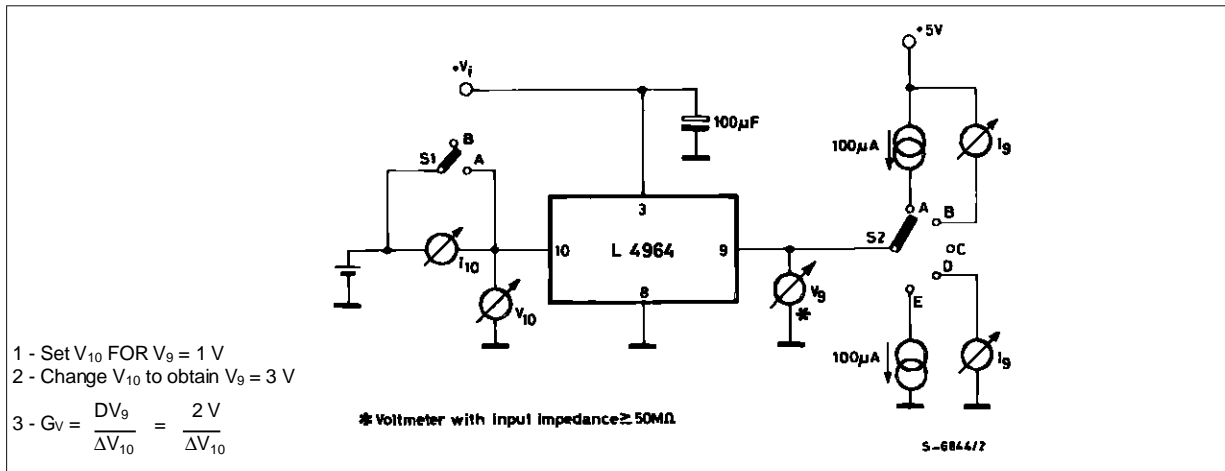


Figure 6d.

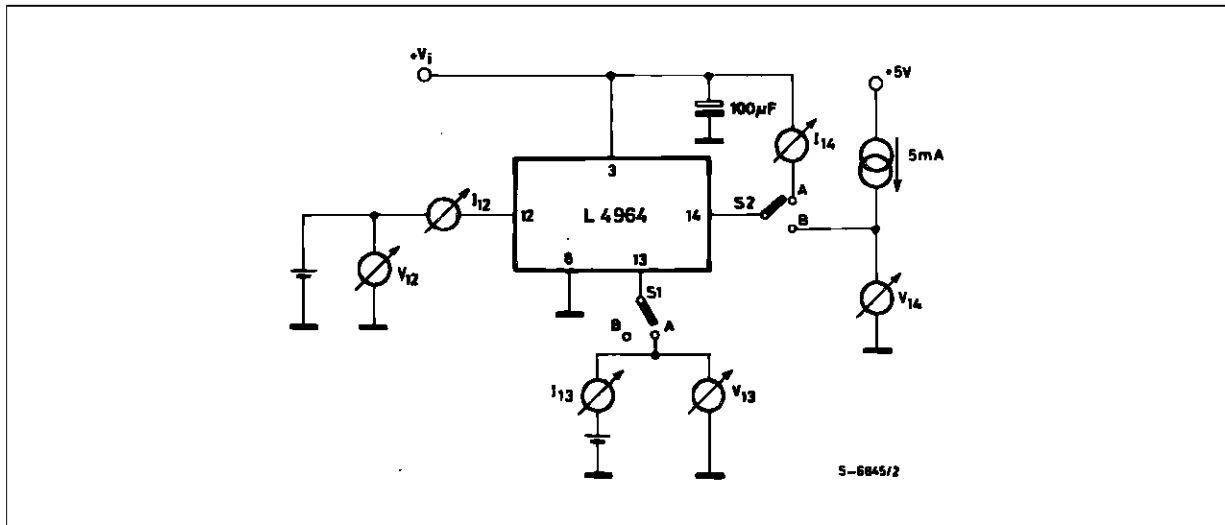


Figure 7 : Switching Frequency vs. R1 (see fig. 4).

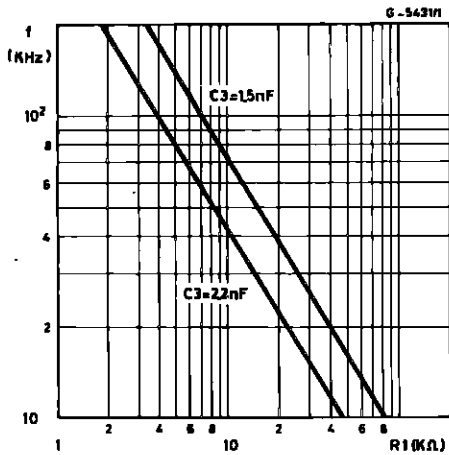


Figure 8 : Open Loop Frequency and Phase Response of Error Amplifier (see fig. 6c).

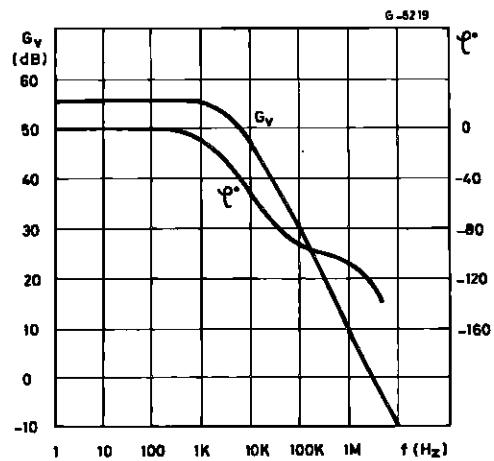


Figure 9 : Reference Voltage (pin 10) vs. Junction Temperature (see fig. 4).

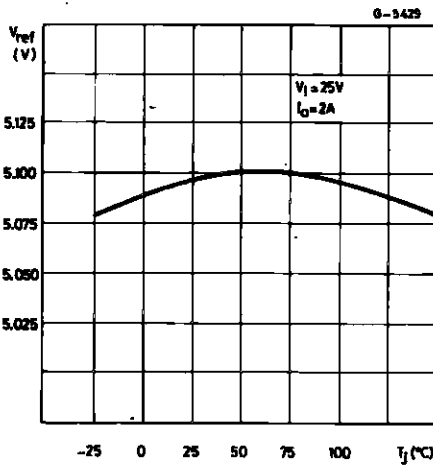


Figure 10 : Power Dissipation (L4964 only) vs. Input Voltage.

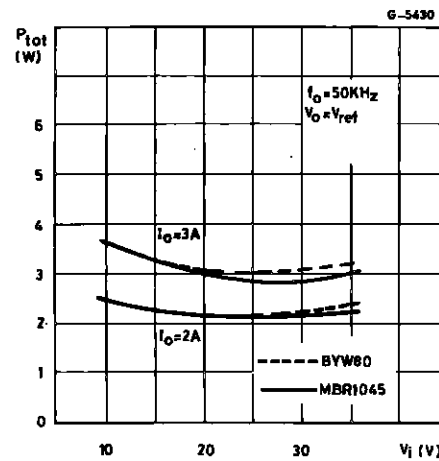


Figure 11 : Efficiency vs. Output Voltage.

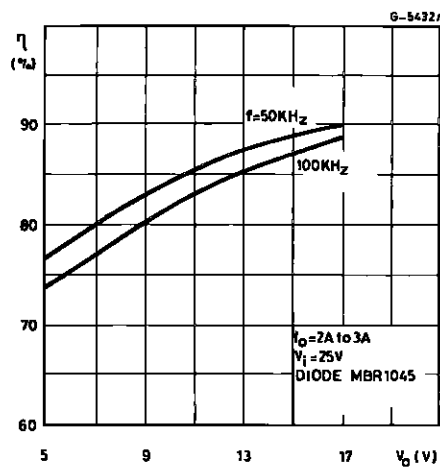
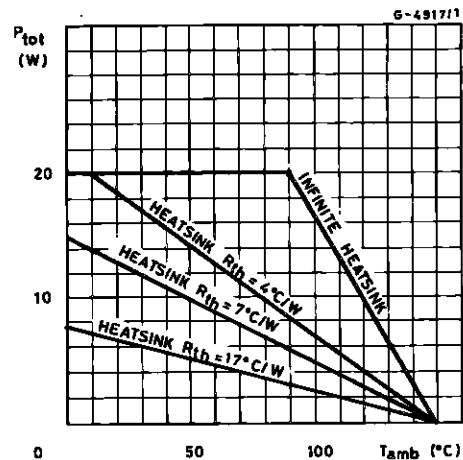


Figure 12 : Power Dissipation Derrating Curve.



APPLICATION INFORMATION

CHOOSING THE INDUCTOR AND CAPACITOR
 The input and output capacitors of the L4964 must have a low ESR and low inductance at high current ripple.

Preferably, the inductor should be a toroidal type or wound on a Moly-Permalloy nucleus. Saturation must not occur at current levels below 1.5 times the

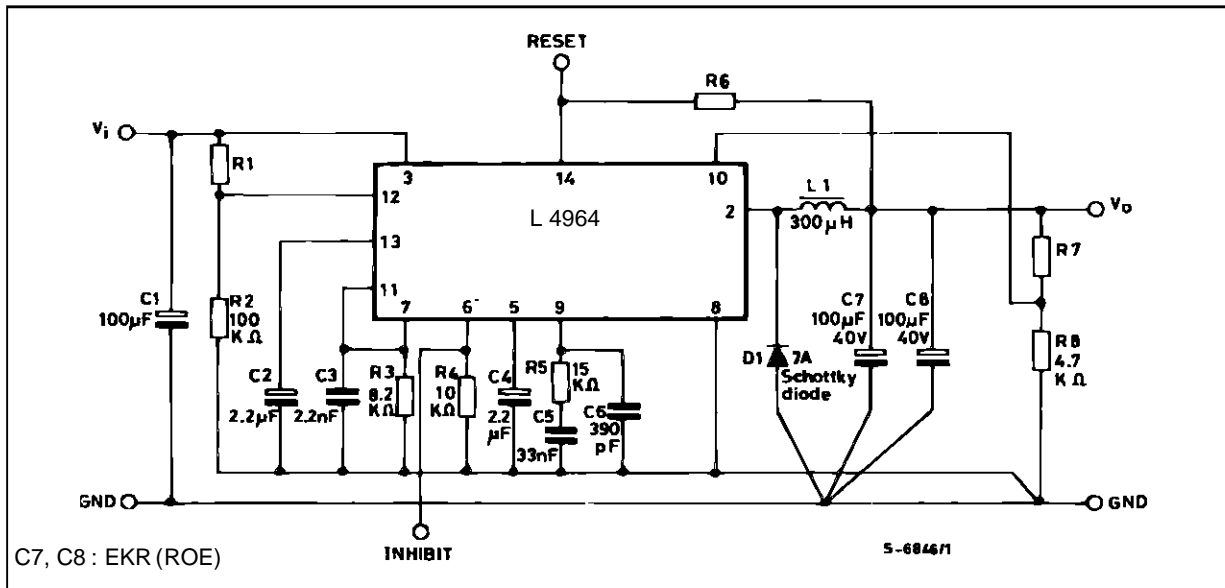
current limiter level. MPP nuclei have very soft saturation characteristics.

$$L = \frac{(V_i - V_o) V_o}{V_i f \Delta I_L}, \quad C = \frac{(V_i - V_o) V_o}{8L f^2 \Delta V_o}$$

ΔI_L = Inductance current ripple

ΔV_o = Output ripple voltage

Figure 13 : Typical Application Circuit.



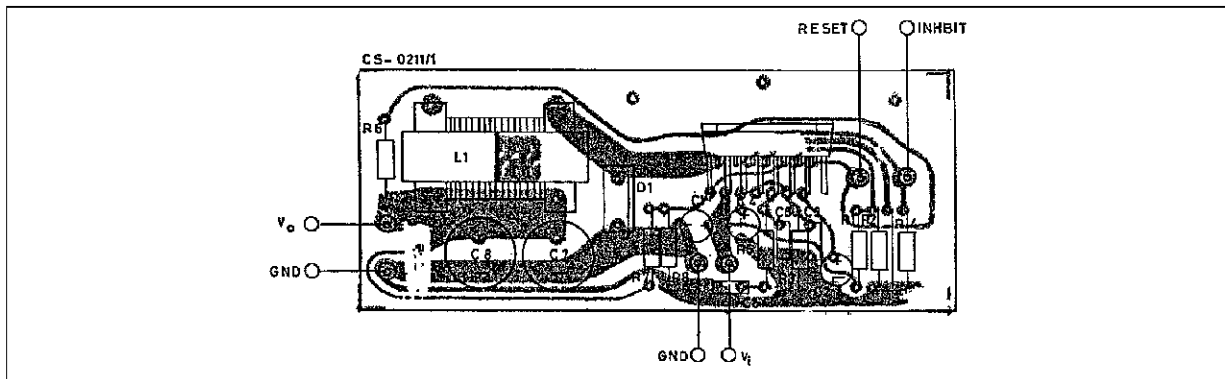
SUGGESTED INDUCTOR (L1)

Core Type	No Turns	Wire Gauge (mmm)	Air Gap (mm)
Magnetics 58930 – A2MPP	43	1.0	–
Thomson GUP 20 x 16 x 7	50	0.8	0.7
Siemens EC 35/17/10 (B6633& – G0500 – X127)	40	2 x 0.8	–

VOGT 250 µH Toroidal Coil, Part Number 5730501800

V_o	R8	R7
12 V	4.7 kΩ	6.2 kΩ
15 V	4.7 kΩ	9.1 kΩ
18 V	4.7 kΩ	12 kΩ

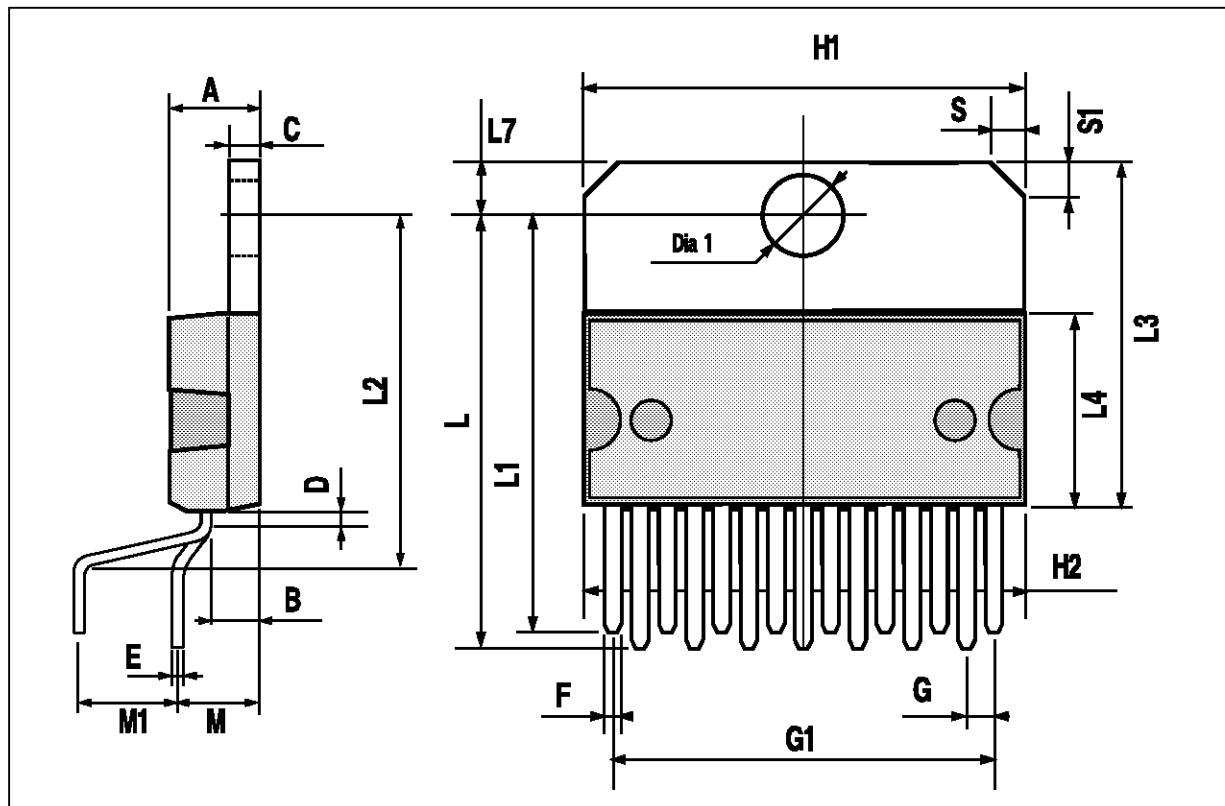
Figure 14 : P.C. Board and Component Layout of the Circuit of Fig. 13 (1:1 scale)



MULTIWATT15 (Vertical) PACKAGE MECHANICAL DATA

Dimensions	Millimeters			Inches		
	Min.	Typ.	Max.	Min.	Typ.	Max.
A			5			0.197
B			2.65			0.104
C			1.6			0.063
D		1			0.039	
E	0.49		0.55	0.019		0.022
F	0.66		0.75	0.026		0.030
G	1.14	1.27	1.4	0.045	0.050	0.055
G1	17.57	17.78	17.91	0.692	0.700	0.705
H1	19.6			0.772		
H2			20.2			0.795
L	22.1		22.6	0.870		0.890
L1	22		22.5	0.866		0.886
L2	17.65		18.1	0.695		0.713
L3	17.25	17.5	17.75	0.679	0.689	0.699
L4	10.3	10.7	10.9	0.406	0.421	0.429
L7	2.65		2.9	0.104		0.114
M	4.2	4.3	4.6	0.165	0.169	0.181
M1	4.5	5.08	5.3	0.177	0.200	0.209
S	1.9		2.6	0.075		0.102
S1	1.9		2.6	0.075		0.102
Dia. 1	3.65		3.85	0.144		0.152

MUL15V.TBL

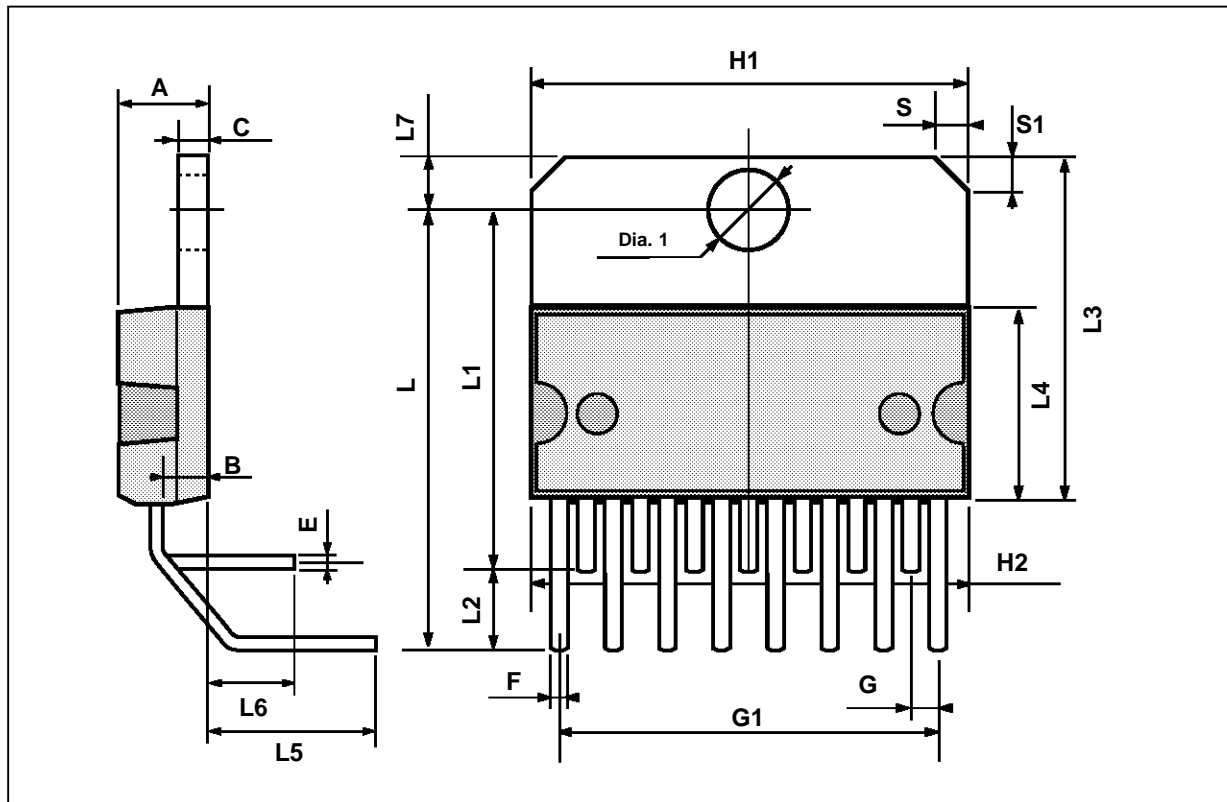


PMMUL15V.EPS

MULTIWATT15 (Horizontal) PACKAGE MECHANICAL DATA

Dimensions	Millimeters			Inches		
	Min.	Typ.	Max.	Min.	Typ.	Max.
A			5			0.197
B			2.65			0.104
C			1.6			0.063
E	0.49		0.55	0.019		0.022
F	0.66		0.75	0.026		0.030
G	1.14	1.27	1.4	0.045	0.050	0.055
G1	17.57	17.78	17.91	0.692	0.700	0.705
H1	19.6			0.772		
H2			20.2			0.795
L		20.57			0.810	
L1		18.03			0.710	
L2		2.54			0.100	
L3	17.25	17.5	17.75	0.679	0.689	0.699
L4	10.3	10.7	10.9	0.406	0.421	0.429
L5		5.28			0.208	
L6		2.38			0.094	
L7	2.65		2.9	0.104		0.114
S	1.9		2.6	0.075		0.102
S1	1.9		2.6	0.075		0.102
Dia. 1	3.65		3.85	0.144		0.152

MULTIHTBL



PMMULTIHTEPS

Information furnished is believed to be accurate and reliable. However, SGS-THOMSON Microelectronics assumes no responsibility for the consequences of use of such information nor for any infringement of patents or other rights of third parties which may result from its use. No license is granted by implication or otherwise under any patent or patent rights of SGS-THOMSON Microelectronics. Specifications mentioned in this publication are subject to change without notice. This publication supersedes and replaces all information previously supplied. SGS-THOMSON Microelectronics products are not authorized for use as critical components in life support devices or systems without express written approval of SGS-THOMSON Microelectronics.

© 1994 SGS-THOMSON Microelectronics - All Rights Reserved
MULTIWATT® is a Registered Trademark of SGS-THOMSON Microelectronics

SGS-THOMSON Microelectronics GROUP OF COMPANIES
Australia - Brazil - France - Germany - Hong Kong - Italy - Japan - Korea - Malaysia - Malta - Morocco - The Netherlands - Singapore -
Spain - Sweden - Switzerland - Taiwan - Thailand - United Kingdom - U.S.A.