

RGB MATRIX PREAMPLIFIER

The TDA2530 is an integrated RGB matrix preamplifier for colour television receivers, incorporating a matrix preamplifier for RGB cathode drive of the picture tube with clamping circuits. The three channels have the same layout to ensure identical frequency behaviour.

This integrated circuit has been designed to be driven from the TDA2522 synchronous demodulator and oscillator IC.

QUICK REFERENCE DATA

Supply voltage	V_{9-16}	typ.	12 V
Operating ambient temperature range	T_{amb}		-20 to +60 °C
Luminance input resistance	R_{1-16}	>	100 k Ω
Input current of colour difference inputs	I_2, I_4, I_6	typ.	2 μ A
during clamping	I_2, I_4, I_6		-0, 2 to +0, 2 mA
Clamping pulse input current	$-I_8$	<	20 μ A
Gain of RGB preamplifiers	G	typ.	0 dB
Gain d. c. adjustment range	ΔG	typ.	± 3 dB
Gain of error amplifier (conductance)		typ.	20 mA/V
Input current of feedback inputs	I_{11}, I_{13}, I_{15}	typ.	2 μ A
Output current swing	I_{10}, I_{12}, I_{14}		-4, 4 to +4, 4 mA

PACKAGE OUTLINES

TDA2530 : 16-lead DIL; plastic (SOT-38).

TDA2530Q : 16-lead QIL; plastic (SOT-58).



BLOCK DIAGRAM

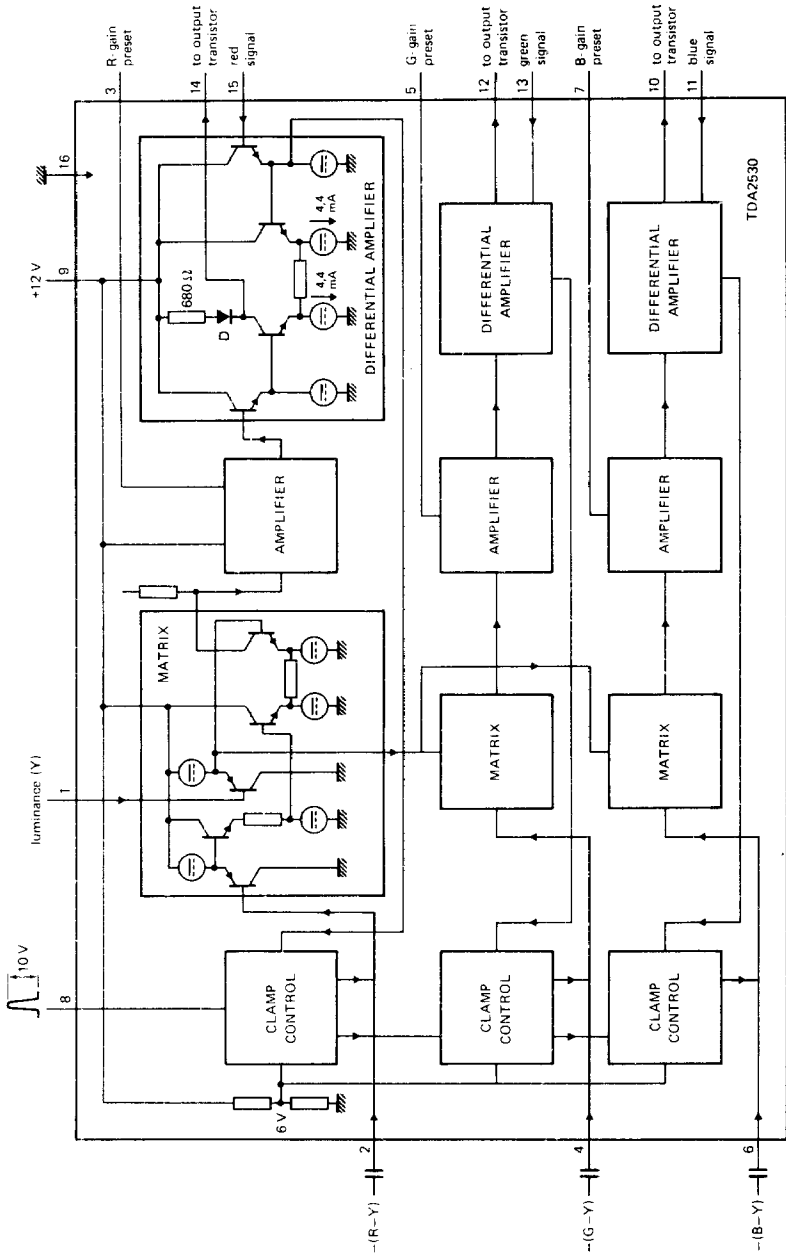

7275189

RATINGS Limiting values in accordance with the Absolute Maximum System (IEC134)

Voltages

Supply voltage (pin 9)	V_P (V ₉₋₁₆) max.	15 V
Pin 1	V_{1-16}	0 to V_P
Pins 3, 5 and 7	$V_{3;5;7-16}$	0 to V_P
Pins 2, 4 and 6	$V_{2;4;6-16}$	0 to V_P
Pin 8	V_{8-16} max.	V_P
Pin 10	V_{10-16}	V_{11-16} to $V_P + 3$ V
Pin 12	V_{12-16}	V_{13-16} to $V_P + 3$ V
Pin 14	V_{14-16}	V_{15-16} to $V_P + 3$ V
Pins 11, 13 and 15	$V_{11;13;15-16}$	0,3 V_P to V_P

Current

Pin 8	$-I_8$	max.	1 mA
-------	--------	------	------

Power dissipation

Total power dissipation	P_{tot}	max.	1 W
-------------------------	-----------	------	-----

Temperatures

Storage temperature	T_{stg}	-20 to +125 °C
Operating ambient temperature	T_{amb}	-20 to +60 °C

CHARACTERISTICS at $V_P = 12$ V; $V_{1-16} = 1,5$ V; $T_{amb} = 25$ °C; measured in circuit on page 5.

Current consumption	I_9	typ.	50 mA
---------------------	-------	------	-------

Luminance input

Black level	V_{1-16}	typ.	1,5 V
Black-to-white input voltage (peak-to-peak value)	$V_{1-16(p-p)}$	typ.	1,0 V
Input resistance	R_{1-16}	>	100 k Ω

Colour difference input

Input signals (peak-to-peak values) R-Y 1) G-Y 1) B-Y 1)	$V_{2-16(p-p)}$	typ.	1,4 V
	$V_{4-16(p-p)}$	typ.	0,82 V
	$V_{6-16(p-p)}$	typ.	1,78 V

Input currents (source resistance 300 Ω max.)	I_2, I_4, I_6	typ.	2 μ A
		<	4 μ A

Input currents during clamping	I_2, I_4, I_6	-0,2 to +0,2 mA
--------------------------------	-----------------	-----------------

1) This prescribed order is not mandatory, as all three channels are identical.

CHARACTERISTICS (continued)

Clamp pulse input for d.c. feedback

Input voltage for clamping: on level	V_{8-16}		6, 5 to 12	V
off level	V_{8-16}		0 to 5, 5	V ¹⁾
Input current for clamping: on level	I_8	<	1	μ A
off level	$-I_8$	<	20	μ A

Feedback input

D.C. level during clamping	$V_{11;13;15-16}$	typ.	0, 5	V _P
----------------------------	-------------------	------	------	----------------

Gain adjustment for colour drive

Adjustment voltage range	$V_{3;5;7-16}$		0 to 10	V
Adjustment voltage for nominal gain	$V_{3;5;7-16}$	typ.	5	V
Nominal gain between colour difference inputs, luminance input and colour feedback inputs (pins 11, 13 and 15)	G	typ.	0	dB ²⁾
Adjustment range of nominal gain at $\Delta V_{3;5;7-16} = \pm 5$ V	ΔG	>	± 3	dB

Differential amplifier

Input current of feedback inputs	I_{11}, I_{13}, I_{15}	typ.	2	μ A
Gain of error amplifier (conductance)		typ.	20	mA/V
Output current swing	I_{10}, I_{12}, I_{14}		-4, 4 to +4, 4	mA
Integrated load resistance	$R_{10;12;14-9}$	typ.	680	Ω ³⁾
Output bias voltage (see application information)	$V_{10;12;14-16}$	typ.	8	V ³⁾

APPLICATION INFORMATION (see circuit on page 5)

Clamping level (V_{cl}) of video output stages, with set clamping level potentiometers in their mid-positions:

$$V_{cl} = V_P \left(1 + \frac{R_1}{R_2} - \frac{R_1}{R_3} \right)$$

$$\text{Gain of video output stages: } G = 1 + \frac{R_1}{R_2} + \frac{R_1}{R_3} + \frac{R_1}{R_4}$$

1) Switching from clamping on to off occurs at about 6 V.

2) Error signal is assumed to be negligible.

3) The fact that the load resistors have series diodes (D; see block diagram on page 2), means that the resistors can be ignored when $V_{10;12;14} \geq V_P$. In that case, external load resistors must be chosen such that the nominal current will be 4, 4 mA.

APPLICATION INFORMATION

