

BI-DIRECTIONAL MOTOR DRIVER WITH BRAKE FUNCTION

DESCRIPTION

The M54544L is a semiconductor IC capable of directly driving a smallsize bi-directional motor for forward/reverse rotation.

FEATURES

- Wide operating voltage range ($V_{cc} = 4V$ to $16V$)
- Direct drive capability by TTL, PMOS and CMOS IC outputs
- Low output saturation voltage (large voltage across motor)
- Built-in clamp diode
- Large output current drive (I_o (max) = $\pm 1.2A$)
- With brake function

APPLICATION

Commercial-use equipment, audio such as tape recorder or radio cassette recorder, and VCR.

FUNCTIONAL DESCRIPTION

The M54544L is an IC for driving a smallsize bi-directional motor for forward/reverse rotation. When both of inputs 1 and 2 are "L", outputs 1 and 2 are "OFF". When input 1 is "H" and input 2 is "L", output 1 is "H" and output 2 is "L" (forward rotation). When input 1 is "L" and input 2 is "H", output 1 is "L" and output 2 is "H" (reverse rotation). When both of inputs 1 and 2 are "H", both of outputs 1 and 2 are "L" (braking).

The IC is provided with a control circuit power supply (V_{cc}) and an output power supply (V_{cc}') independently. The motor rotation speed can be changed by operating V_{cc} and V_{cc}' from a separate supply and varying the voltage of V_{cc} or V_{cc}' .

No current counter-flows from V_{cc} pin to V_{cc}' pin even if the motor resistance is high (small output current: several tens of mA at a light load) and V_{cc} is greater than V_{cc}' .

PIN CONFIGURATION (TOP VIEW)

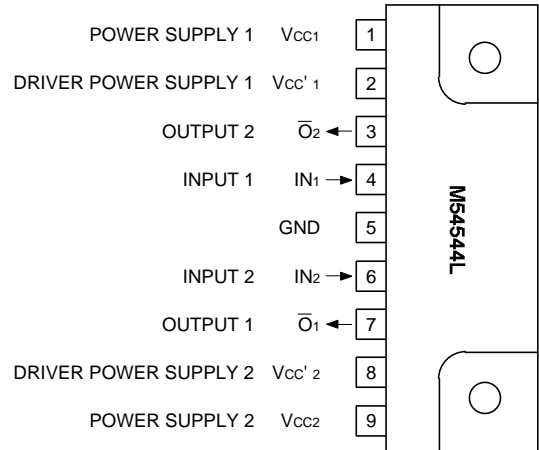

Outline 9P9

LOGIC TRUTH TABLE

INPUT		OUTPUT		NOTE
IN1	IN2	\bar{O}_1	\bar{O}_2	
L	L	"OFF" state	"OFF" state	Open
H	L	H	L	ex.Forward
L	H	L	H	ex.Reverse
H	H	L	L	Braking

BLOCK DIAGRAM

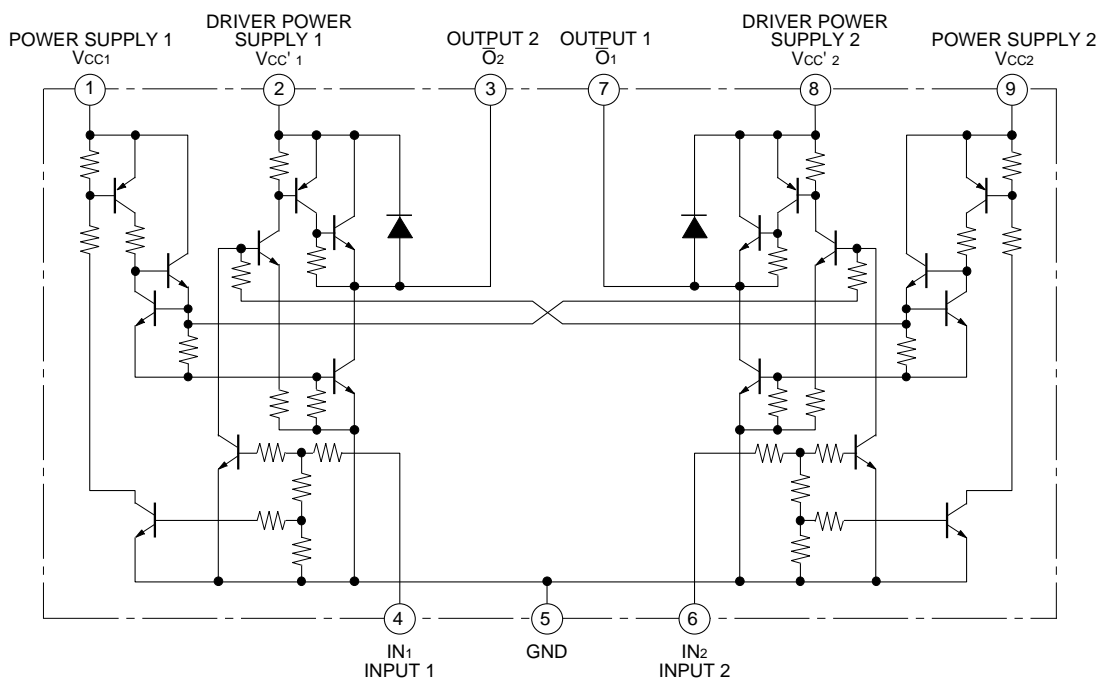

BI-DIRECTIONAL MOTOR DRIVER WITH BRAKE FUNCTION

ABSOLUTE MAXIMUM RATINGS (Ta=25°C, unless otherwise noted)

Symbol	Parameter	Conditions	Ratings	Unit
Vcc (1)	Supply voltage (1)		-0.5 to +16	V
Vcc (2)	Supply voltage (2)	With an external heat sink (3000mm ² ×1.5mm)	-0.5 to +20	V
Vcc'	Driver supply voltage		-0.5 to +16	V
Vi	Input voltage		0 to Vcc	V
Vo	Output voltage		-0.5 to Vcc'+2.5	V
Io (max)	Peak output current	top=10ms : Repetitive cycle 0.2Hz max	±1.2	A
Io (1)	Continuous output current (1)		±330	mA
Io (2)	Continuous output current (2)	With an external heat sink (3000mm ² ×1.5mm)	±600	mA
Pd	Power dissipation	Ta=75°C	1.15	W
Topr	Operating temperature		-10 to +75	°C
Tstg	Storage temperature		-55 to +125	°C

RECOMMENDED OPERATING CONDITIONS (Ta=25°C, unless otherwise noted)

Symbol	Parameter	Test conditions	Limits			Unit
			Min.	Typ.	Max.	
Vcc	Supply voltage		4	12	15	V
Io	Continuous output current				±300	mA
VIH	"H" Input voltage		2		Vcc	V
VIL	"L" Input voltage		0		0.4	V
tB	Motor braking interval		10	100		ms

ELECTRICAL CHARACTERISTICS (Ta=25°C, unless otherwise noted)

Symbol	Parameter	Test conditions		Limits			Unit	
				Min.	Typ.	Max.		
Io (leak)	Output leak current	Vcc=Vcc'=20V Vi1=Vi2=0V	Vo=20V			100	µA	
			Vo=0V			-100		
VOH (1)	"H" Output saturation voltage (1)	Vcc=Vcc'=12V	Vi1=2V Vi2=0V	IoH (1)=-300mA	10.8	11.2	V	
				IoH (1)=-500mA	10.7	11.1		
VOH (2)	"H" Output saturation voltage (2)	Vcc=Vcc'=12V	Vi1=0V Vi2=2V	IoH (2)=-300mA	10.8	11.2	V	
				IoH (2)=-500mA	10.7	11.1		
VOL (1)	"L" Output saturation voltage (1)	Vcc=Vcc'=12V	Vi1=0V Vi2=2V	IoL (1)=300mA		0.18	0.5	V
				IoL (1)=500mA		0.3	0.65	
			Vi1=Vi2=2V			0.3	0.65	
VOL (2)	"L" Output saturation voltage (2)	Vcc=Vcc'=12V	Vi1=2V Vi2=0V	IoL (2)=300mA		0.18	0.5	V
				IoL (2)=500mA		0.3	0.65	
			Vi1=Vi2=2V				0.3	
IIH (1)	"H" Input current (1)	Vcc=Vcc'=12V, Vi1=2V, Vi2=0V		70		200	µA	
IIH (2)	"H" Input current (2)	Vcc=Vcc'=12V, Vi1=0V, Vi2=2V		70		200	µA	
Icc	Supply current	Vcc=Vcc' =16V Output open	Vi1=2V, Vi2=0V			30	mA	
			Vi1=0V, Vi2=2V					
			Vi1=Vi2=2V			60		
			Vi1=Vi2=0V		0			

BI-DIRECTIONAL MOTOR DRIVER WITH BRAKE FUNCTION

TYPICAL CHARACTERISTICS

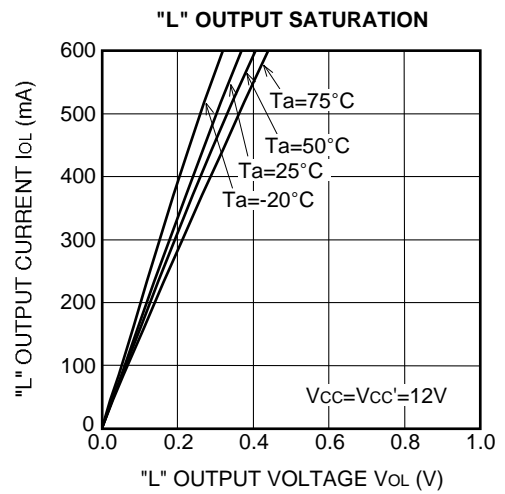
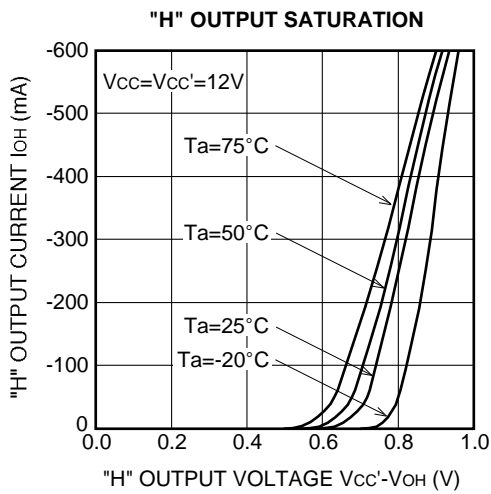
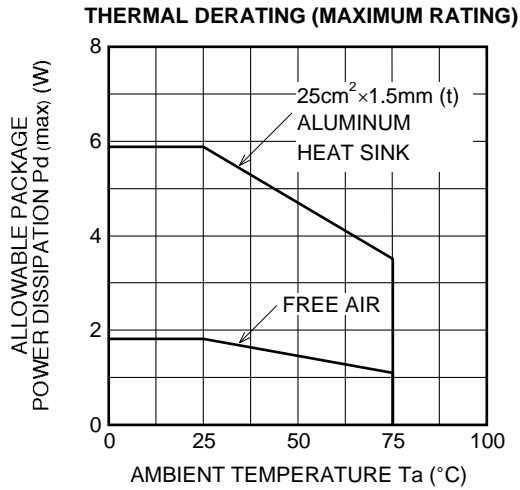

BI-DIRECTIONAL MOTOR DRIVER WITH BRAKE FUNCTION

PRECAUTIONS FOR APPLICATION

(1) Through current of 2 to 4A flows from the power supply to GND for 2 to 4 μ s when switching a mode. Remember to connect a capacitor of 10 to 100 μ F between the output power supply and the GND.

If the motor has a large counter electromotive force at a braking time, etc., the internal parasitic Di may malfunction.

If fly-back current of 1A or more flows, put a shottkey Di between the output and the GND.

Remember that the IC has an about 10 μ s delay in output switching for high-speed applications such as PWM.

(2) As far as motor control and driver IC's are concerned, some possibilities are considered for these IC's to cause such unexpected cases as fire or smoke if they are used beyond its ratings in datasheet or used, even transiently, under the overload conditions. So your action will be highly appreciated to fully look into the rating limits and the using conditions before you use these IC's.

And if these IC's are to be used under the conditions out of our specifications, please never fail to give us a contact as to under what conditions they are used.

APPLICATION EXAMPLES

1) Motor speed control by Vcc and Vcc'

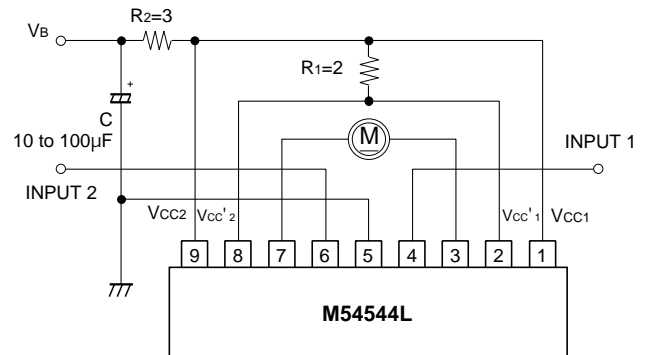

2) Motor speed control by the Vcc'

