

M54544AL

Bi-DIRECTIONAL MOTOR DRIVER WITH BRAKE FUNCTION AND THERMAL SHUT DOWN FUNCTION

DESCRIPTION

The M54544AL is a semiconductor IC capable of directly driving a smallsize bi-directional motor for forward/reverse rotation.

FEATURES

- Wide operating voltage range ($V_{cc} = 4V$ to $16V$)
- Direct drive capability by TTL, PMOS and CMOS IC outputs
- Low output saturation voltage (large voltage across motor)
- Built-in clamp diode
- Large output current drive (I_o (max) = $\pm 1.5A$)
- With brake function
- Built-in thermal shut-down protector circuit

APPLICATION

Commercial-use equipment, audio such as tape recorder or radio cassette recorder, and VCR.

FUNCTIONAL DESCRIPTION

The M54544AL is an IC for driving a smallsize bi-directional motor for forward/reverse rotation. When both of inputs 1 and 2 are "L", outputs 1 and 2 are "OFF". When input 1 is "H" and input 2 is "L", output 1 is "H" and output 2 is "L" (forward rotation). When input 1 is "L" and input 2 is "H", output 1 is "L" and output 2 is "H" (reverse rotation). When both of inputs 1 and 2 are "H", both of outputs 1 and 2 are "L" (braking).

The IC is provided with a control circuit power supply (V_{cc}) and an output power supply (V_{cc}') independently. The motor rotation speed can be changed by operating V_{cc} and V_{cc}' from a separate supply and varying the voltage of V_{cc} or V_{cc}' .

No current counter-flows from V_{cc} pin to V_{cc}' pin even if the motor resistance is high (small output current: several tens of mA at a light load) and V_{cc} is greater than V_{cc}' .

PIN CONFIGURATION (TOP VIEW)

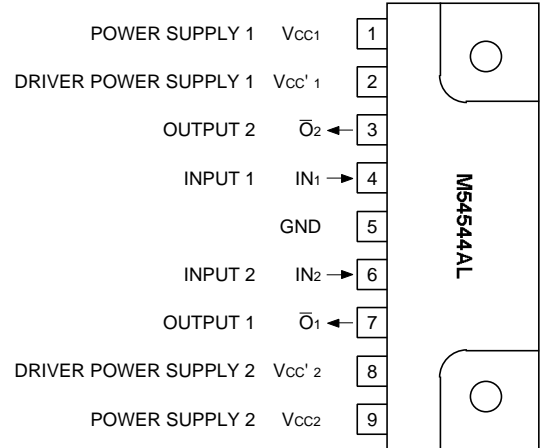

Outline 9P9

The IC is also provided with a built-in thermal protector circuit to protect it from thermal destruction in case of abnormal condition such as motor blocking.

LOGIC TRUTH TABLE

INPUT		OUTPUT		NOTE
IN ₁	IN ₂	\bar{O}_1	\bar{O}_2	
L	L	"OFF" state	"OFF" state	Open
H	L	H	L	ex.Forward (→)
L	H	L	H	ex.Reverse (←)
H	H	L	L	Braking

BLOCK DIAGRAM

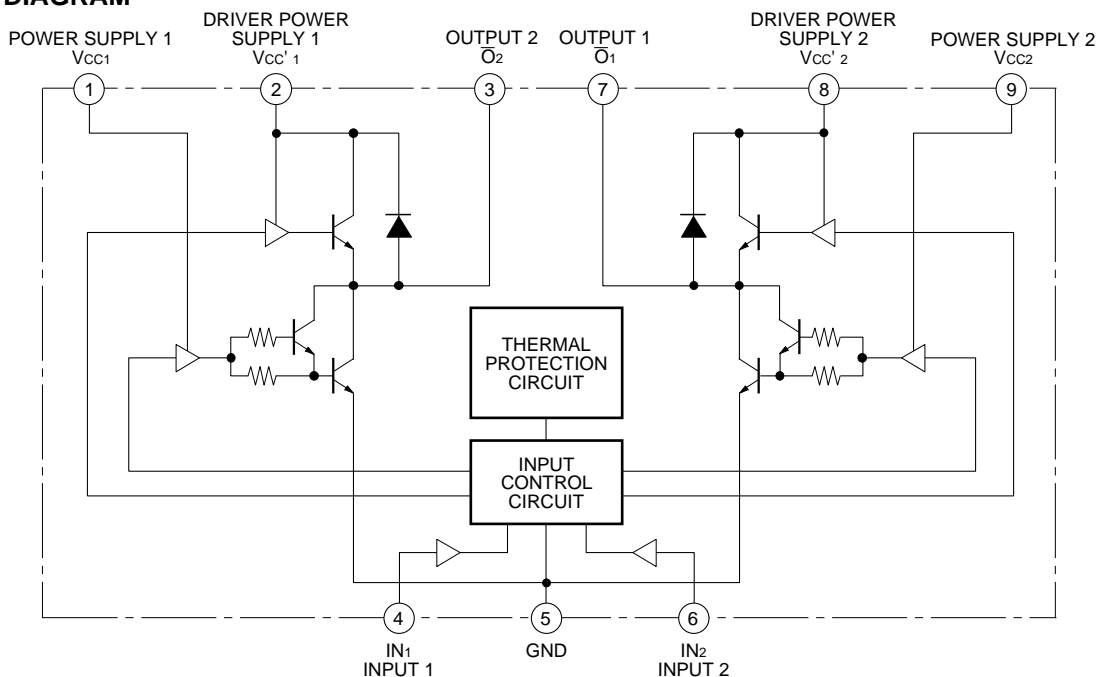

**Bi-DIRECTIONAL MOTOR DRIVER
WITH BRAKE FUNCTION AND THERMAL SHUT DOWN FUNCTION**

ABSOLUTE MAXIMUM RATINGS (Ta=25°C, unless otherwise noted)

Symbol	Parameter	Conditions	Ratings	Unit
V _{CC (1)}	Supply voltage (1)		-0.5 to +16	V
V _{CC (2)}	Supply voltage (2)	With an external heat sink (3000mm ² ×1.5mm)	-0.5 to +20	V
V _{CC'}	Driver supply voltage		-0.5 to +16	V
V _I	Input voltage		0 to V _{CC}	V
V _O	Output voltage		-0.5 to V _{CC'} +2.5	V
I _{O (max)}	Peak output current	top=10ms : Repetitive cycle 0.2Hz max	±1.5	A
I _{O (1)}	Continuous output current (1)		±330	mA
I _{O (2)}	Continuous output current (2)	With an external heat sink (3000mm ² ×1.5mm)	±600	mA
P _d	Power dissipation	Ta=75°C	1.15	W
T _{opr}	Operating temperature		-10 to +75	°C
T _{stg}	Storage temperature		-55 to +125	°C

RECOMMENDED OPERATING CONDITIONS (Ta=25°C, unless otherwise noted)

Symbol	Parameter	Test conditions	Limits			Unit
			Min.	Typ.	Max.	
V _{CC}	Supply voltage		4	12	15	V
I _O	Continuous output current				±300	mA
V _{IH}	"H" Input voltage		2		V _{CC}	V
V _{IL}	"L" Input voltage		0		0.4	V
t _B	Motor braking interval		10	100		ms
T _{j (shut)}	Thermal shutdown temperature	V _{CC} ≥7V		150		°C

ELECTRICAL CHARACTERISTICS (Ta=25°C, unless otherwise noted)

Symbol	Parameter	Test conditions		Limits			Unit
				Min.	Typ.	Max.	
I _{O (leak)}	Output leak current	V _{CC} =V _{CC'} =20V V _{I1} =V _{I2} =0V	V _O =20V V _O =0V			100 -100	μA
V _{OH (1)}	"H" Output saturation voltage (1)	V _{CC} =V _{CC'} =12V	V _{I1} =2V V _{I2} =0V	I _{OH (1)} =-200mA I _{OH (1)} =-500mA	10.8 10.7	11.2 11.1	V
V _{OH (2)}	"H" Output saturation voltage (2)	V _{CC} =V _{CC'} =12V	V _{I1} =0V V _{I2} =2V	I _{OH (2)} =-200mA I _{OH (2)} =-500mA	10.8 10.7	11.2 11.1	V
V _{OL (1)}	"L" Output saturation voltage (1)	V _{CC} =V _{CC'} =12V	V _{I1} =0V V _{I2} =2V V _{I1} =V _{I2} =2V	I _{OL (1)} =200mA I _{OL (1)} =500mA		0.2 0.95 1.35	V
V _{OL (2)}	"L" Output saturation voltage (2)	V _{CC} =V _{CC'} =12V	V _{I1} =2V V _{I2} =0V V _{I1} =V _{I2} =2V	I _{OL (2)} =200mA I _{OL (2)} =500mA		0.2 0.95 1.35	V
I _{IH (1)}	"H" Input current (1)	V _{CC} =V _{CC'} =12V, V _{I1} =2V, V _{I2} =0V			50	120	μA
I _{IH (2)}	"H" Input current (2)	V _{CC} =V _{CC'} =12V, V _{I1} =0V, V _{I2} =2V			50	120	μA
I _{CC}	Supply current	V _{CC} =V _{CC'} =16V Output open	V _{I1} =2V, V _{I2} =0V V _{I1} =0V, V _{I2} =2V V _{I1} =V _{I2} =2V V _{I1} =V _{I2} =0V			15 20 4	mA

TYPICAL CHARACTERISTICS

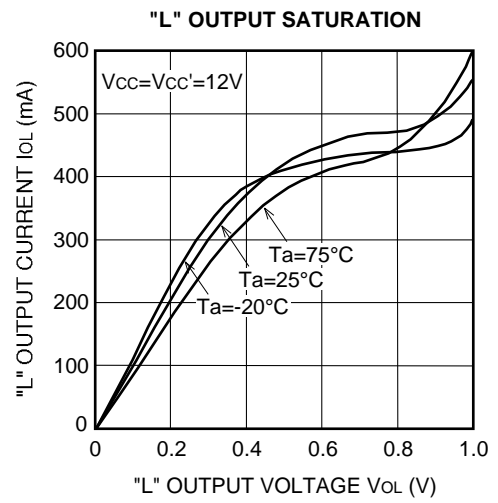
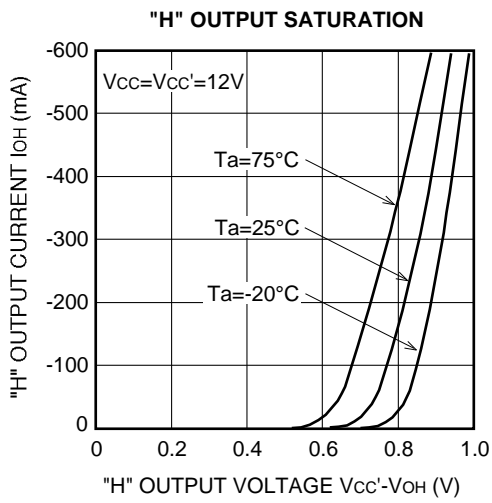
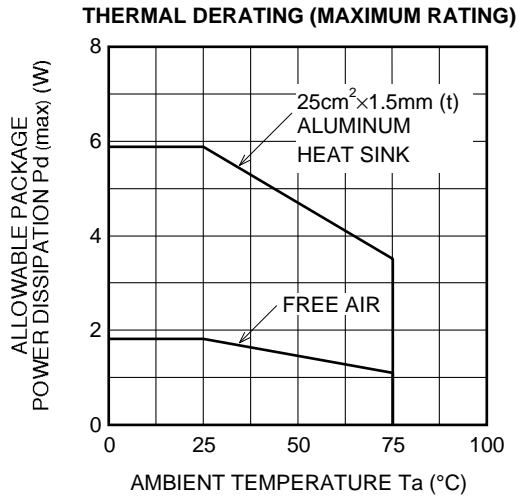

M54544AL

Bi-DIRECTIONAL MOTOR DRIVER WITH BRAKE FUNCTION AND THERMAL SHUT DOWN FUNCTION

PRECAUTIONS FOR APPLICATION

(1) The thermal protection of the IC may not work depending on an abnormal condition (such as oscillation, low supply voltage or output short). When using the function, check its operation in the actual using state.

If the motor has a large counter electromotive force at a braking time, etc., the internal parasitic Di may malfunction.

If fly-back current of 1A or more flows, put a shottkey Di between the output and the GND.

Remember that the IC has an about 10 μ s delay in output switching for high-speed applications such as PWM.

(2) As far as motor control and driver IC's are concerned, some possibilities are considered for these IC's to cause such unexpected cases as fire or smoke if they are used beyond its ratings in datasheet or used, even transiently, under the overload conditions. So your action will be highly appreciated to fully look into the rating limits and the using conditions before you use these IC's.

And if these IC's are to be used under the conditions out of our specifications, please never fail to give us a contact as to under what conditions they are used.

APPLICATION EXAMPLES

1) Motor speed control by Vcc and Vcc'

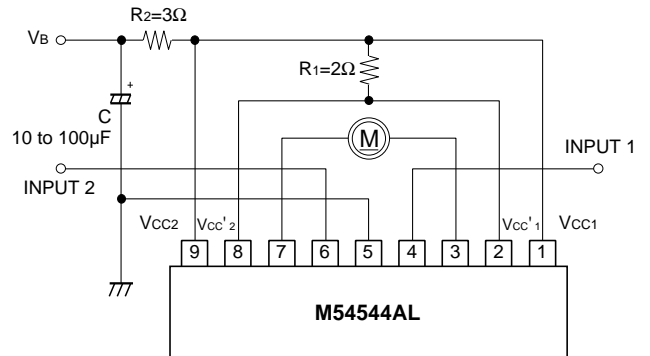

2) Motor speed control by the Vcc'

