

HA11221

B/W TV Picture IF Amplifier

FUNCTIONS

- Picture IF Amplifier
- Video Detector
- AGC Detector
- Noise Canceller
- Forward AGC
- Sync. Separator

FEATURES

- Particularly useful in B/W TV's with bipolar tuner.
- Low external parts count.
- Designed to operate at Vcc down to 6.5V.
- Video output level stabilized, independent of supply voltage and ambient temperature.

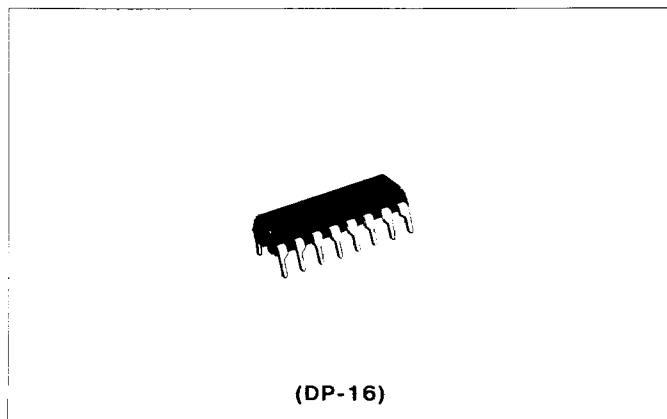

BLOCK DIAGRAM

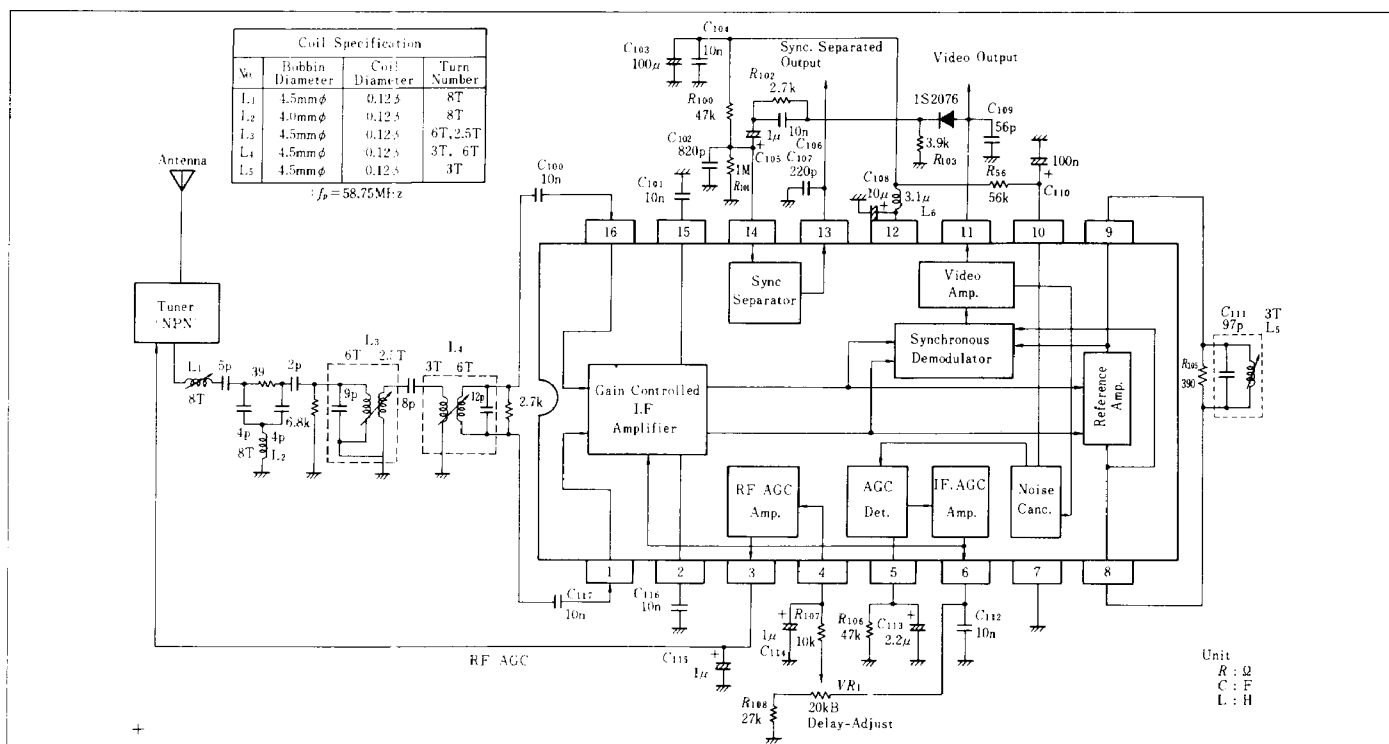

ABSOLUTE MAXIMUM RATINGS ($T_a = 25^\circ\text{C}$ unless otherwise specified)

Item	Symbol	Ratings	Unit
Supply Voltage	V_{CC}	15*	V
Max. Input Voltage	$V_{in\ max}$	3	Vp-p
Video Output Current	I_{O1}	3	mA
Max. Applicable Voltage	3, 4 pin	V_{CC}	V
	6 pin	6.3	V
Power Dissipation	P_T	850**	mW
Operating Temperature	T_{opr}	-20 to +65	$^\circ\text{C}$
Storage Temperature	T_{stg}	-55 to +150	$^\circ\text{C}$

* Value at $t \leq 60\text{sec min.}$

** Value at $T_a = 60^\circ\text{C}$

■ ELECTRICAL CHARACTERISTICS ($V_{cc}=11V$, $f_c=58.75MHz$, $T_a=25^\circ C$)

Item	Symbol	Test Conditions	min.	typ.	max.	Unit
Input Sensitivity	$V_{i(sens)}$	$m=87.5\%$	37	42	47	$dB\mu$
Video Output Voltage	V_{out}	$V_{in}=10mVrms$, $m=87.5\%$	0.95	1.21	1.47	Vp-p
Min. RF AGC Voltage	V_3_{min}	$V_{in}=0$	1.6	1.8	2.0	V
Max. RF AGC Voltage	V_3_{max}	4 pin \rightarrow GND	6.0	7.0	8.0	V
Sync. Separated Output	V_{13}	Vertical Sync. Pulse	9.0	10.3	—	V
Video Band Width	G_W	$V_{out}(f=6MHz)/V_{out}(f=100kHz)$	-13	-6	-1	dB
Sync. Tip Voltage	V_{sync}	$V_{in}=10mVrms$	4.64	5.14	5.64	V
Supply Current	I_{cc}	$V_{in}=0$	33	41	53	mA

VIDEO OUTPUT VOLTAGE, SYNC. TIP VOLTAGE AND SYNC. SEPARATED OUTPUT VS. SUPPLY VOLTAGE

MAXIMUM INPUT CHARACTERISTICS

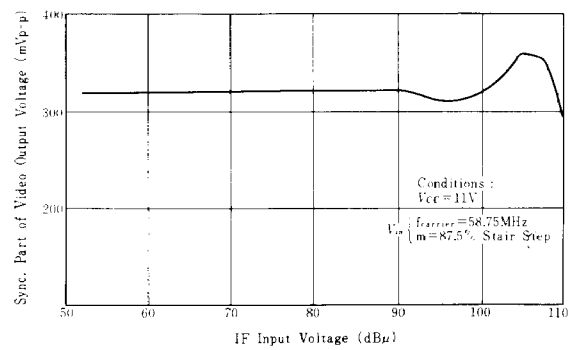
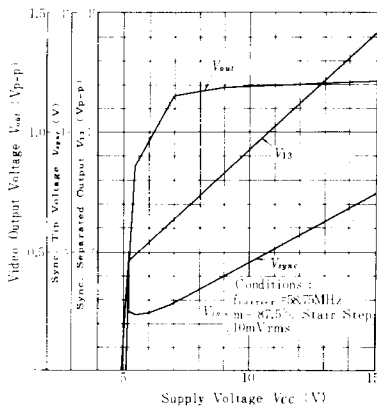

INPUT SENSITIVITY CHARACTERISTICS

VIDEO OUTPUT VOLTAGE VS. FREQUENCY

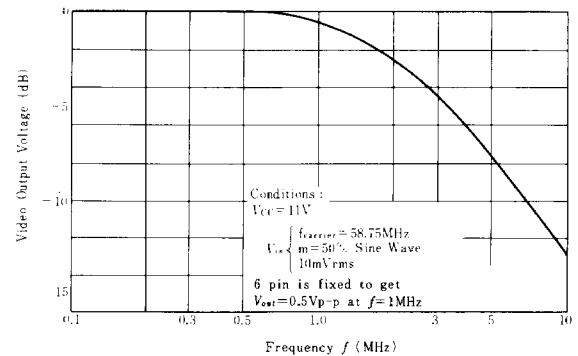
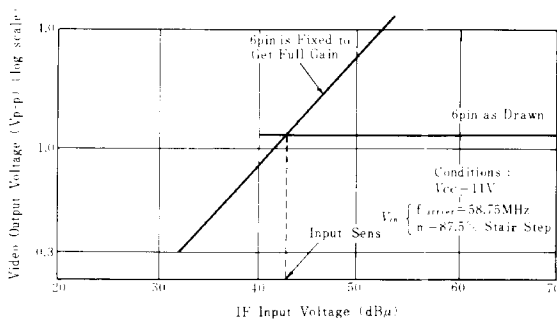

INPUT-OUTPUT CHARACTERISTICS OF RF AGC CIRCUIT

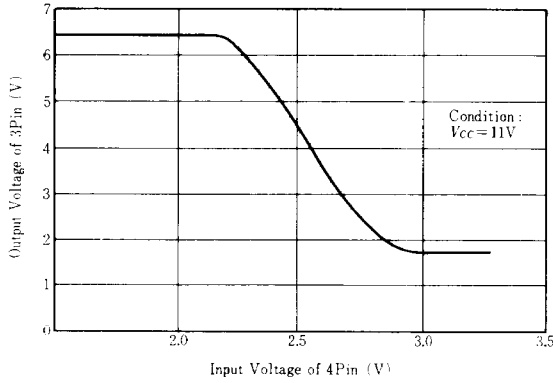

LINEARITY

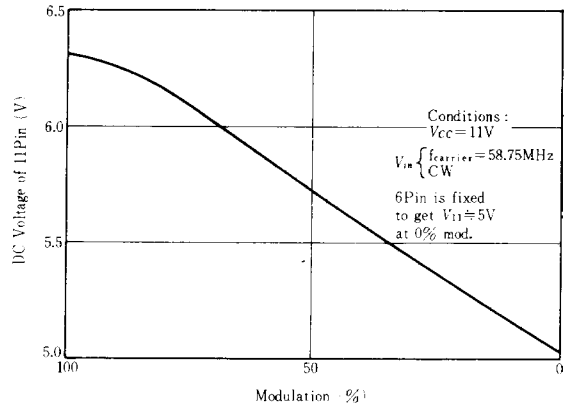

AGC CUT IN LEVEL VS. TEMPERATURE

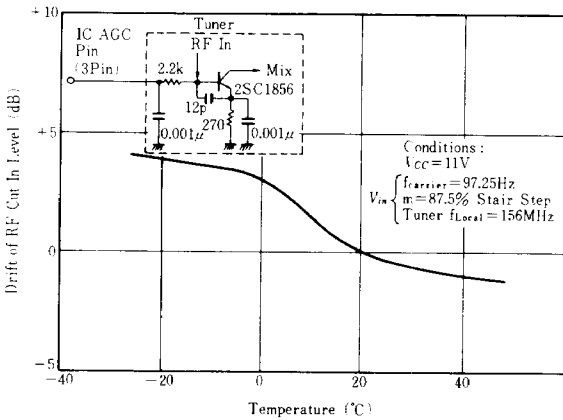

MIN. RF AGC VOLTAGE VS. TEMPERATURE

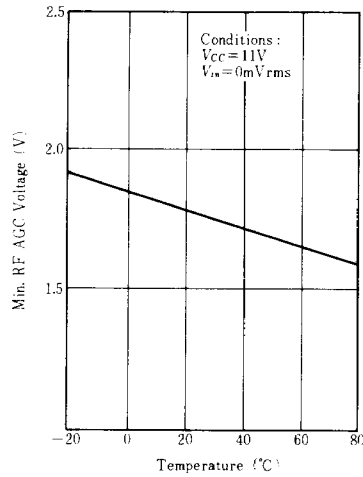

SYNC. SEPARATED OUTPUT VS. TEMPERATURE

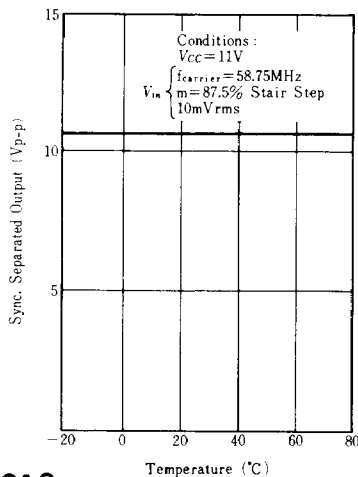

VIDEO OUTPUT VOLTAGE VS. TEMPERATURE

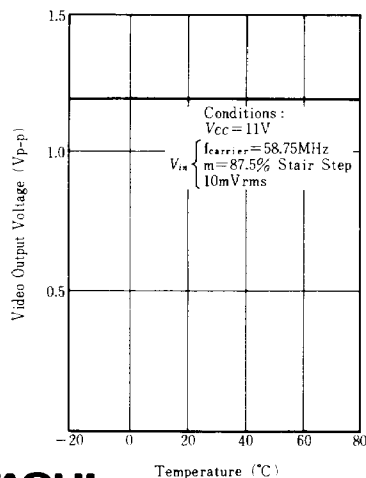

INPUT SENSITIVITY VS. TEMPERATURE

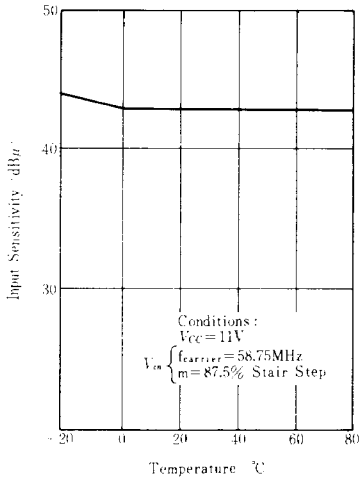

INPUT SENSITIVITY VS. SUPPLY VOLTAGE

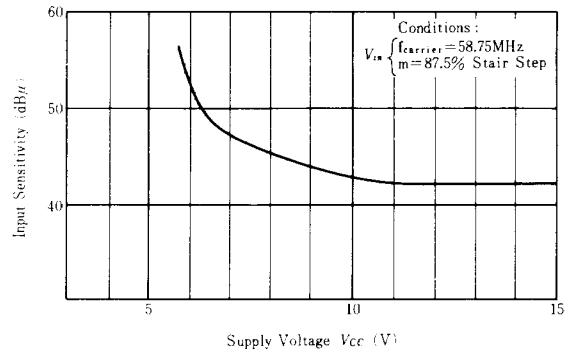

MIN. RF AGC VOLTAGE VS. SUPPLY VOLTAGE

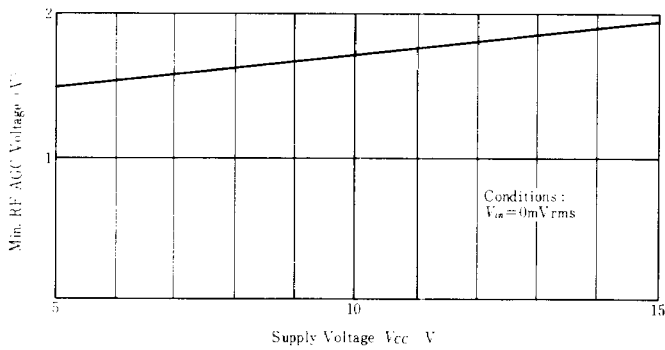

AGC CUT IN LEVEL VS. SUPPLY VOLTAGE

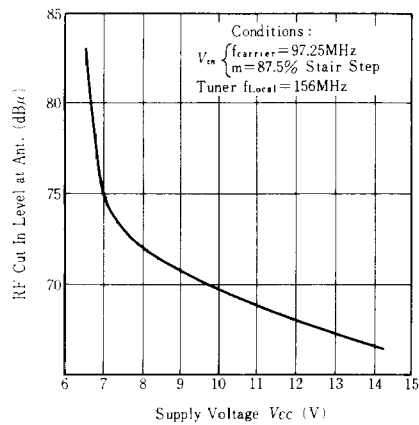

VIDEO OUTPUT VOLTAGE VS. LOCAL OSC. FREQUENCY

