

M52057FP

VHS SYSTEM VCR CHROMA SIGNAL PROCESSOR

DESCRIPTION

The M52057FP is a semiconductor integrated circuit with all the recording and playback chroma signal processing functions for VHS system VCRs.

It includes burst up, burst down with dubbing switch, main balanced modulator, sub balanced modulator, burst ACC, chroma ACC, APC, REC AFC, chroma killer, VCXO, 320fh VCO, quadphase 40fh generator, burst gate pulse generator (3 types), side lock detector, and DP compensation for PAL.

FEATURES

- Suitable for NTSC, PAL and modified SECAM.
- CHROMA ACC improves chroma S/N by expanding the recording level of the low saturation chroma.
- When recording, comb filter can be used for Y/C separation by setting pin 24 to "L".
- When dubbing, setting pin 23 to "L" changes the amount of burst down from 4.6dB to 6.0dB so chroma saturation doesn't decrease so much. (In NTSC SP and EP)
- By removing the comb filter from the APC loop, PM S/N is improved by 2dB. (In NTSC SP, PAL SP)
- By increasing the APC loop gain in the vertical blanking period, the color missing on the upper side of the picture is improved. (In NTSC EP/LP and PAL LP)

APPLICATION

VHS MODE VCR

RECOMMENDED OPERATING CONDITION

Supply voltage range 4.5~5.5V
 Rated supply voltage 5.0V

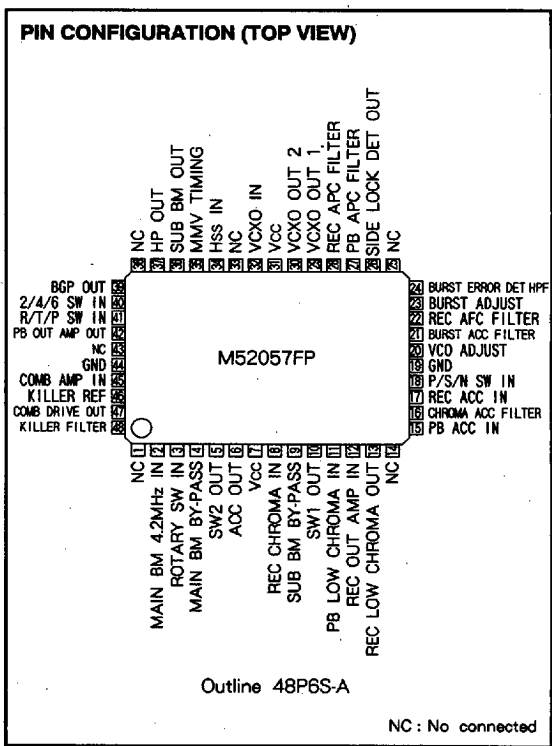

VHS SYSTEM VCR CHROMA SIGNAL PROCESSOR

BLOCK DIAGRAM

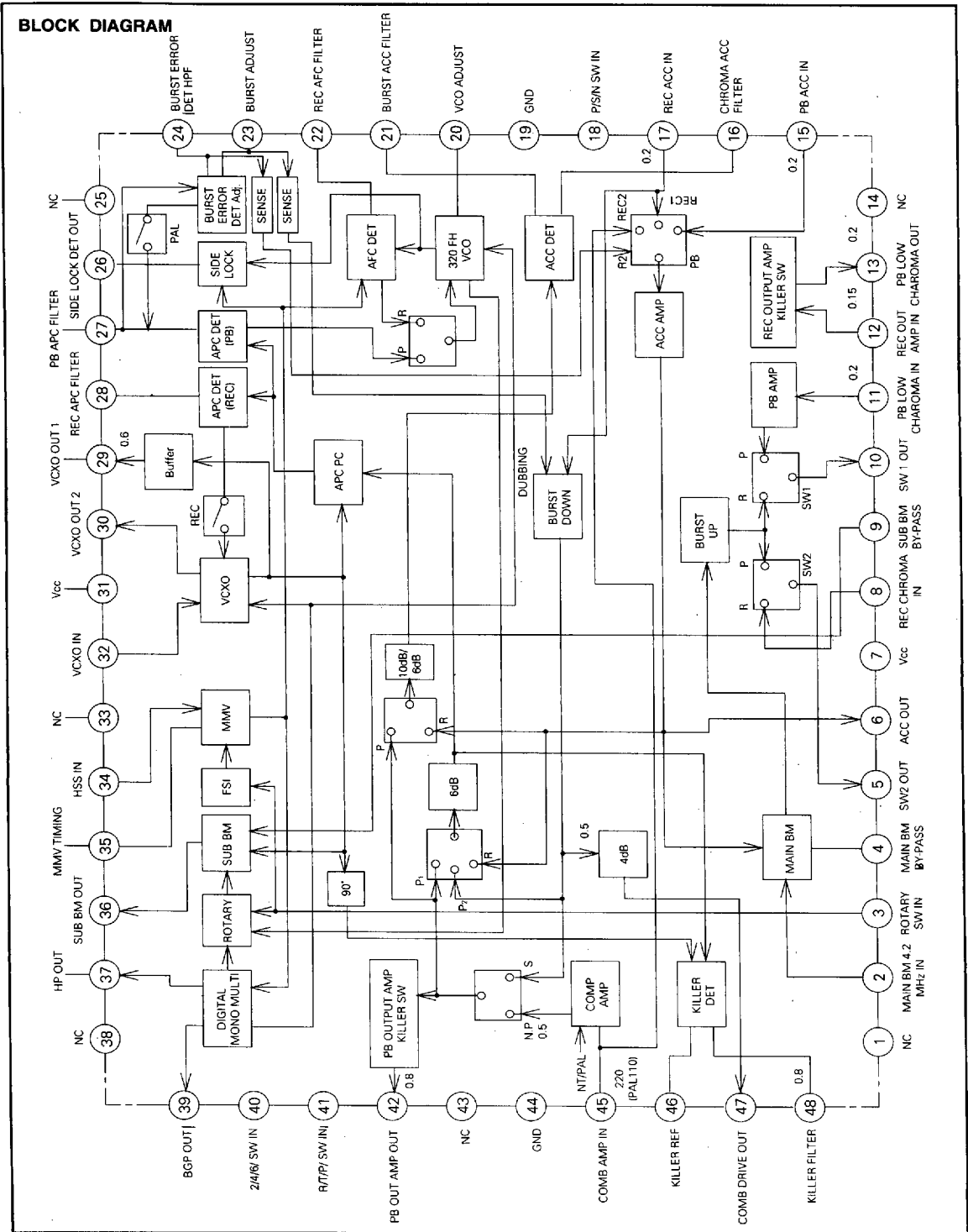

6249826 0022661 10T



VHS SYSTEM VCR CHROMA SIGNAL PROCESSOR

ABSOLUTE MAXIMUM RATINGS

Symbol	Parameter	Ratings	Unit
V _{cc}	Supply voltage	6	V
P _d	Power dissipation	1.0	W
T _{opr}	Operating temperature	-20~75	°C
T _{stg}	Storage temperature	-40~125	°C
K _θ	Thermal derating (T _a ≥25°C)	10	mW/°C

ELECTRICAL CHARACTERISTICS (T_a = 25°C, V_{cc} = 5.0 V unless otherwise noted)

Symbol	Parameter	Test point	Test conditions	Limits			Unit
				Min.	Typ.	Max.	
I _{cc}	Circuit current	1	Measure currents flowing into pins ⑦ and ⑧.	52	65	78	mA
G _{PI}	PB Amp. gain	2	Input ① pin 630 kHz, 0.4 V _{p-p} sine wave. Measure ⑩ pin.	10	12	14	dB
G _{RO}	REC output Amp. gain	3	Input ⑫ pin 630 kHz, 0.25 V _{p-p} sine wave. Measure ⑬ pin.	2.8	3.8	4.8	dB
G _{RU}	Recording current increase at 4/6 H mode	3	Input ⑫ pin 630 kHz, 0.25 V _{p-p} sine wave. Put ⑩ pin 5 V in 6 H mode. Measure ⑬ pin.	1.0	1.5	2.0	dB
G _B	BURST DOWN4 dB Amp. gain	4	Input ⑰ pin 3.58 MHz, 0.2 V _{p-p} sine wave. Measure ⑱ pin.	10.4	12.4	14.4	dB
G _{BP}	BURST DOWNPB output Amp. gain	4	Input ⑰ pin 3.58 MHz, 0.2 V _{p-p} sine wave. Measure ⑱ pin.	12.2	14.2	16.2	dB
G _{CPN}	COMB Amp. PB output Amp. gain 1	5	Input ⑮ pin 3.58 MHz, 0.22 V _{p-p} sine wave. Switch ⑲ pin to 0 V setting NTSC. Measure ⑳ pin.	11.0	13.0	15.0	dB
G _{CPP}	COMB Amp. PB output Amp. gain 2	5	Input ⑮ pin 3.58 MHz, 0.11 V _{p-p} sine wave. Switch ⑲ pin to 2.5 V setting PAL. Measure ⑳ pin.	17.0	19.0	21.0	dB
ACC _R	REC ACC output amplitude	6	Input ③ pin chroma signal (burst 0.2 V _{p-p} , chroma 0.4 V _{p-p}). Input ④ pin 15.734 kHz SYNC. Measure ⑬ pin for chroma amplitude.	0.4	0.6	0.8	V _{p-p}
ACC _{R1}	REC ACC control range 1	6	Input ③ pin -18 dB of standard chroma signal. Input ④ pin SYNC signal. Measure ⑬ pin for chroma amplitude.	-3		0	dB
ACC _{R2}	REC ACC control range 2	6	Input ③ pin chroma +6 dB of standard chroma signal. Input ④ pin SYNC signal. Measure ⑬ pin for chroma amplitude.	0		3	dB
ACC _C	Chroma ACC increase	6	Input ③ pin chroma signal (burst 0.2 V _{p-p} , chroma 0 V _{p-p}). Input ④ pin SYNC signal. Measure ⑬ pin for burst amplitude.	2	3	4	dB
V _{RCOMB}	REC Y/C comb separation output amplitude	6	Input ⑮ pin standard chroma signal. Input ⑳ pin SYNC signal. Measure ⑬ pin for chroma amplitude.	0.4	0.6	0.8	V _{p-p}
ACC _P	PB ACC output amplitude	7	Input ① pin standard down-converted chroma signal (burst 0.1 V _{p-p} chroma 0.1 V _{p-p} 630kHz). Input ④ pin SYNC signal. Measure ⑱ pin for chroma amplitude.	0.64	0.75	0.86	V _{p-p}
ACC _{P1}	PB ACC control range 1	7	Input ① pin -18 dB of standard down-converted chroma signal. Input ④ pin SYNC signal. Measure ⑱ pin for chroma amplitude.	-3		0	dB
ACC _{P2}	PB ACC control range 2	7	Input ① pin +6 dB of standard down-converted chroma signal. Input ④ pin SYNC signal. Measure ⑱ pin for chroma amplitude.	0		3	dB

6249826 0022662 046



VHS SYSTEM VCR CHROMA SIGNAL PROCESSOR

ELECTRICAL CHARACTERISTICS (cont.)

Symbol	Parameter	Test point	Test conditions	Limits			Unit
				Min.	Typ.	Max.	
GMB	MAIN BM gain	8	Input ④ pin 3.58 MHz, 0.5 Vp-p sine wave. Supply ② pin with offset grounding the pin through an 18 k Ω resistor. Measure ⑤ pin.	5	6	7	dB
CLMB	MAIN BM carrier leak	8	Input ④ pin 630 kHz, 0.5 Vp-p sine wave. Input ② pin 4.21 MHz, 0.25 Vp-p sine wave. Measure ⑤ pin for 3.58 MHz and 4.21 MHz components.		-45	-38	dB
Gsb	SUB BM output amplitude	9	Measure ⑥ pin.	0.9	1.15	1.4	Vp-p
CLsb	SUB BM carrier leak	9	Measure ⑥ pin for 4.21 MHz and 3.58 MHz components.		-40	-34	dB
SPsb	SUB BM spurious	9	Measure ⑥ pin for 4.21 MHz and (3.58 + 0.63 \times 2) MHz components.		-40	-34	dB
BU	BURST UP quantity	10	Input ④ pin 630 kHz, 0.25 Vp-p sine wave. Input ② pin SYNC signal. Measure ⑩ pin for burst and chroma amplitude.	5	6	7	dB
BD	BURST DOWN quantity	11	Input ⑩ pin 3.58 MHz, 0.2 Vp-p sine wave. Input ② pin SYNC signal. Measure ⑪ pin for burst and chroma amplitude.	-5.4	-4.4	-3.4	dB
BDD	BURST DOWN quantity in dubbing	11	Input ⑩ pin 3.58 MHz, 0.2 Vp-p sine wave. Input ② pin SYNC signal. Connect 5 V to ② pin through a 51 k Ω resistor. Measure ⑪ pin for burst and chroma amplitude.	-7	-6	-5	dB
β VCOR	320 fh VCO β 1	12	Apply 3.1 V and then 3.5 V to ⑫ pin. Measure ⑬ pin.	0.8	1.3	1.8	kHz/mV
β VCOF	320 fh VCO β 2	12	Apply 3.1 V and then 3.5 V to ⑫ pin. Measure ⑭ pin.	1.25	1.6	1.7	kHz/mV
PULLAFC1	REC AFC pull-in range 1	13	Input ⑭ pin pulses (frequency variable). Measure ⑮ pin.	0.5	1.2		kHz
PULLAFC2	REC AFC pull-in range 2	13	Input ⑭ pin pulses (frequency variable). Measure ⑯ pin.		-1.2	-0.5	kHz
Vcxo	Vcxo output amplitude	14	Measure ⑰ pin.	0.5	0.6	0.7	Vp-p
Δ FvxO	Vcxo free running frequency difference	14	Input ⑰ pin SYNC signal. Measure ⑱ pin.	-150	0	150	Hz
β VcxO	Vcxo β	14	Apply 3.6 V and then 4.0 V to ⑱ pin. Measure ⑲ pin.	3	5	7	Hz/mV
μ APCR	REC APC DET μ	15	Input ⑰ pin 3.58 MHz, 0.1 Vp-p, ⑲ pin 3.58 MHz, 0.5 Vp-p. Both inputs are to be in phase. Input ⑲ pin SYNC signal. Measure ⑳ pin.	20	25	30	mV/deg
μ APCP	PB APC DET μ	16	Input ⑳ pin 3.58 MHz, 0.22 Vp-p, ⑲ pin 3.58 MHz, 0.5 Vp-p. Both inputs are to be in phase. Input ⑲ pin SYNC signal. Measure ㉑ pin.	200	280		mV/deg
PULLAPC1	REC APC pull-in range 1	17	Input ⑰ pin frequency variable 0.1 Vp-p. Input ⑲ pin SYNC signal. Measure ㉒ pin.	500	1000		Hz
PULLAPC2	REC APC pull in range 2	17	Input ⑰ pin frequency variable 0.1 Vp-p. Input ⑲ pin SYNC signal. Measure ㉓ pin.		-700	-500	Hz
THKILLR	REC color killer threshold	6	Input ⑳ pin chroma signal (input ATT). Input ⑲ pin SYNC signal. Measure ㉔ pin.	-41	-36	-31	dB
Δ THKILLR	REC color killer hysteresis	6	Input ⑳ pin chroma signal (input ATT). Input ⑲ pin SYNC signal. Measure ㉔ pin.	1	2	3	dB

VHS SYSTEM VCR CHROMA SIGNAL PROCESSOR

ELECTRICAL CHARACTERISTICS (cont.)

Symbol	Parameter	Test point	Test conditions	Limits			Unit
				Min.	Typ.	Max.	
THKILLP	PB color killer threshold	7	Input ① pin down-converted chroma signal (input ATT). Input ⑭ pin SYNC signal. Measure ⑬ pin.	-41	-36	-31	dB
ΔTHKILLP	PB color killer hysteresis	7	Input ① pin down-converted chroma signal (input ATT). Input ⑭ pin SYNC signal. Measure ⑬ pin.	1	2	3	dB
THBGPR	BGP N/W switchover threshold 1	6	Input ⑧ pin chroma signal (input ATT). Input ⑭ pin SYNC signal. Measure ⑰ pin.	-29	-24	-19	dB
THBGPP	BGP N/W switchover threshold 2	7	Input ① pin down-converted chroma signal (input ATT). Input ⑭ pin SYNC signal. Measure ⑰ pin.	-29	-24	-19	dB
PWMMV	MMV pulse width	18	Input ⑭ pin SYNC signal. Measure ⑳ pin.	2.5	3.0	3.5	μs
τHP	HP pulse timing	18	Input ⑭ pin SYNC signal. Measure ⑳ pin.	1.5	2.0	2.5	μs
PWHP	HP pulse width	18	Input ⑭ pin SYNC signal. Measure ⑳ pin.	2.3	3.8	4.3	μs
τBGP	BGP timing	18	Input ⑭ pin SYNC signal. Measure ⑳ pin.	3.3	3.8	4.3	μs
PWBGP	BGP width	18	Input ⑭ pin SYNC signal. Measure ⑳ pin.	3.9	4.4	4.9	μs
SLD	SIDE LOCK DET dead zone	19	Input ⑳ pin frequency variable 1 Vp-p. Input ⑭ pin SYNC signal. Measure ⑳ pin.	-10		10	kHz
THPSN1	P/S/N switchover threshold	10	Apply variable voltage to ⑩ pin. Input ④ pin 630 kHz, 0.25 Vp-p sine wave. Input ⑭ pin SYNC signal. Measure ⑩ pin for amplitude.	0.9	1.1	1.3	V
THPSN2	P/S/N switchover threshold	20	Apply variable voltage to ⑩ pin. Measure ⑬ pin.	3.0	3.2	3.4	V
THSLE1	2/4/6 switchover threshold 1	10	Input ④ pin 630 kHz, 0.25 Vp-p. Input ⑭ pin SYNC signal. Apply variable voltage to ⑩ pin. Measure ⑩ pin.	0.9	1.1	1.3	V
THSLE2	2/4/6 switchover threshold 2	10	Input ④ pin 630 kHz, 0.25 Vp-p. Input ⑭ pin SYNC signal. Apply variable voltage to ⑩ pin. Measure ⑩ pin.	3.0	3.2	3.4	V
THRTP1	R/T/P switchover threshold 1	3	Input ⑫ pin 630 kHz, 0.25 Vp-p sine wave. Measure ⑬ pin.	0.9	1.1	1.3	V
THRTP2	R/T/P switchover threshold 2	7	Input ① pin standard down-converted chroma signal. Input ⑭ pin SYNC signal. Apply variable voltage to ④ pin. Measure ⑰ pin.	3.0	3.2	3.4	V
SLDFREE1	SIDE LOCK DET forced free running 1	19	Input ⑳ pin frequency variable 1 Vp-p. Input ⑭ pin SYNC signal. Measure ⑳ pin.	5.7			MHz
SLDFREE2	SIDE LOCK DET forced free running 2	19	Input ⑳ pin frequency variable 1 Vp-p. Input ⑭ pin SYNC signal. Measure ⑳ pin.			4.4	MHz
THRS	ROTARY SW input threshold	21	Apply variable voltage to ⑤ pin. Input ⑭ pin SYNC signal. Measure ⑮ pin.	2.2	2.5	2.8	V
THHSS	HSS input threshold	22	Input ⑭ pin SYNC signal (level variable). Measure ⑮ pin.	2.8			V
						2.2	V
THDUB	Dubbing switchover input threshold	11	Input ⑰ pin 3.58 MHz, 0.2 Vp-p sine wave. Input ⑭ pin SYNC signal. Adjust voltage at ⑮ pin to 5 V by VR. Measure ⑰ pin for burst and chroma amplitude.	80	130		kΩ

VHS SYSTEM VCR CHROMA SIGNAL PROCESSOR

ELECTRICAL CHARACTERISTICS (cont.)

Symbol	Parameter	Test point	Test conditions	Limits			Unit
				Min.	Typ.	Max.	
THCOMB	Y/C comb separation switchover input threshold	6	Input ④ pin reference chroma signal. Input ⑤ pin SYNC signal. Measure ⑬ pin for chroma output.	3.7			V
						3.1	V
VOLHP	HP "L" output voltage	23	Input ④ pin SYNC signal. Supply 0.8 mA current to ⑤ pin. Measure ⑰ pin for voltage.			0.4	V
IOHHP	HP "H" output current	23	Input ④ pin SYNC signal. Connect V _{cc} to ⑰ pin through 100 kΩ resistor. Measure ⑰ pin for voltage.	4.9		5.0	V
VOLBGP	BGP "L" output voltage	23	Input ④ pin SYNC signal. Supply 0.8 mA current to ⑤ pin. Measure ⑲ pin for voltage.			0.4	V
IOHBGP	BGP "H" output current	24	Measure current flowing between ⑲ pin and V _{cc} .			1.0	μA

ADJUSTMENT CIRCUIT

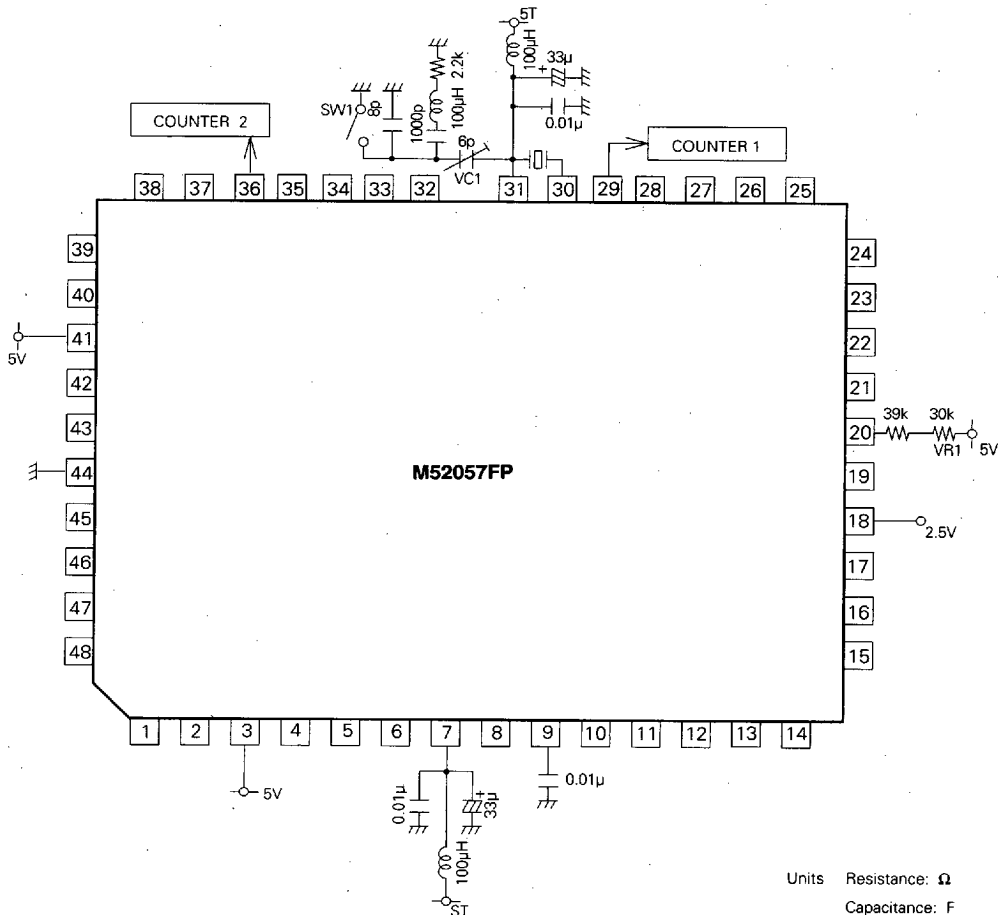

1. VCXO free running frequency adjustment Turn off SW1.
Adjust VC1 until the counter 1 indicates a frequency of 3.579545 MHz.
2. 320fH VCO free running frequency adjustment Turn SW1 on.
Adjust VR1 until the counter 2 indicates a frequency of 629.4kHz.

M52057FP

VHS SYSTEM VCR CHROMA SIGNAL PROCESSOR

TEST CIRCUIT

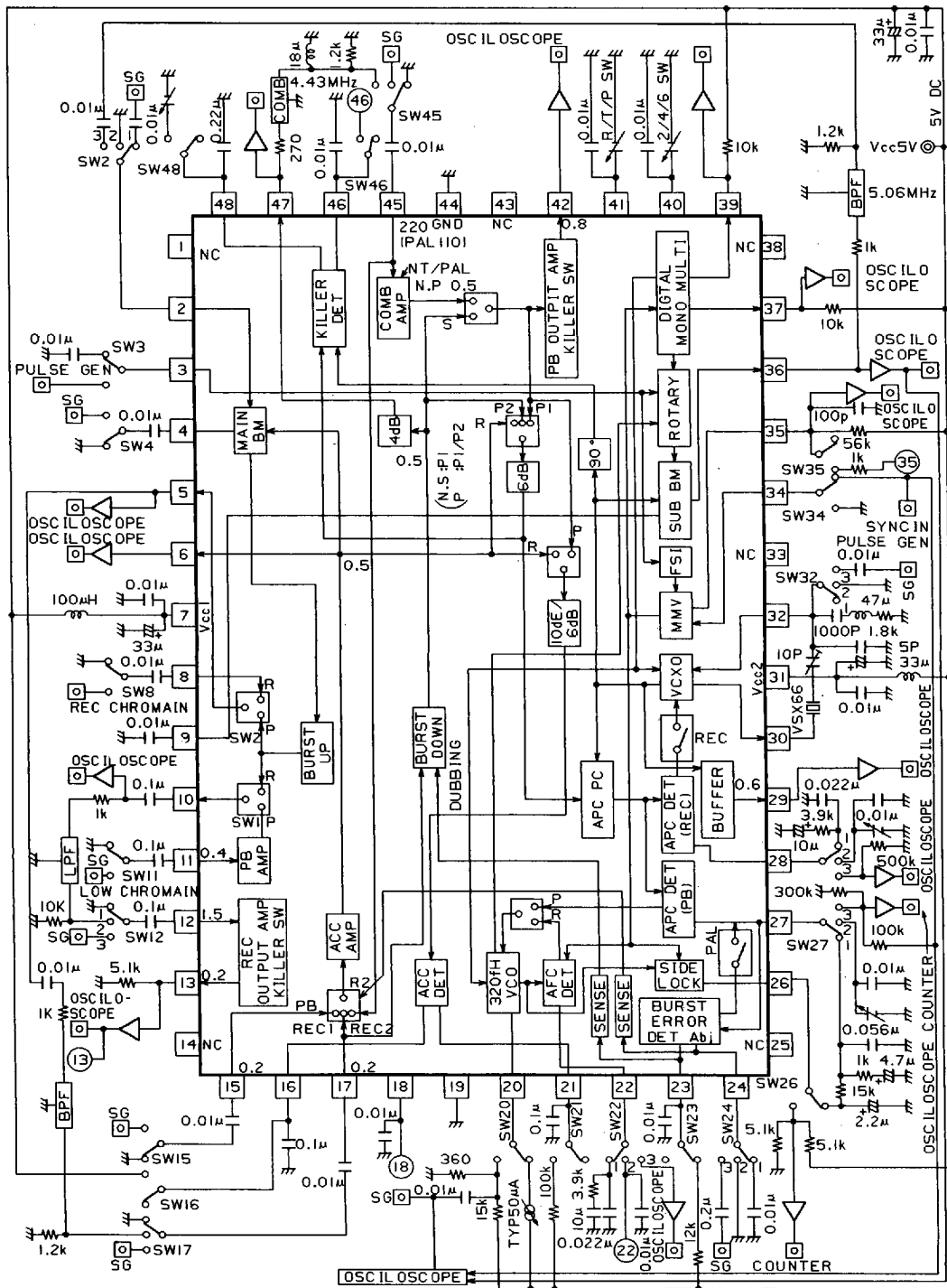

Units Resistance: Ω
Capacitance: F

6249826 0022667 628



TYPICAL CHARACTERISTICS

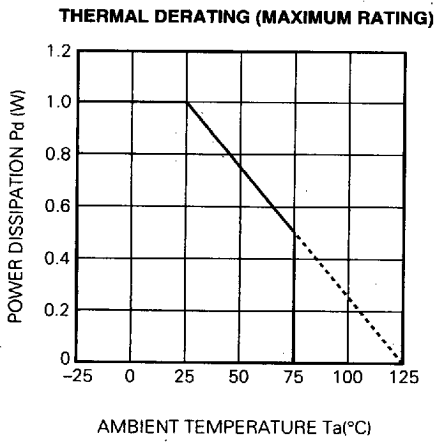

VHS SYSTEM VCR CHROMA SIGNAL PROCESSOR

APPLICATION EXAMPLE

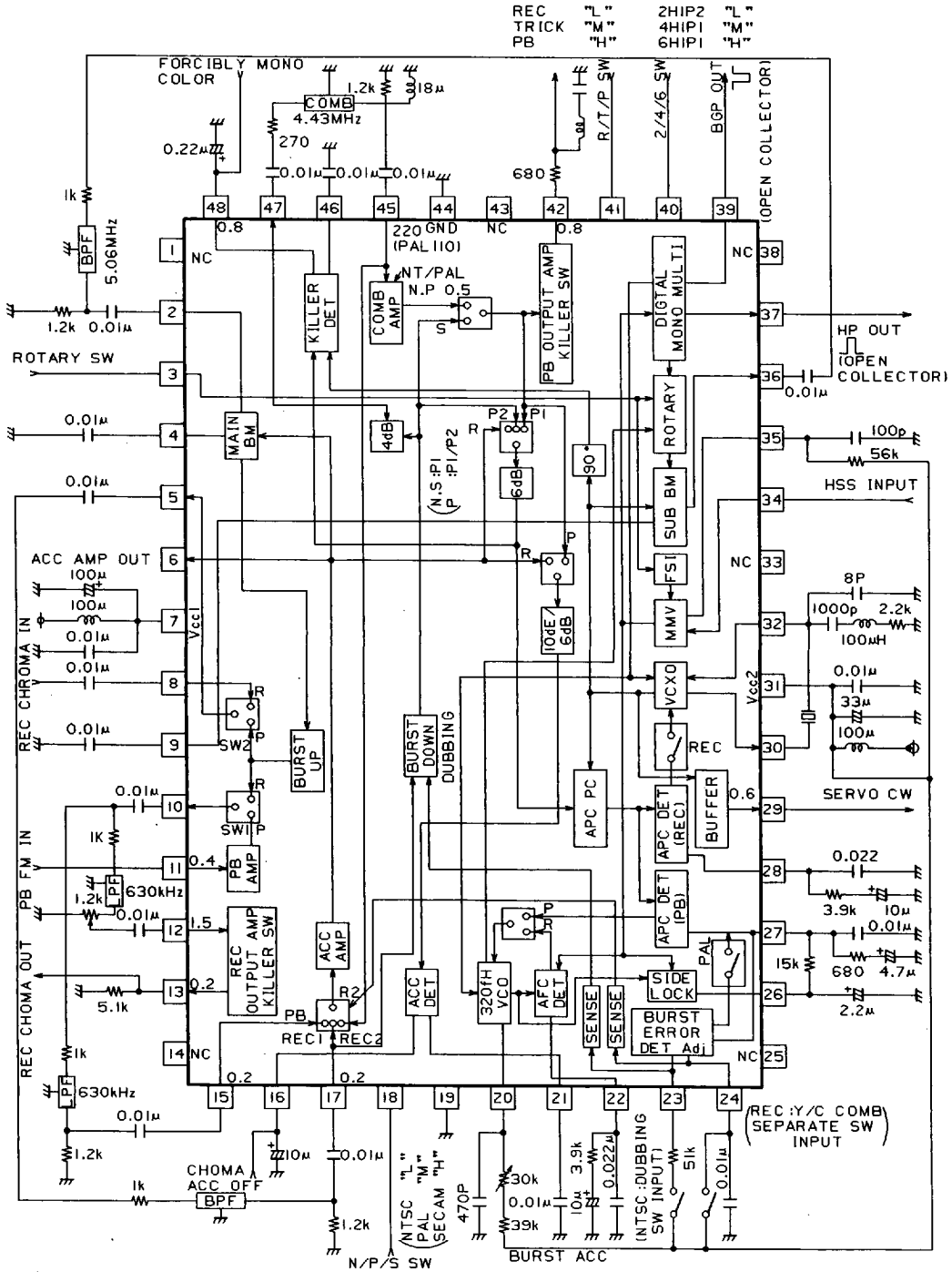

Units Resistance: Ω
Capacitance: F