

DM74LS240, DM74LS241 Octal 3-STATE Buffers/Line Drivers/Line Receivers

General Description

These buffers/line drivers are designed to improve both the performance and PC board density of 3-STATE buffers/drivers employed as memory-address drivers, clock drivers, and bus-oriented transmitters/receivers. Featuring 400 mV of hysteresis at each low current PNP data line input, they provide improved noise rejection and high fanout outputs and can be used to drive terminated lines down to 133Ω.

Features

- 3-STATE outputs drive bus lines directly
- PNP inputs reduce DC loading on bus lines
- Hysteresis at data inputs improves noise margins

- Typical I_{OL} (sink current)
 - 54LS 12 mA
 - 74LS 24 mA
- Typical I_{OH} (source current)
 - 54LS -12 mA
 - 74LS -15 mA
- Typical propagation delay times
 - Inverting 10.5 ns
 - Noninverting 12 ns
- Typical enable/disable time 18 ns
- Typical power dissipation (enabled)
 - Inverting 130 mW
 - Noninverting 135 mW

Connection Diagrams

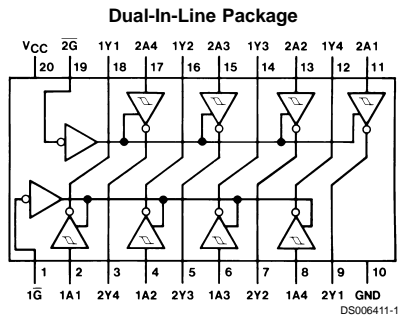

Order Number DM54LS240J,
DM54LS240W, DM54LS240E,
DM74LS240WM or DM74LS240N
See Package Number E20A, J20A,
M20B, N20A or W20A

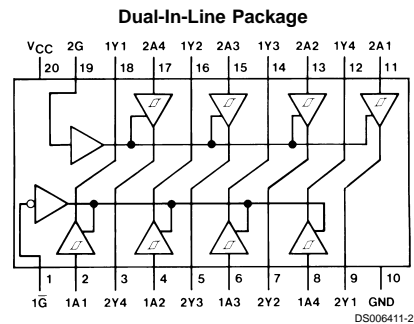

Order Number DM54LS241J,
DM54LS241W, DM54LS241E,
DM74LS241WM or DM74LS241N
See Package Number E20A, J20A,
M20B, N20A or W20A

Function Tables

LS240

Inputs		Output
\bar{G}	A	Y
L	L	H
L	H	L
H	X	Z

LS241

Inputs				Outputs	
G	\bar{G}	1A	2A	1Y	2Y
X	L	L	X	L	
X	L	H	X	H	
X	H	X	X	Z	
H	X	X	L		L
H	X	X	H		H
L	X	X	X		Z

L = Low Logic Level
H = High Logic Level
X = Either Low or High Logic Level
Z = High Impedance

Absolute Maximum Ratings (Note 1)

Supply Voltage	7V	DM54LS, 54LS	-55°C to +125°C
Input Voltage	7V	DM74LS	0°C to +70°C
Operating Free Air Temperature Range		Storage Temperature Range	-65°C to +150°C

Recommended Operating Conditions

Symbol	Parameter	DM54LS240, 241			DM74LS240, 241			Units
		Min	Nom	Max	Min	Nom	Max	
V _{CC}	Supply Voltage	4.5	5	5.5	4.75	5	5.25	V
V _{IH}	High Level Input Voltage	2			2			V
V _{IL}	Low Level Input Voltage			0.7			0.8	V
I _{OH}	High Level Output Current			-12			-15	mA
I _{OL}	Low Level Output Current			12			24	mA
T _A	Free Air Operating Temperature	-55		125	0		70	°C

Note 1: The "Absolute Maximum Ratings" are those values beyond which the safety of the device cannot be guaranteed. The device should not be operated at these limits. The parametric values defined in the "Electrical Characteristics" table are not guaranteed at the absolute maximum ratings. The "Recommended Operating Conditions" table will define the conditions for actual device operation.

Electrical Characteristics

over recommended operating free air temperature range (unless otherwise noted)

Symbol	Parameter	Conditions	Min	Typ (Note 2)	Max	Units		
V _I	Input Clamp Voltage	V _{CC} = Min, I _I = -18 mA			-1.5	V		
HYS	Hysteresis (V _{T+} - V _{T-}) Data Inputs Only	V _{CC} = Min	0.2	0.4		V		
V _{OH}	High Level Output Voltage	V _{CC} = Min, V _{IH} = Min V _{IL} = Max, I _{OH} = -1 mA	DM74	2.7		V		
		V _{CC} = Min, V _{IH} = Min V _{IL} = Max, I _{OH} = -3 mA	DM54/DM74	2.4	3.4			
		V _{CC} = Min, V _{IH} = Min V _{IL} = 0.5V, I _{OH} = Max	DM54/DM74	2				
V _{OL}	Low Level Output Voltage	V _{CC} = Min V _{IL} = Max V _{IH} = Min	I _{OL} = 12 mA I _{OL} = Max	DM74 DM54 DM74		0.4 0.4 0.5	V	
		V _{CC} = Max V _{IL} = Max	V _O = 2.7V			20		μA
		V _{CC} = Max V _{IH} = Min	V _O = 0.4V			-20		
I _I	Input Current at Maximum Input Voltage	V _{CC} = Max, V _I = 7V (DM74) V _I = 10V (DM54)			0.1	mA		
I _{IH}	High Level Input Current	V _{CC} = Max, V _I = 2.7V			20	μA		
I _{IL}	Low Level Input Current	V _{CC} = Max, V _I = 0.4V			-0.2	mA		
I _{OS}	Short Circuit Output Current	V _{CC} = Max (Note 3)			-40	-225	mA	
I _{CC}	Supply Current	V _{CC} = Max, Outputs Open	Outputs High	LS240, LS241		13	23	mA
			Outputs Low	LS240		26	44	
				LS241		27	46	
			Outputs Disabled	LS240		29	50	
				LS241		32	54	

Note 2: All typicals are at V_{CC} = 5V, T_A = 25°C.

Note 3: Not more than one output should be shorted at a time, and the duration should not exceed one second.

Switching Characteristics

at $V_{CC} = 5V$ and $T_A = 25^\circ C$

Symbol	Parameter	Conditions		DM54LS	DM74LS	Units
				Max	Max	
t_{PLH}	Propagation Delay Time Low to High Level Output	$C_L = 45 \text{ pF}$ $R_L = 667\Omega$	LS240	18	14	ns
			LS241	18	18	
t_{PHL}	Propagation Delay Time High to Low Level Output	$C_L = 45 \text{ pF}$ $R_L = 667\Omega$	LS240	18	18	ns
			LS241	18	18	
t_{PZL}	Output Enable Time to Low Level	$C_L = 45 \text{ pF}$ $R_L = 667\Omega$	LS240	30	30	ns
			LS241	30	30	
t_{PZH}	Output Enable Time to High Level	$C_L = 45 \text{ pF}$ $R_L = 667\Omega$	LS240	23	23	ns
			LS241	23	23	
t_{PLZ}	Output Disable Time from Low Level	$C_L = 5 \text{ pF}$ $R_L = 667\Omega$	LS240	25	25	ns
			LS241	25	25	
t_{PHZ}	Output Disable Time from High Level	$C_L = 5 \text{ pF}$ $R_L = 667\Omega$	LS240	18	18	ns
			LS241	18	18	
t_{PLH}	Propagation Delay Time Low to High Level Output	$C_L = 150 \text{ pF}$ $R_L = 667\Omega$	LS240		18	ns
			LS241		21	
t_{PHL}	Propagation Delay Time High to Low Level Output	$C_L = 150 \text{ pF}$ $R_L = 667\Omega$	LS240		22	ns
			LS241		22	
t_{PZL}	Output Enable Time to Low Level	$C_L = 150 \text{ pF}$ $R_L = 667\Omega$	LS240		33	ns
			LS241		33	
t_{PZH}	Output Enable Time to High Level	$C_L = 150 \text{ pF}$ $R_L = 667\Omega$	LS240		26	ns
			LS241		26	

Note 4: 54LS Output load is $C_L = 50 \text{ pF}$ for t_{PLH} , t_{PHL} , t_{PZL} and t_{PZH} .

Physical Dimensions inches (millimeters) unless otherwise noted

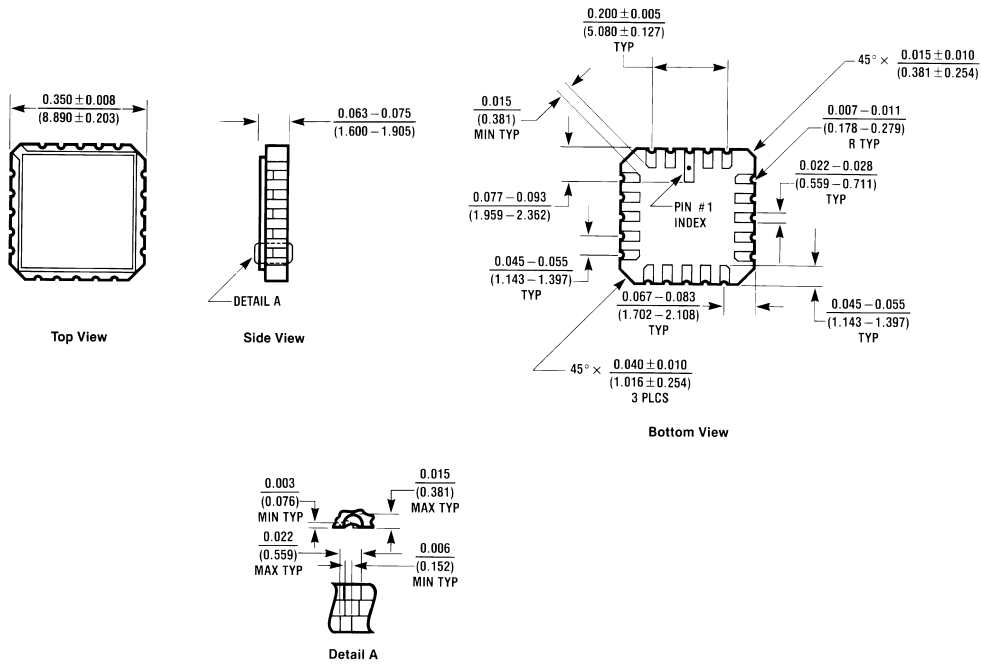

E20A (REV D)

Ceramic Leadless Chip Carrier Package (E)
Order Number DM54LS240E or DM54LS241E
Package Number E20A

Physical Dimensions inches (millimeters) unless otherwise noted (Continued)

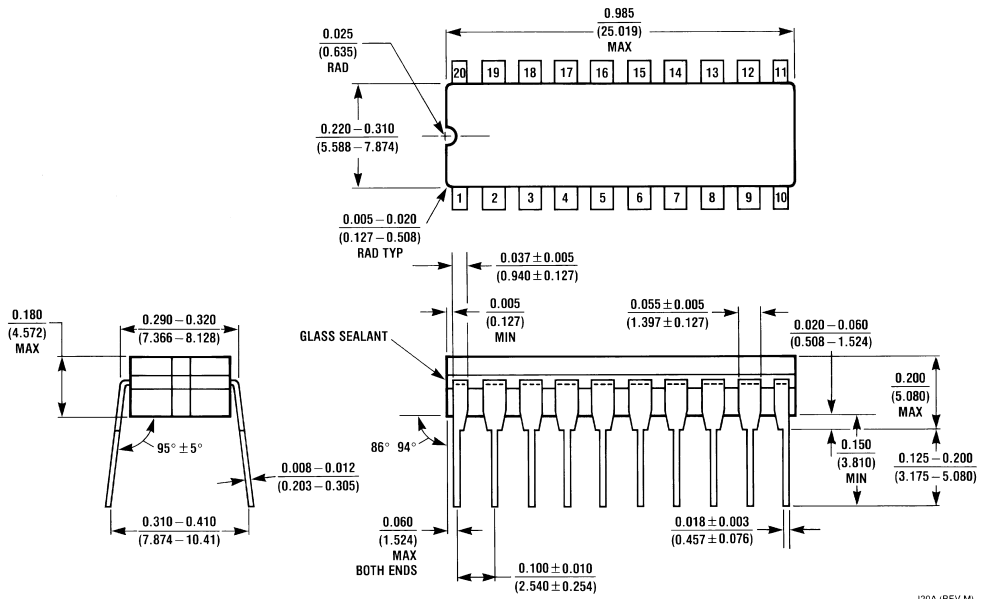

20-Lead Ceramic Dual-In-Line Package (J)
Order Number DM54LS240J or DM54LS241J
Package Number J20A

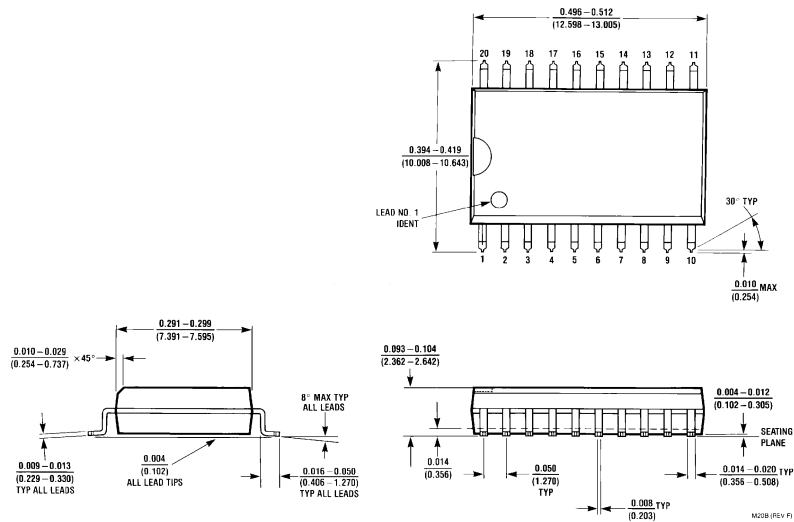

20-Lead Wide Small Outline Molded Package (M)
Order Number DM74LS240WM or DM74LS241WM
Package Number M20B

Physical Dimensions inches (millimeters) unless otherwise noted (Continued)

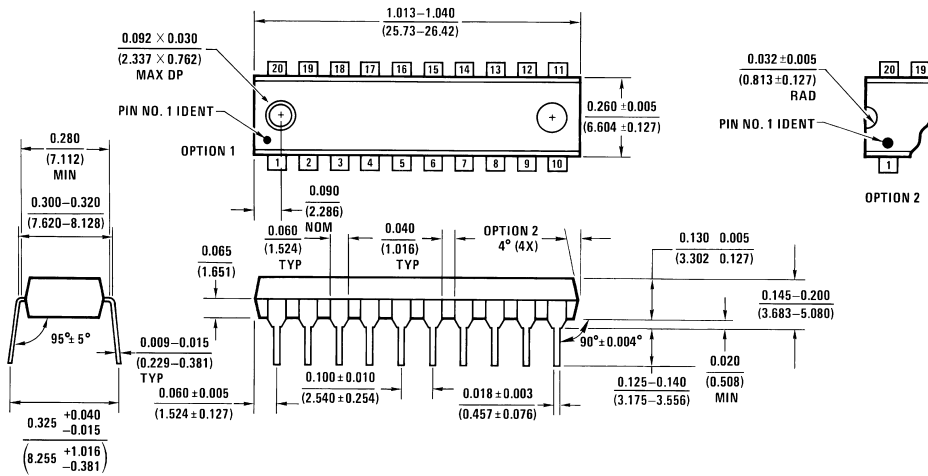

N20A (REV GI)

20-Lead Molded Dual-In-Line Package (N)
Order Number DM74LS240N or DM74LS241N
Package Number N20A

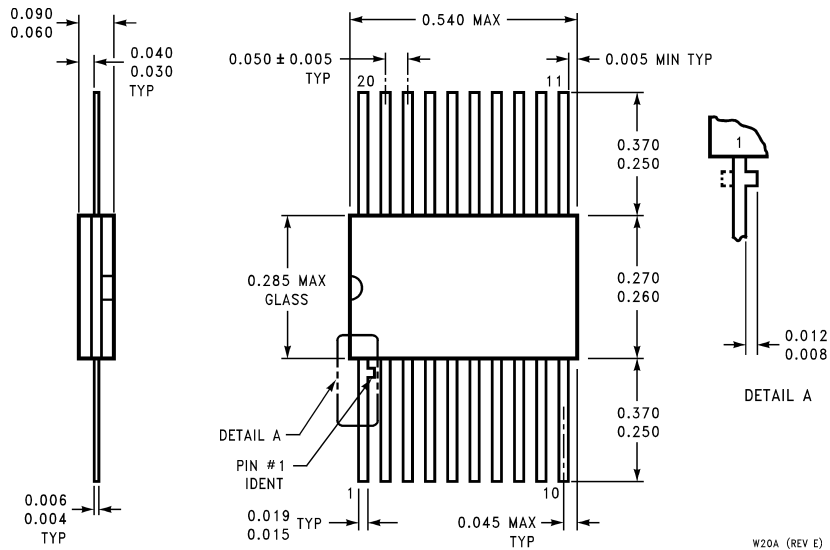

W20A (REV E)

20-Lead Ceramic Flat Package (W)
Order Number DM54LS240W or DM54LS241W
Package Number W20A

LIFE SUPPORT POLICY

FAIRCHILD'S PRODUCTS ARE NOT AUTHORIZED FOR USE AS CRITICAL COMPONENTS IN LIFE SUPPORT DEVICES OR SYSTEMS WITHOUT THE EXPRESS WRITTEN APPROVAL OF THE PRESIDENT OF FAIRCHILD SEMICONDUCTOR CORPORATION. As used herein:

1. Life support devices or systems are devices or systems which, (a) are intended for surgical implant into the body, or (b) support or sustain life, and (c) whose failure to perform when properly used in accordance with instructions for use provided in the labeling, can be reasonably expected to result in a significant injury to the user.
2. A critical component in any component of a life support device or system whose failure to perform can be reasonably expected to cause the failure of the life support device or system, or to affect its safety or effectiveness.

Fairchild Semiconductor Corporation Americas
Customer Response Center
Tel: 1-888-522-5372

Fairchild Semiconductor Europe
Fax: +49 (0) 1 80-530 85 86
Email: europe.support@nsc.com
Deutsch Tel: +49 (0) 8 141-35-0
English Tel: +44 (0) 1 793-85-68-56
Italy Tel: +39 (0) 2 57 5631

Fairchild Semiconductor Hong Kong Ltd.
13th Floor, Straight Block,
Ocean Centre, 5 Canton Rd.
Tsimshatsui, Kowloon
Hong Kong
Tel: +852 2737-7200
Fax: +852 2314-0061

National Semiconductor Japan Ltd.
Tel: 81-3-5620-6175
Fax: 81-3-5620-6179

www.fairchildsemi.com