

TRIPLE DIFFUSED PLANER TYPE
 HIGH POWER DARLINGTON
 HIGH VOLTAGE, HIGH SPEED SWITCHING

Features

- High voltage, High speed switching
- High reliability

Applications

- Switching regulators
- Ultrasonic generators
- High frequency inverters
- General purpose power amplifiers

Maximum ratings and characteristics

● Absolute maximum ratings (Tc=25°C unless otherwise specified)

Item	Symbol	Ratings	Unit
Collector-Base voltage	V _{CB0}	900	V
Collector-Emitter voltage	V _{CE0}	800	V
Emitter-Base voltage	V _{EB0}	7	V
Collector current	I _C	7	A
Base current	I _B	3	A
Collector power dissipation	P _C	80	W
Operating junction temperature	T _j	+150	°C
Storage temperature	T _{stg}	-55 to +150	°C

● Electrical characteristics (Tc =25°C unless otherwise specified)

Item	Symbol	Test Conditions	Min.	Typ.	Max.	Units
Collector-Base voltage	V _{CB0}	I _{CBO} = 1mA	900			V
Collector-Emitter voltage	V _{CE0}	I _{CEO} = 10mA	800			V
Emitter-Base voltage	V _{EB0}	I _{EBO} = 50mA	7			V
Collector-Base leakage current	I _{CBO}	V _{CB0} = 900V			1.0	mA
Emitter-Base leakage current	I _{EBO}	V _{EB0} = 7V			50	mA
D.C. current gain	h _{FE}	I _C = 3A, V _{CE} = 5V	8			
Collector-Emitter saturation voltage	V _{CE(Sat)}	I _C = 3A, I _B = 0.6A			2.0	V
Base-Emitter saturation voltage	V _{BE(Sat)}				2.5	V
*1 Switching time	t _{on}	I _C = 3A, I _{B1} = 0.6A			0.5	μs
	t _{stg}	I _{B2} = -1.2A, R _L = 100 ohm			2.5	μs
	t _f	P _w = 20μs Duty=<2%			0.8	μs

Thermal characteristics

Item	Symbol	Test Conditions	Min.	Typ.	Max.	Units
Thermal resistance	R _{th(j-c)}	Junction to case			1.55	°C/W

Outline Drawings

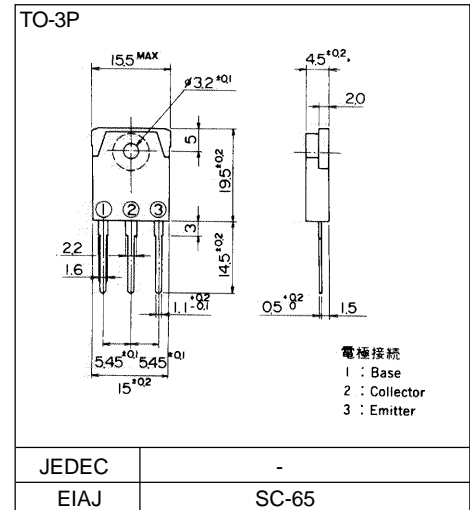

Equivalent Circuit Schematic

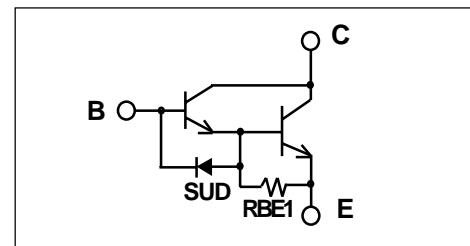

Characteristics

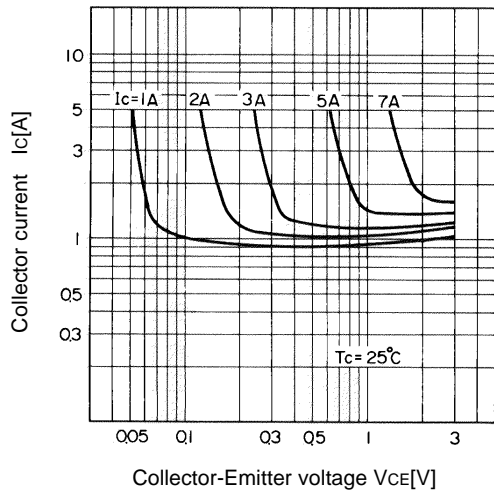

Collector Output Characteristics

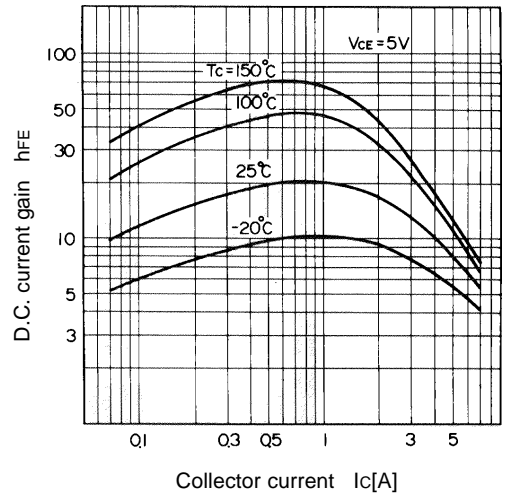

DC Current Gain

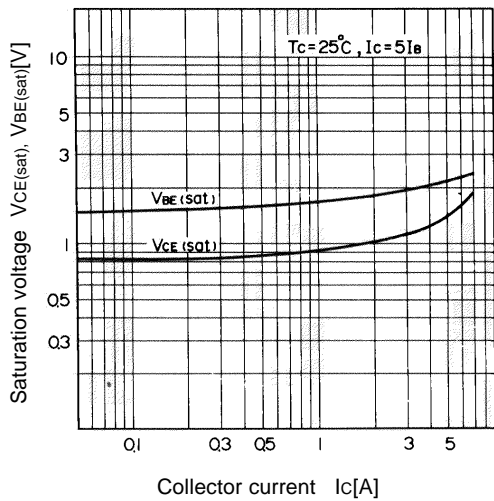

Base and Collector Saturation Voltage

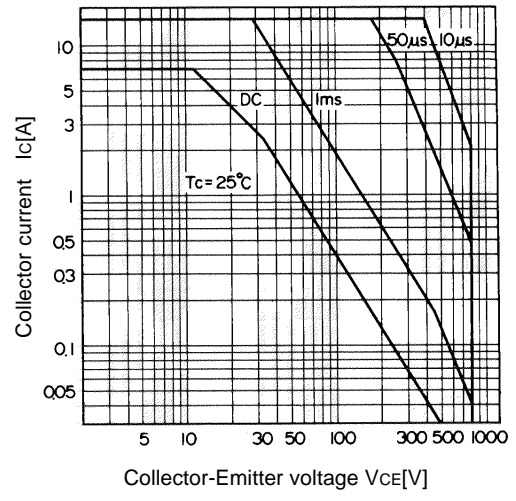

Safe Operating Area

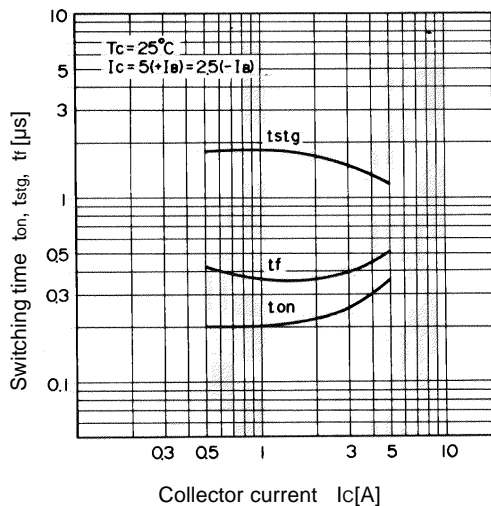

Switching Time

*1 Switching Time Test Circuit

