

AM-FM QUALITY RADIO

The TDA1220B is a monolithic integrated circuit in a 16-lead dual in-line package.

It is intended for quality receivers produced in large quantities.

The functions incorporated are:

AM SECTION

- Preamplifier and double balanced mixer
- One pin local oscillator
- IF amplifier with internal AGC
- Detector and audio preamplifier

FM SECTION

- IF amplifier and limiter
- Quadrature detector
- Audio preamplifier

The TDA1220B is suitable up to 30MHz AM and for FM bands (including 450KHz narrow band) and features:

- Very constant characteristics (3V to 16V)
- High sensitivity and low noise
- Very low tweet

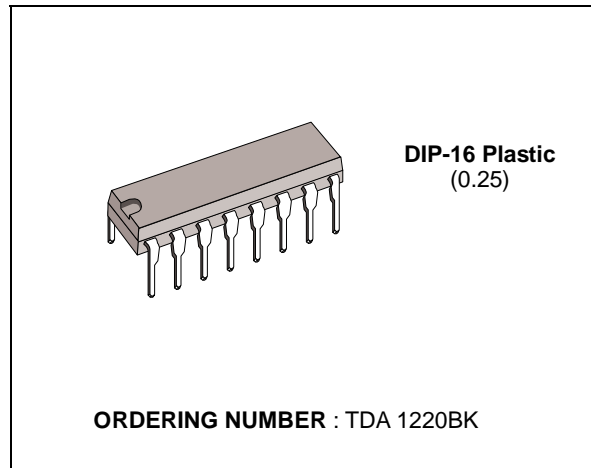

- Sensitivity regulation facility (*)
- High recovered audio signal suited for stereo decoders and radio recorders
- Very simple DC switching of AM-FM
- Low current drain
- AFC facility

(*) Maximum AM sensitivity can be reduced by means of a resistor (5 to 12K Ω) between pin 4 and ground.

BLOCK DIAGRAM

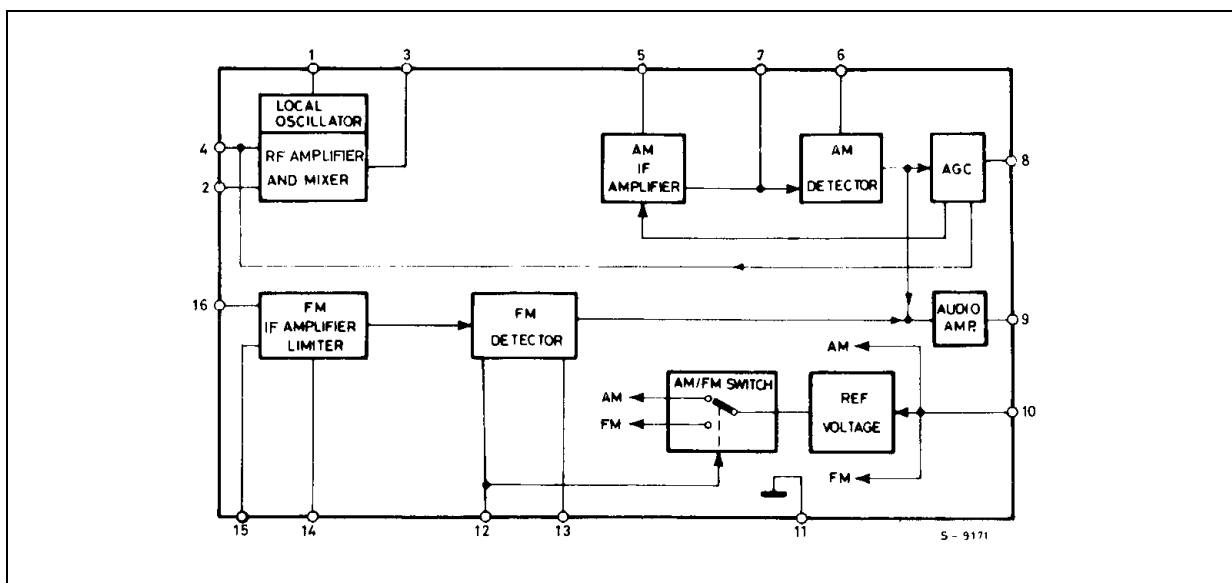

ABSOLUTE MAXIMUM RATINGS

| Symbol | Parameter | Value | Unit |
|----------------|---|------------|-------------|
| V_s | Supply voltage | 16 | V |
| P_{tot} | Total power dissipation at $T_{amb} < 110^{\circ}C$ | 400 | mW |
| T_{op} | Operating temperature | -20 to 85 | $^{\circ}C$ |
| T_{stg}, T_j | Storage and junction temperature | -55 to 150 | $^{\circ}C$ |

PIN CONNECTION
(Top view)

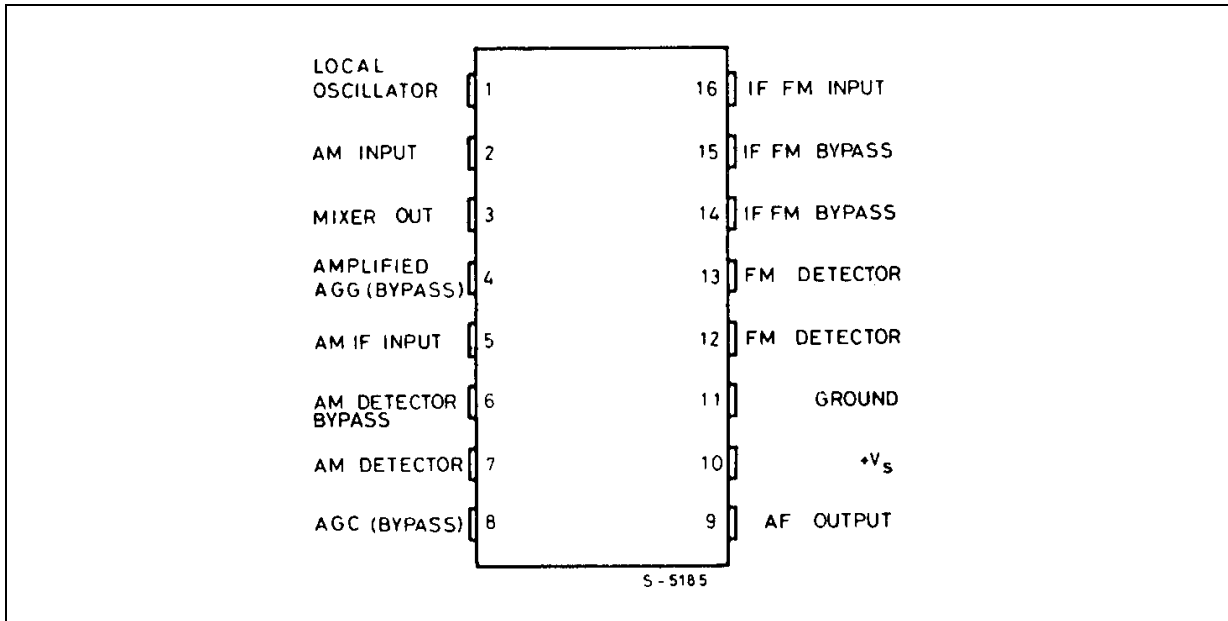

THERMAL DATA

| Symbol | Parameter | Value | Unit |
|----------------|-------------------------------------|---------|---------------|
| $R_{th-j-amb}$ | Thermal resistance junction-ambient | max 100 | $^{\circ}C/W$ |

ELECTRICAL CHARACTERISTICS ($T_{amb} = 25\text{ }^{\circ}\text{C}$, $V_s = 9\text{V}$ unless otherwise specified, refer to test circuit)

| Symbol | Parameter | Test conditions | Min. | Typ. | Max. | Unit |
|--------|----------------|-----------------|------|------|------|------|
| V_s | Supply voltage | | 3 | | 16 | V |
| I_d | Drain current | FM | | 10 | 15 | mA |
| | | AM | | 14 | 20 | mA |

AM SECTION ($f_o = 1\text{ MHz}$; $f_m = \text{KHz}$)

| | | | | | | | |
|-------|--|---------------------------------|---------------------|-----|-----|-----|------------------|
| V_i | Input sensitivity | S/N = 26 dB | $m = 0.3$ | | 12 | 25 | μV |
| S/N | | $V_i = 10\text{ mV}$ | $m = 0.3$ | 45 | 52 | | dB |
| V_i | AGC range | $\Delta V_{out} = 10\text{ dB}$ | $m = 0.8$ | 94 | 100 | | dB |
| V_o | Recovered audio signal (pin 9) | $V_i = 1\text{ mV}$ | $m = 0.3$ | 80 | 130 | 200 | mV |
| d | Distortion | $V_i = 1\text{ mV}$ | $m = 0.3$ | | 0.4 | 1 | % |
| | | | $m = 0.8$ | | 1.2 | | % |
| V_H | Max input signal handling capability | $m = 0.8$ | $d < 10\%$ | 1 | | | V |
| R_i | Input resistance between pins 2 and 4 | $m = 0$ | | | 7.5 | | $\text{K}\Omega$ |
| C_i | Input capacitance between pins 2 and 4 | $m = 0$ | | | 18 | | pF |
| R_o | Output resistance (pin 9) | | | 4.5 | 7 | 9.5 | $\text{K}\Omega$ |
| | Tweet 2 IF | $m = 0.3$ | $V_i = 1\text{ mV}$ | | 40 | | dB |
| | Tweet 3 IF | | | | 55 | | dB |

FM SECTION ($f_o = 10.8\text{ MHz}$; $f_m = 1\text{ KHz}$)

| | | | | | | | |
|-------|---|----------------------------------|---------------------|-----|------|-----|------------------|
| V_i | Input limiting voltage | -3 dB limiting point | | | 22 | 36 | μV |
| AMR | Amplitude modulation rejection | $\Delta f = \pm 22.5\text{ KHz}$ | $m = 0.3$ | 40 | 50 | | dB |
| | | $V_i = 3\text{ mV}$ | | | | | |
| S/N | Ultimate quieting | $\Delta f = \pm 22.5\text{ KHz}$ | $V_i = 1\text{ mV}$ | 55 | 65 | | dB |
| d | Distortion | $\Delta f = \pm 75\text{ KHz}$ | $V_i = 1\text{ mV}$ | | 0.7 | 1.5 | % |
| d | Distortion | $\Delta f = \pm 22.5\text{ KHz}$ | $V_i = 1\text{ mV}$ | | 0.25 | 0.5 | % |
| d | Distortion (double tuned) | | | | 0.1 | | % |
| V_o | Recovered audio signal (pin 9) | $\Delta f = \pm 22.5\text{ KHz}$ | $V_i = 1\text{ mV}$ | 80 | 110 | 140 | mV |
| R_i | Input resistance between pin 16 and ground | | | | 6.5 | | $\text{K}\Omega$ |
| C_i | Input capacitance between pin 16 and ground | | | | 14 | | pF |
| R_o | Output resistance (pin 9) | | | 4.5 | 7 | 9.5 | $\text{K}\Omega$ |

Figure 1. Test circuit

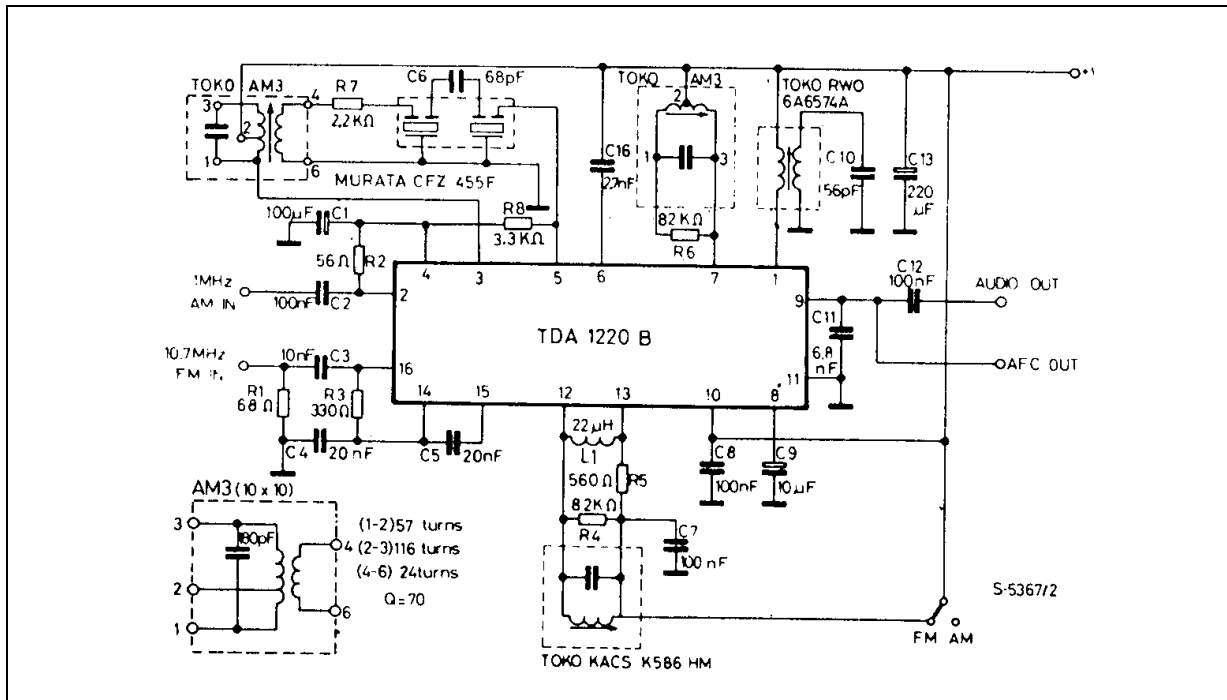

Figure 2. PC board and component layout (1:1 scale) of the test circuit

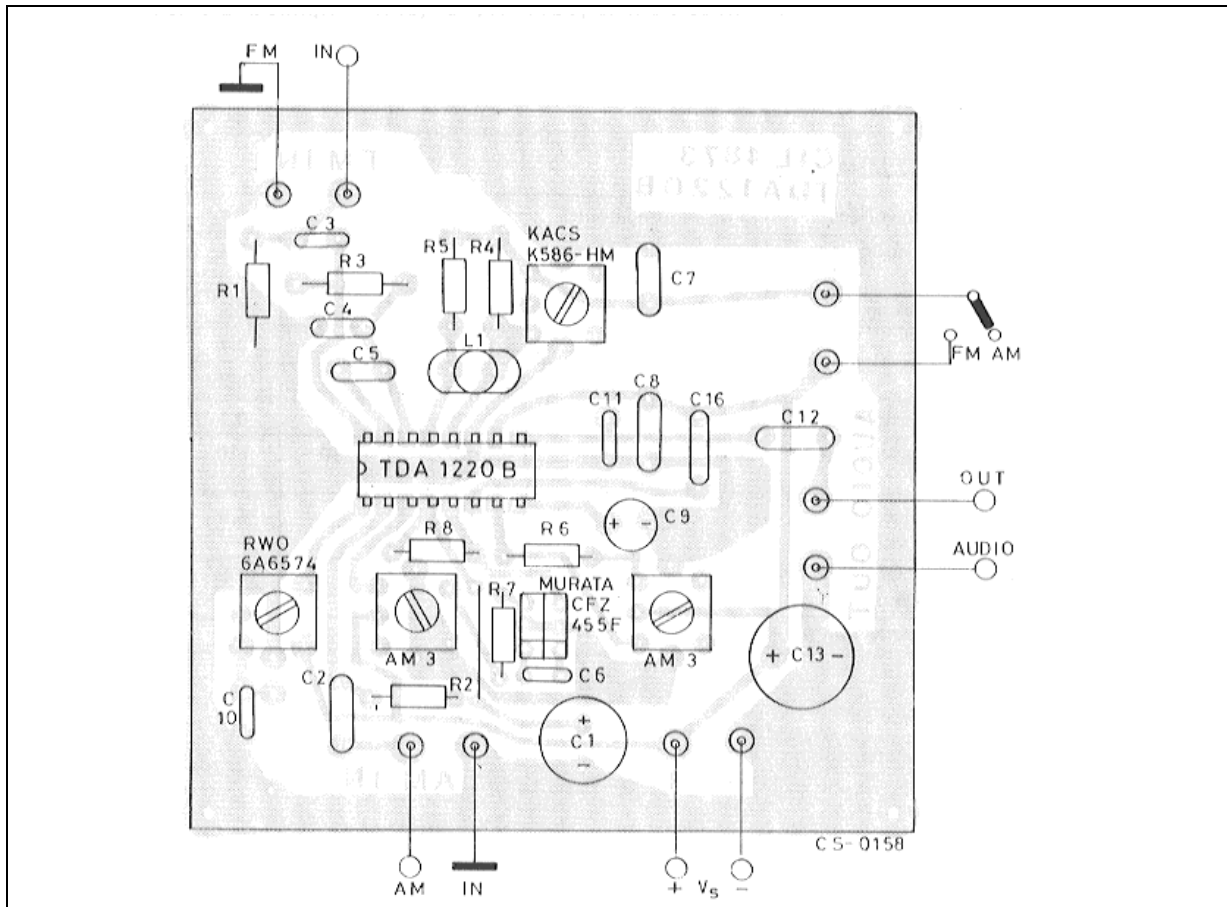

Figure 3. Audio output, noise and tweet levels vs. input signal (AM section)

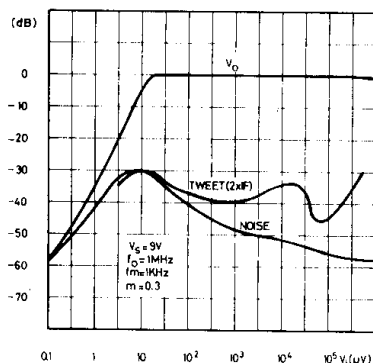

Figure 4. Distortion vs. input signal and modulation index (AM section)

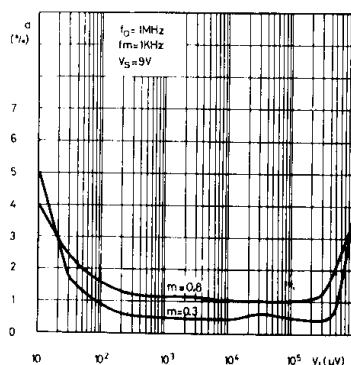

Figure 5. Audio output vs. supply voltage (AM section)

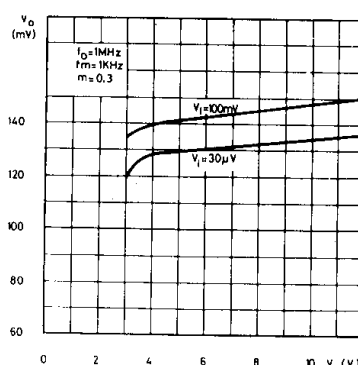

Figure 6. Audio output and noise level vs. input signal (FM section)

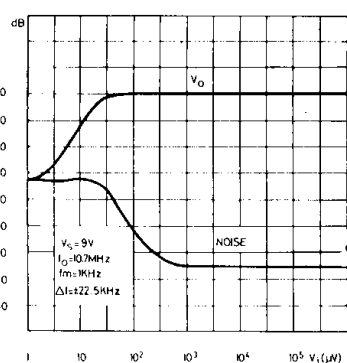

Figure 7. Distortion vs. input signal (FM section)

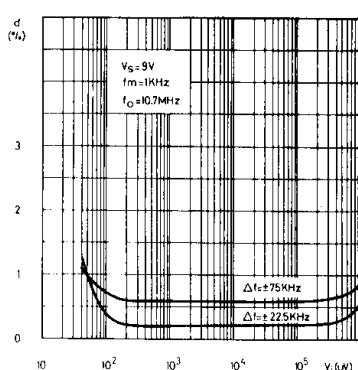

Figure 8. Audio output vs. supply voltage (FM section)

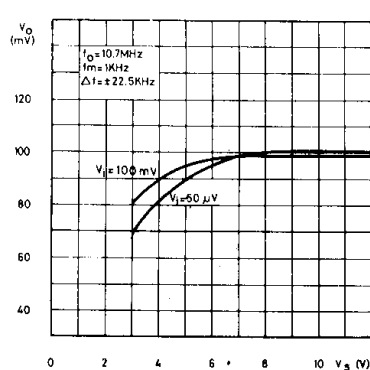

Figure 9. Amplitude modulation rejection vs. input signal (FM section)

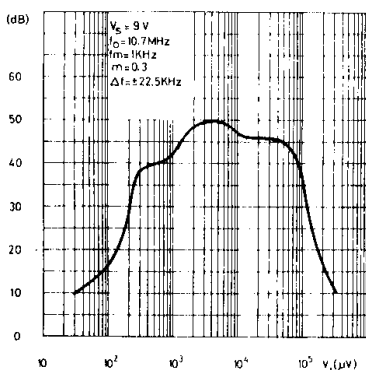

Figure 10. Delta DC output voltage (pin. 9) vs. frequency shift (FM section)

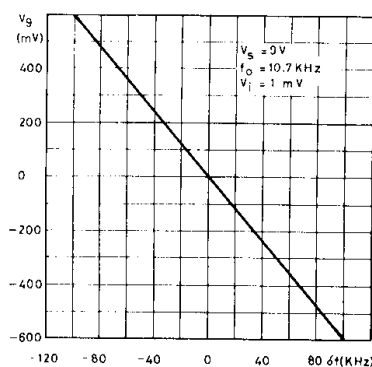
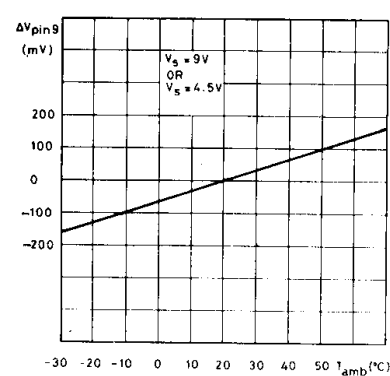

Figure 11. Delta DC output voltage (pin 9) vs. ambient temperature (FM section)



APPLICATION INFORMATION

AM Section

RF Amplifier and mixer stages

The RF amplifier stage (pin 2) is connected directly to the secondary winding of the ferrite rod antenna or input tuned circuit. Bias is provided at pin 4 which must be adequately decoupled. The RF amplifier provides stable performance extending beyond 30 MHz.

The Mixer employed is a double - balanced multiplier and the IF output at pin 3 is connected directly to the IF filter coil.

Local oscillator

The local oscillator is a cross coupled differential stage which oscillates at the frequency determined by the load on pin 1.

The oscillator resonant circuit is transformer coupled to pin 1 to improve the **Q** factor and frequency stability. The oscillator level at pin 1 is about 100 mV rms and the performance extends beyond 30 MHz, however to enhance the stability and reduce to a minimum pulling effects of the AGC operation or supply voltage variations, a high C/L ratio should be used above 10 MHz.

An external oscillator can be injected at pin 1. The level should be 50 mV rms and pin 1 should be connected to the supply via a 100W resistor.

IF Amplifier Detector

The IF amplifier is a wide band amplifier with a tuned output stage.

The IF filters can be either LC or mixed LC/ceramic.

AM detection occurs at pin 7. A detection capacitor is connected to pin 6 to reduce the radiation of spurious detector products.

The Audio output is at pin 9 (for either AM or FM); the IF frequency is filtered by an external capacitor which is also used as the FM mono de-emphasis network. The audio output impedance is about 7K Ω and a high impedance load (~ 50K Ω) must be used.

AGC

Automatic gain control operates in two ways.

With weak signals it acts on the IF gain, maintaining the maximum S/N. For strong signals a second circuit intervenes which controls the entire chain and allows signal handling in excess of one volt ($m = 0.8$).

At pin 8 there is a carrier envelope signal which is filtered by an external capacitor to remove the Audio and RF content and obtain a mean DC signal to drive the AGC circuit.

APPLICATION INFORMATION (continued)**FM Section****IF Amplifier and limiter**

The 10.7 MHz IF signal from the ceramic filter is amplified and limited by a chain of four differential stages. Pin 16 is the amplifier input and has a typical input impedance of 6.5 k Ω in parallel with 14 pF at 10.7 MHz. Bias for the first stage is available at pin 14 and provides 100% DC feedback for stable operating conditions. Pin 15 is the second input to the amplifier and is decoupled to pin 14, which is grounded by a 20 nF capacitor. An RLC network is connected to the amplifier output and gives a 90° phase shift (at the IF centre frequency) between pins 13 and 12. The signal level at pin 13 is about 150 mV rms

FM Detector

The circuit uses a quadrature detector and the choice of component values is determined by the acceptable level of distortion at a given recovered audio level.

With a double tuned network the linearity improves (distortion is reduced) and the phase shift can be optimized; however this leads to a reduction in the level of the recovered audio. A satisfactory compromise for most FM receiver applications is shown in the test circuit.

Care should be taken with the physical layout.

The main recommendations are:

- Locate the phase shift coil as near as possible to pin 13.
- Shunt pins 14 and 16 with a low value resistor (between 56 Ω and 330 Ω).
- Ground the decoupling capacitor of pin 14 and the 10.7 MHz input filter at the same point.

AM-FM Switching

AM-FM switching is achieved by applying a DC voltage at pin 13, to switch the internal reference.

Typical DC voltages (refer to the test circuit)

| Pins | 1 | 2 | 3 | 4 | 5 | 6 | 7 | 8 | 9 | 10 | 11 | 12 | 13 | 14 | 15 | 16 | Unit |
|------|---|------|---|------|------|-----|---|-----|-----|----|----|-----|-----|-----|-----|-----|------|
| AM | 9 | 1.4 | 9 | 1.4 | 1.4 | 8.4 | 9 | 0.7 | 1.9 | 9 | 0 | 0.1 | 0.1 | 8.5 | 8.5 | 8.5 | V |
| FM | 9 | 0.02 | 9 | 0.02 | 0.02 | 8.5 | 9 | 0 | 1.7 | 9 | 0 | 9 | 9 | 8 | 8 | 8 | V |

APPLICATION SUGGESTION

Recommended values are referred to the test circuit of Fig. 2.

| Part number | Recommended value | Purpose | Smaller than recommended value | Larger than recommended value |
|-------------|-------------------|---|---|---|
| C1 | 100 μ F | AGC bypass | Increase of the distortion at low audio frequency | Increase of the AGC time constant |
| C2 (*) | 100 nF | AM input DC cut | | |
| C3 (*) | 10 nF | FM input DC cut | | |
| C4 C5 | 20 nF 20 nF | FM amplifier bypass | Reduction of sensitivity | - Bandwidth increase - Higher noise |
| C6 | 68 pF | Ceramic filter coupling | IF bandwidth reduction | IF bandwidth increase |
| C7 | 100 nF | FM detector decoupling | Danger of RF irradiation | |
| C8 | 100 nF | Power supply bypass | Noise increase of the audio output | |
| C9 | 10 μ F | AGC bypass | Increase of the distortion at low audio frequency | Increase of the AGC time constant |
| C10 (*) | 56 pF | Tuning of the AM oscillator at 1455 KHz | | |
| C11 | 6.8 nF | 50 μ s FM de-emphasis | | |
| C12 | 100 nF | Output DC decoupling | Low audio frequency cut | |
| C13 | 220 μ F | Power supply decoupling | Increase of the distortion at low frequency | |
| C16 | 2.7 nF | AM detector capacitor | Low suppression of the IF frequency and harmonics | Increase of the audio distortion |
| R1 (*) | 68 ohm | FM input matching | | |
| R2 (*) | 56 ohm | AM input matching | | |
| R3 | 330 ohm | Ceramic filter matching | Audio output decrease and lower distortion | |
| R4 | 8.2 Kohm | FM detector coil Q setting | Audio output decrease and higher AMR | Audio output increase and higher distortion |
| R5 | 560 ohm | FM detector load resistor | Lower IF gain and Lower AGC range | |
| R6 | 82 Kohm | AM detector coil Q setting | | Higher IF gain and lower AGC range |
| R7 | 2.2 Kohm | 455 KHz IF filter matching | | |
| R8 | 3.3 Kohm | 455 KHz IF filter matching | | |

(*) Only for test circuit

APPLICATION INFORMATION (continued)

Figure 12. Portable AM/FM radio

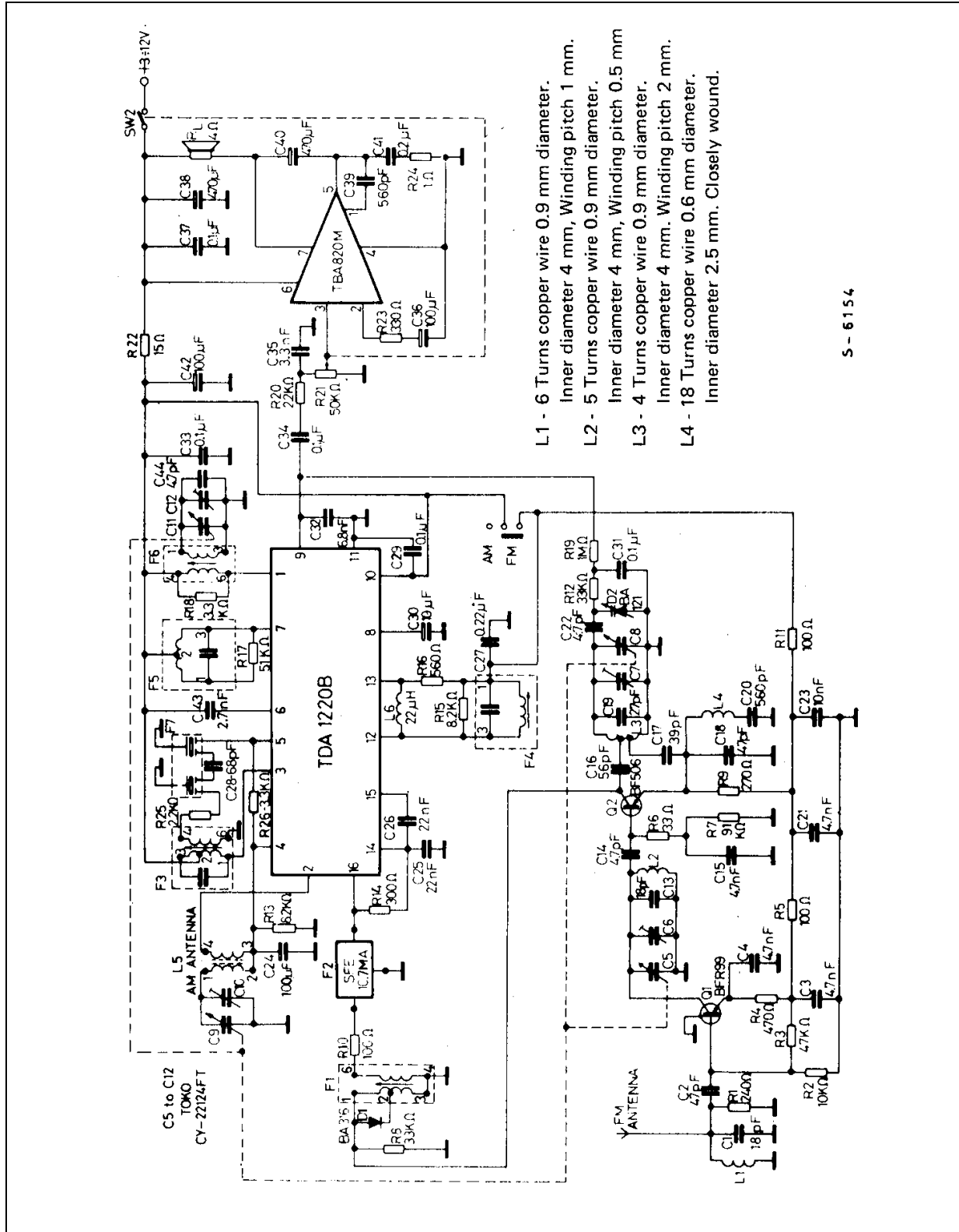

- L1 - 6 Turns copper wire 0.9 mm diameter.
Inner diameter 4 mm, Winding pitch 1 mm.
- L2 - 5 Turns copper wire 0.9 mm diameter.
Inner diameter 4 mm, Winding pitch 0.5 mm
- L3 - 4 Turns copper wire 0.9 mm diameter.
Inner diameter 4 mm. Winding pitch 2 mm.
- L4 - 18 Turns copper wire 0.6 mm diameter.
Inner diameter 2.5 mm. Closely wound.

S - 6154

APPLICATION INFORMATION (continued)

Figure 13. PC board and component layout of the fig. 12 1 : 1 scale

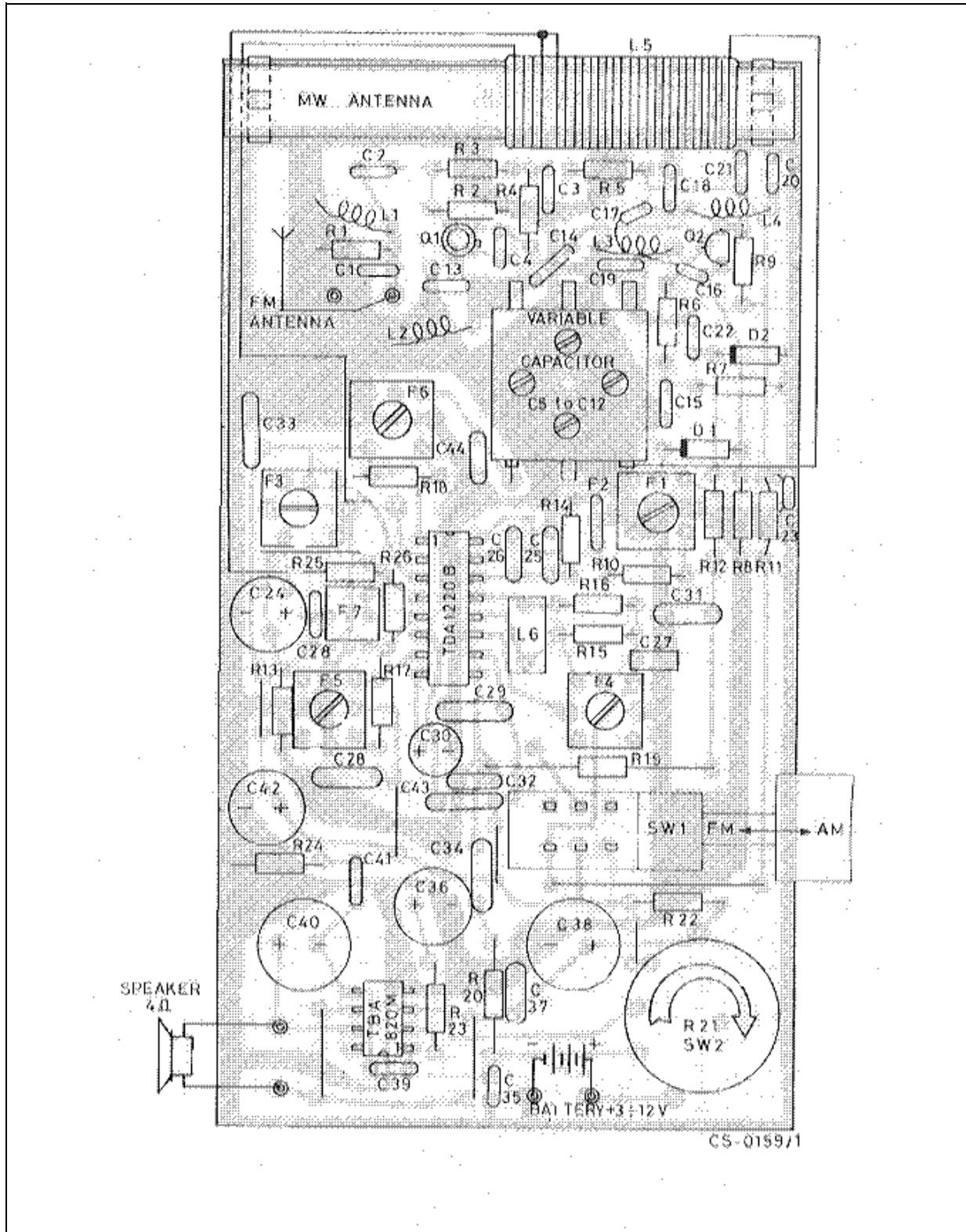

APPLICATION INFORMATION (continued)

F1 - 10.7 MHz IF Coil

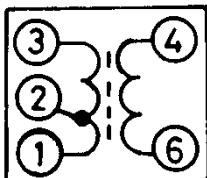

| C _o (pF) | f (MHz) | Q _o | TURNS | | |
|------------------------|------------|----------------|-------|-----|-----|
| | | | 1-2 | 2-3 | 4-6 |
| – | – | 1-3 | 1-2 | 2-3 | 4-6 |
| – | 10.7 | 110 | 6 | 8 | 2 |

TOKO - FM1 - 10x10 mm.
154 AN - 7A5965R

F3 and F5 - 455 KHz IF Coil

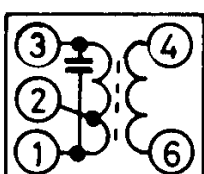

| C _o (pF) | f (KHz) | Q _o | TURNS | | |
|------------------------|------------|----------------|-------|-----|-----|
| | | | 1-2 | 2-3 | 4-6 |
| 1.3 | – | 1-3 | 1-2 | 2-3 | 4-6 |
| 180 | 455 | 70 | 57 | 116 | 24 |

TOKO - AM3 - 10x10 mm.
RLC - 4A7525N

F4 - FM Detector Coil

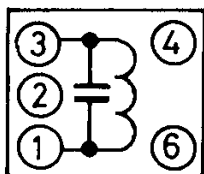

| C _o (pF) | f (KHz) | Q _o | TURNS | | |
|------------------------|------------|----------------|-------|---|---|
| | | | 1-3 | – | – |
| 1.3 | – | 1-3 | 1-3 | – | – |
| 82 | 10.7 | 100 | 12 | – | – |

TOKO - 10x10 mm.
KACS - K586 HM

F6 - AM Oscillator Coil

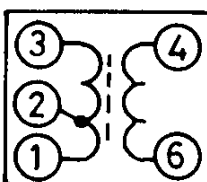

| f (kHz) | L (μH) 1-3 | Q _o | TURNS | | |
|------------|------------------|----------------|-------|-----|-----|
| | | | 1-2 | 2-3 | 4-6 |
| 796 | 220 | 80 | 2 | 75 | 8 |

TOKO - 10x10 mm.
RWO + 6A6574N

L5 - Antenna Coil

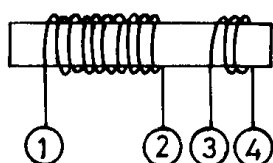

| f (KHz) | L (μH) | Q _o | TURNS | |
|------------|-----------|----------------|-------|-----|
| | | | 1-2 | 3-4 |
| 796 | | | 105 | 7 |

WIRE: LITZ - 15x0.05 mm.
CORE: 10x80 mm.

TDA1220B

APPLICATION INFORMATION (continued)

Typical performance of the radio receiver of fig. 12 ($V_s = 9V$)

| Parameter | | Test Conditions | | Value |
|--------------------------------------|--------|---|-------------------------------------|------------------|
| WAVEBANDS | FM | | | 87.5 to 108 MHz |
| | AM | | | 510 to 1620 KHz |
| SENSITIVITY | FM | S/N = 26dB | $\Delta f = 22.5\text{KHz}$ | 1 μV |
| | AM | S/N = 6dB | m = 0.3 | 1 μV |
| | AM | S/N = 26dB | m = 0.3 | 10 μV |
| DISTORTION (fm = 1KHz) | FM | $P_o = 0.5W$ | $\Delta f = 22.5\text{KHz}$ | 0.25% |
| | | | $\Delta f = 75\text{KHz}$ | 0,7% |
| | AM | $V_i = 100 \mu\text{V}$ | m = 0.3 | 0.4% |
| | | | m = 0,8 | 0,8% |
| SIGNAL TO NOISE (fm = 1KHz) | FM | $P_o = 0.5W$ $V_i = 100 \mu\text{V}$ | $\Delta f = 22.5\text{KHz}$ | 64 dB |
| | AM | $P_o = 0.5W$ $V_i = 1 \text{ mV}$ | m = 0.3 | 50 dB |
| AMPLITUDE MODULATION REJECTION | FM | $V_i = 100 \mu\text{V}$ | $\Delta f = 22.5\text{KHz}$ m = 0.3 | 50 dB |
| TWEET | 2nd H. | f = 911 KHz | | 0.3% |
| | 3rd H. | f = 1370 KHz | | 0.07% |
| QUIESCENT CURRENT | | | | 20 mA |
| SUPPLY VOLTAGE RANGE | | | | 3 to 12V |

APPLICATION INFORMATION (continued)

Figure 14. Low cost 27 MHz receiver

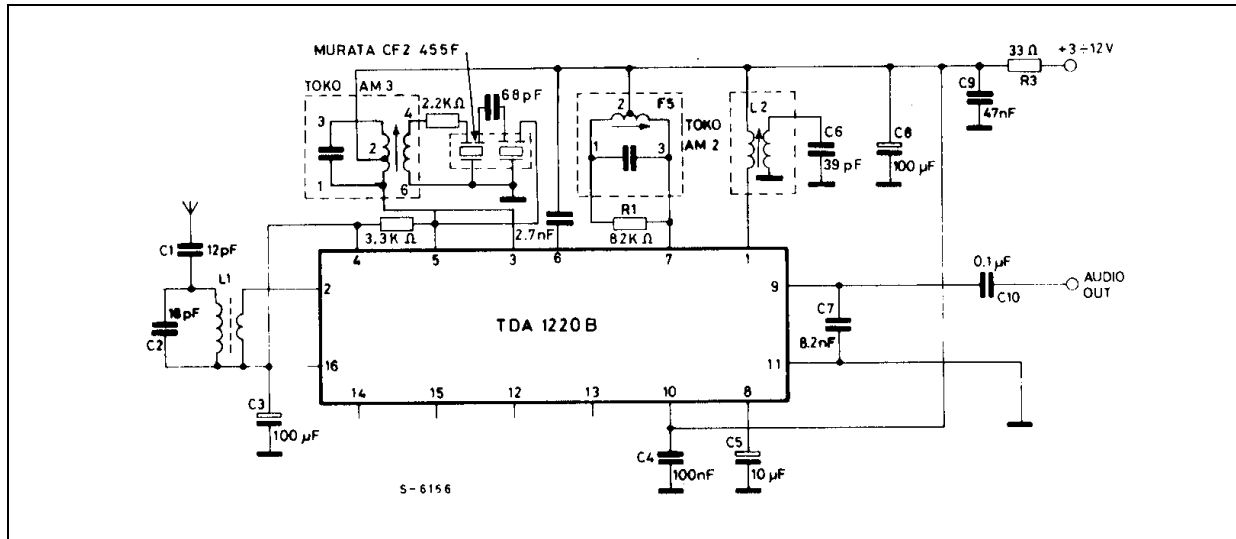
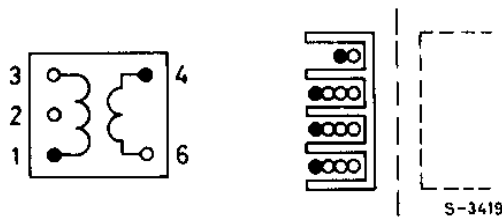
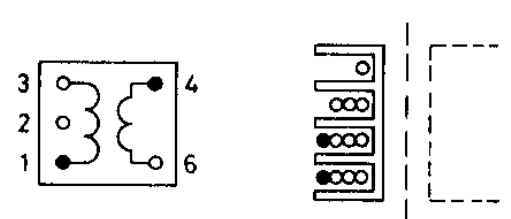

Figure 15. L2 Oscillator coil



Coil support: Toko 10K
 Primary winding: 10 Turns of enamelled copper wire 0.16 mm diameter (pins 3-1).
 Secondary winding: 4 Turns copper wire 0.16 mm diameter (pins 6-4)

Figure 16. L1 Antenna Coil



Coil support: Toko 10K
 Primary winding: as L2 (pins 3-1)
 Secondary winding: 2 Turns copper wire 0.16 mm diameter (pins 6-4)

Figure 17. Low cost 27 MHz receiver with external xtal oscillator

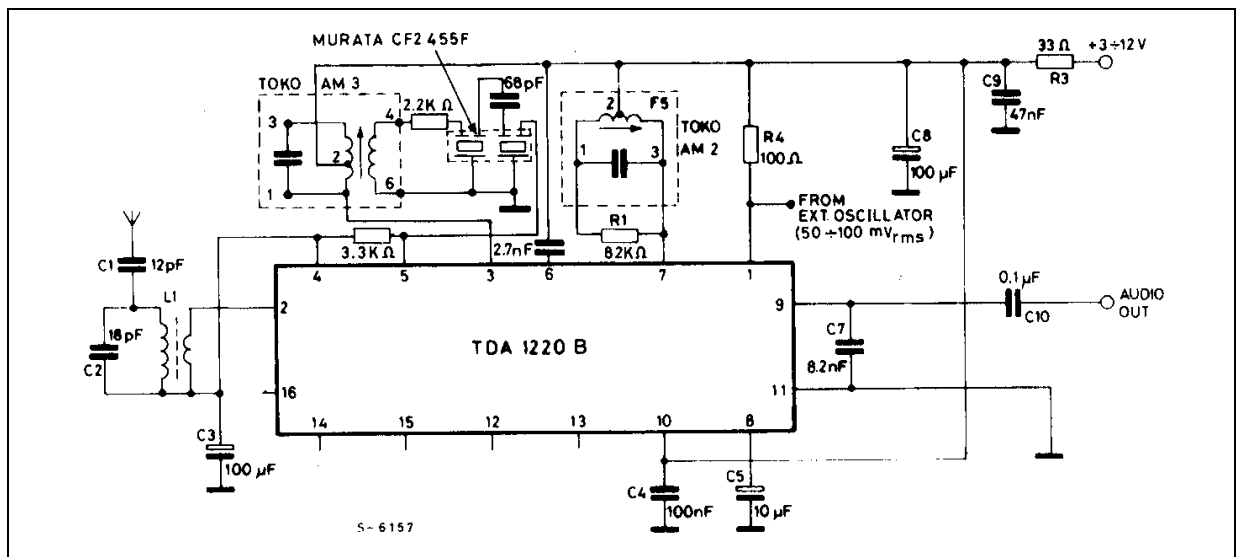

APPLICATION INFORMATION (continued)

Figure 18. 455 KHz FM narrow band IF

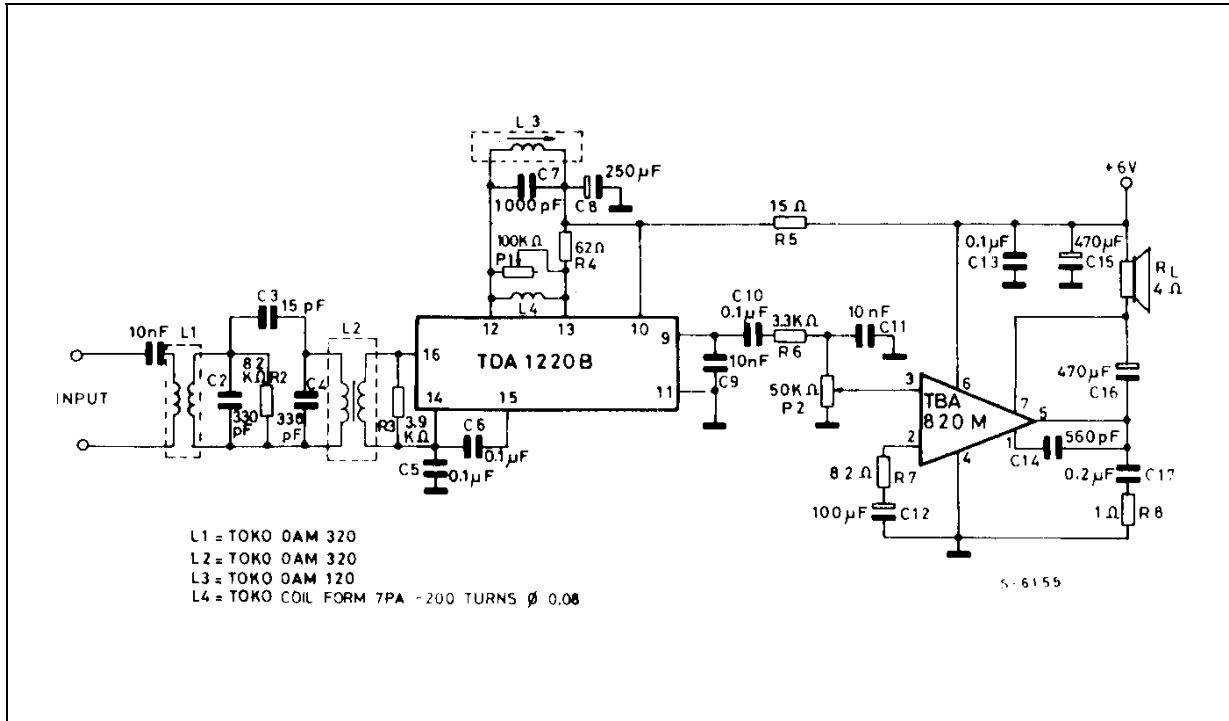
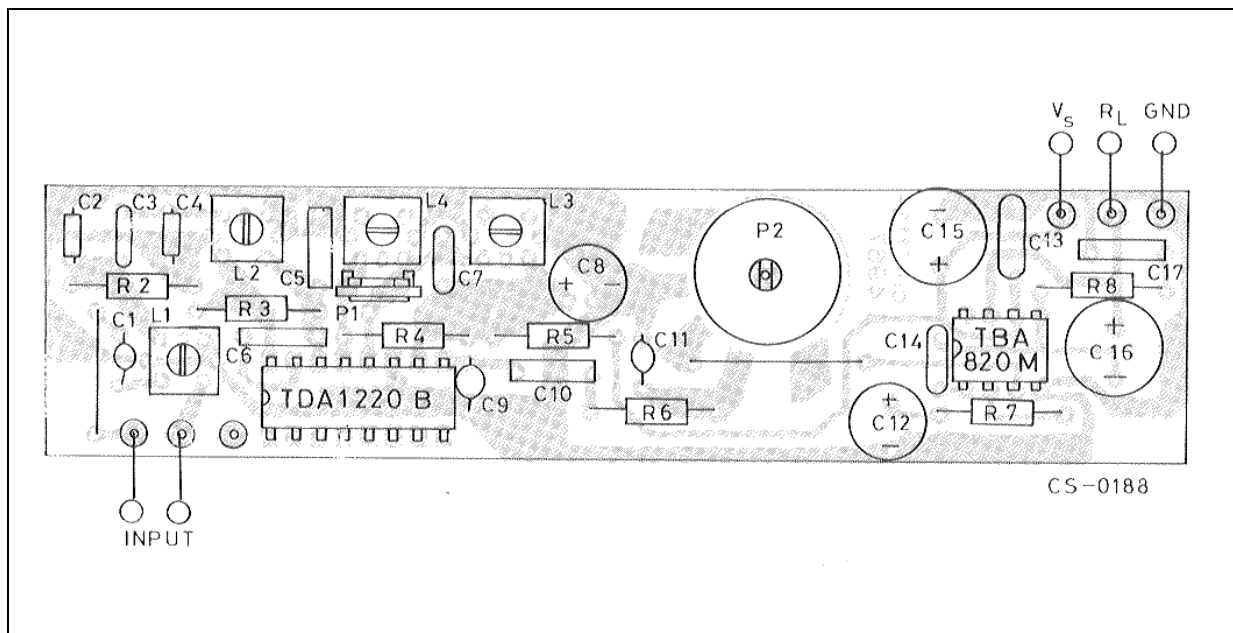

Figure 18. P.C. board and component layout of the circuit of fig. 18



APPLICATION INFORMATION (continued)

Figure 20. Discriminator "S" curve response (circuit of fig. 18)

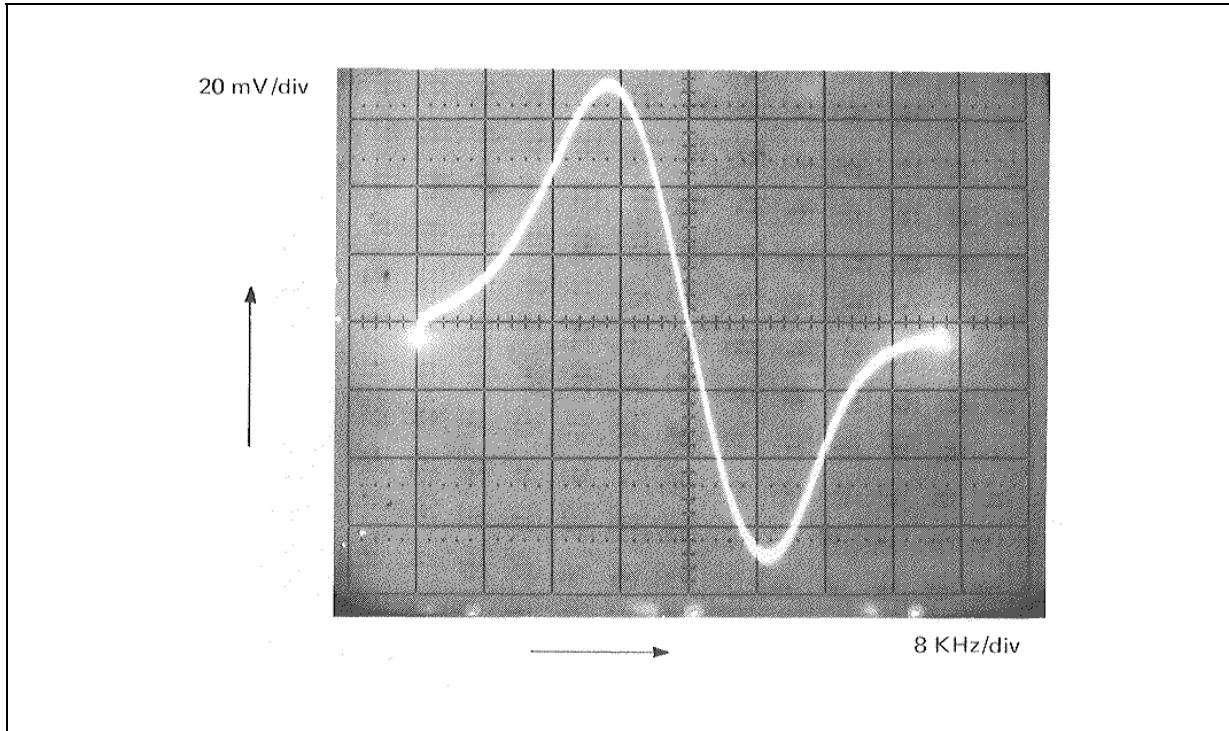
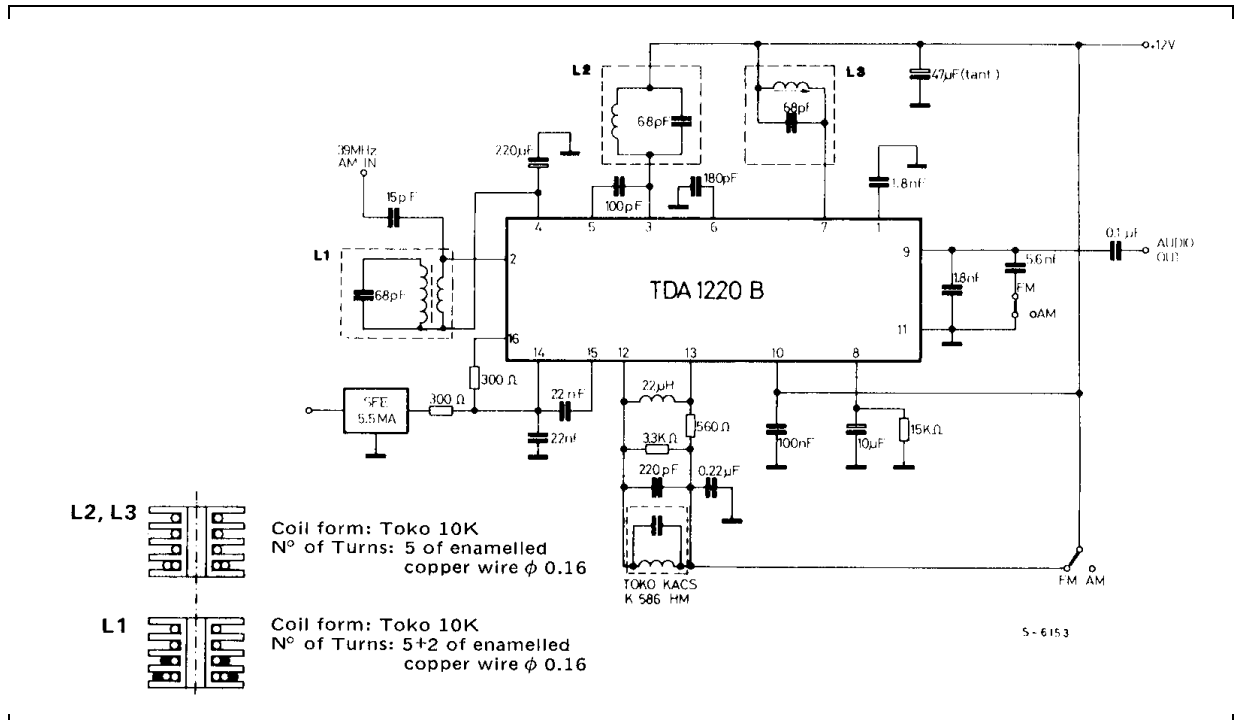

Figure 21. Application in sound channel of multistandard TV or in parallel AM modulated sound channel (AM section only).



TDA1220B

ELECTRICAL CHARACTERISTICS ($V_s = 12V$)

AM Section ($f_o = 39MHz$; $f_m = 15KHz$)

| Parameter | Typ | Unit |
|--|-----|------|
| Audio out ($m = 0.3$) | 60 | mV |
| S/N ($V_i = 100\text{ mV}$; $m = 0.3$) | 37 | dB |
| S/N ($V_i = 1\text{ mV}$; $m = 0.3$) | 55 | dB |
| S/N ($V_i = 10\text{ mV}$; $m = 0.3$) | 56 | dB |
| AGC range ($m = 0.8$, $\Delta V_{out} = 3\text{ dB}$) | 65 | dB |
| Max input signal handling ($m = 0.8$; $d = 5\%$) | 150 | mV |
| - 3dB bandwidth | 600 | KHz |
| Distortion ($V_i = 100\ \mu\text{V}$; $m = 0.3$) | 2 | % |
| ($V_i = 1\text{ mV}$; $m = 0.3$) | 1 | % |
| ($V_i = 10\text{ mV}$; $m = 0.3$) | 0.8 | % |
| ($V_i = 100\ \mu\text{V}$; $m = 0.8$) | 7 | % |
| ($V_i = 1\text{ mV}$; $m = 0.8$) | 5 | % |
| ($V_i = 10\text{ mV}$; $m = 0.8$) | 3 | % |

FM Section ($f_o = 5.5MHz$; $f_m = 1KHz$)

| Parameter | Typ | Unit |
|--|-----|---------------|
| -3dB input limiting voltage ($\Delta f = 25KHz$) | 3 | μV |
| AMR ($\Delta f = +25KHz$; $m = 0.3$; $V_i = 100\ \mu\text{V}$) | 40 | dB |
| ($\Delta f = +25KHz$; $m = 0.3$; $V_i = 1\text{ mV}$) | 58 | dB |
| ($\Delta f = +25KHz$; $m = 0.3$; $V_i = 10\text{ mV}$) | 54 | dB |
| S/N ($\Delta f = \pm 25KHz$; $V_i = 100\ \mu\text{V}$) | 51 | dB |
| S/N ($\Delta f = \pm 25KHz$; $V_i = 1\text{ mV}$) | 70 | dB |
| S/N ($\Delta f = \pm 25KHz$; $V_i = 10\text{ mV}$) | 70 | dB |
| Distortion ($\Delta f = \pm 25KHz$; $V_i = 100\ \mu\text{V}$) | 0.5 | % |
| ($\Delta f = \pm 25KHz$; $V_i = 1\text{ mV}$) | 0.6 | % |
| ($\Delta f = \pm 25KHz$; $V_i = 10\text{ mV}$) | 0.6 | % |
| ($\Delta f = \pm 50KHz$; $V_i = 100\ \mu\text{V}$) | 1 | % |
| ($\Delta f = \pm 50KHz$; $V_i = 1\text{ mV}$) | 1 | % |
| ($\Delta f = \pm 50KHz$; $V_i = 10\text{ mV}$) | 1 | % |
| Recovered audio ($\Delta f = \pm 15KHz$; $V_i = 1\text{ mV}$) Recovered audio can be varied by variation of 3.3K ohm resistor in parallel with the discriminator coil) | 70 | mV |
| Max input signal handling | 1 | V |

Note: AM performance at 39MHz can be improved by mean of a selective preamplifier stage.

DIP16 PACKAGE MECHANICAL DATA

| DIM. | mm | | | inch | | |
|------|------|-------|------|-------|-------|-------|
| | MIN. | TYP. | MAX. | MIN. | TYP. | MAX. |
| a1 | 0.51 | | | 0.020 | | |
| B | 0.77 | | 1.65 | 0.030 | | 0.065 |
| b | | 0.5 | | | 0.020 | |
| b1 | | 0.25 | | | 0.010 | |
| D | | | 20 | | | 0.787 |
| E | | 8.5 | | | 0.335 | |
| e | | 2.54 | | | 0.100 | |
| e3 | | 17.78 | | | 0.700 | |
| F | | | 7.1 | | | 0.280 |
| l | | | 5.1 | | | 0.201 |
| L | | 3.3 | | | 0.130 | |
| Z | | | 1.27 | | | 0.050 |

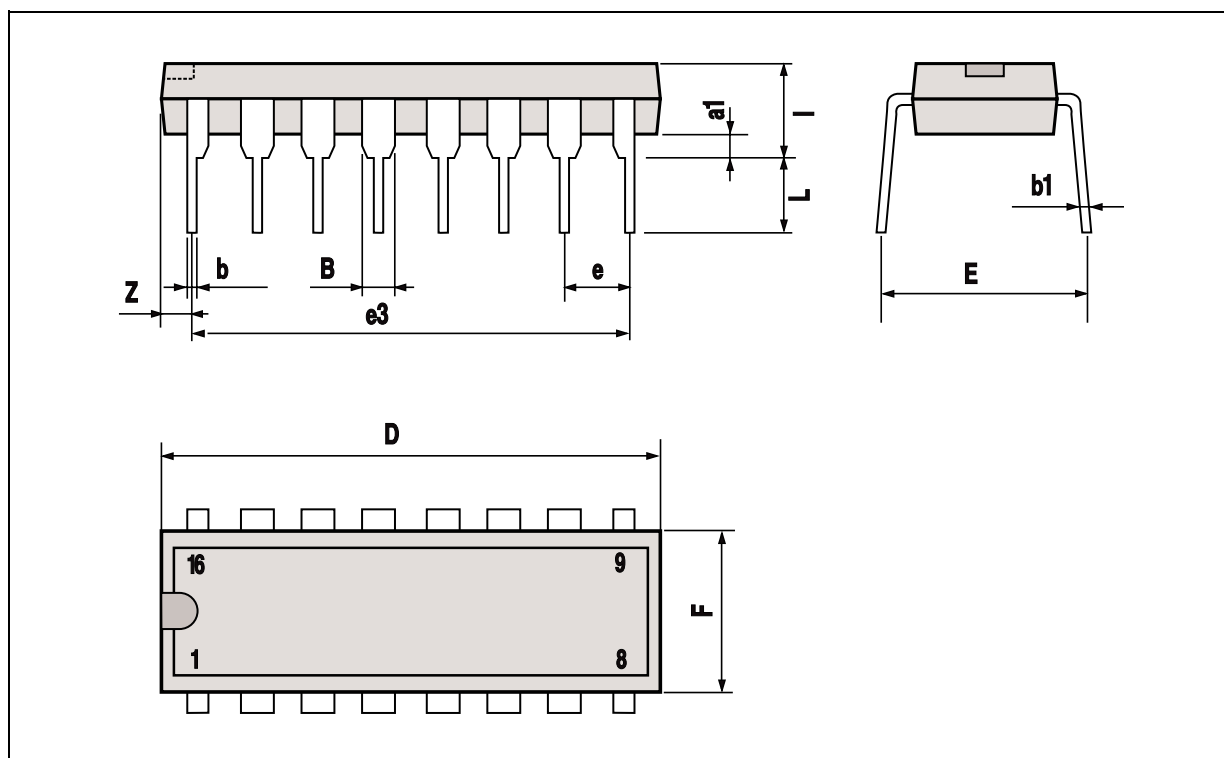

Information furnished is believed to be accurate and reliable. However, SGS-THOMSON Microelectronics assumes no responsibility for the consequences of use of such information nor for any infringement of patents or other rights of third parties which may result from its use. No license is granted by implication or otherwise under any patent or patent rights of SGS-THOMSON Microelectronics. Specifications mentioned in this publication are subject to change without notice. This publication supersedes and replaces all information previously supplied. SGS-THOMSON Microelectronics products are not authorized for use as critical components in life support devices or systems without express written approval of SGS-THOMSON Microelectronics.

© 1994 SGS-THOMSON Microelectronics - All Rights Reserved

SGS-THOMSON Microelectronics GROUP OF COMPANIES

Australia - Brazil - France - Germany - Hong Kong - Italy - Japan - Korea - Malaysia - Malta - Morocco - The Netherlands - Singapore - Spain - Sweden - Switzerland - Taiwan - Thailand - United Kingdom - U.S.A.