

# High-side Power Switch ICs [With Diagnostic Function] SI-5151S

## Features

- Built-in diagnostic function to detect short and open circuiting of loads and output status signals
- Low saturation PNP transistor use
- Allows direct driving using LS-TTL and C-MOS logic levels
- Built-in overcurrent and thermal protection circuits
- Built-in protection against reverse connection of power supply
- TO220 equivalent full-mold package not require insulation mica

## Absolute Maximum Ratings

(Ta = 25°C)

Parameter	Symbol	Ratings	Unit	Conditions
Power supply voltage	V <sub>B</sub>	40	V	
Input terminal voltage	V <sub>IN</sub>	-0.3 to V <sub>B</sub>	V	
DIAG terminal voltage	V <sub>DIAG</sub>	6	V	
Collector-emitter voltage	V <sub>CE</sub>	40	V	
Output current	I <sub>O</sub>	1.8	A	
Power Dissipation	P <sub>D1</sub>	18	W	With infinite heatsink (T <sub>c</sub> = 25°C)
	P <sub>D2</sub>	1.5	W	Stand-alone without heatsink (T <sub>c</sub> = 25°C)
Junction temperature	T <sub>J</sub>	-40 to +125	°C	
Operating temperature	T <sub>OP</sub>	-40 to +100	°C	
Storage temperature	T <sub>stg</sub>	-40 to +125	°C	

## External Dimensions (unit: mm)

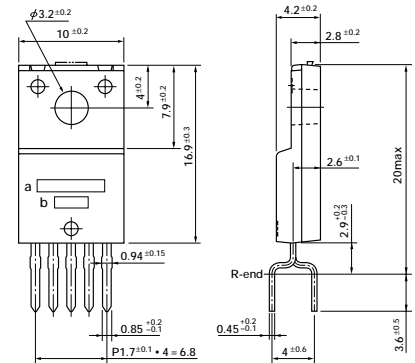

1. GND
  2. V<sub>IN</sub>
  3. V<sub>O</sub>
  4. DIAG
  5. V<sub>B</sub>
- a: Part No.  
b: Lot No.

(Forming No. 1123)

## Electrical Characteristics

(Ta = 25°C unless otherwise specified)

Parameter	Symbol	Ratings			Unit	Conditions
		min	typ	max		
Operating power supply voltage	V <sub>Bopr</sub>	6.0		30	V	
Quiescent circuit current	I <sub>q</sub>		5	12	mA	V <sub>Bopr</sub> = 14V, V <sub>IN</sub> = 0V
Saturation voltage of output transistor	V <sub>CE(sat)</sub>			0.5	V	I <sub>O</sub> ≤ 1.0A, V <sub>Bopr</sub> = 6 to 16V
				1.0	V	I <sub>O</sub> ≤ 1.8A, V <sub>Bopr</sub> = 6 to 16V
Output leak current	I <sub>O, leak</sub>			2	mA	V <sub>CEO</sub> = 16V
Input voltage	Output ON	V <sub>IH</sub>	2.0	V <sub>B</sub>	V	V <sub>Bopr</sub> = 6 to 16V
	Output OFF	V <sub>IL</sub>	-0.3	0.8	V	V <sub>Bopr</sub> = 6 to 16V
Input current	Output ON	I <sub>IH</sub>		1	mA	V <sub>IN</sub> = 5V
	Output OFF	I <sub>IL</sub>	-0.1		mA	V <sub>IN</sub> = 0V
Overcurrent protection starting current	I <sub>S</sub>	1.9			A	V <sub>Bopr</sub> = 14V, V <sub>O</sub> = V <sub>Bopr</sub> - 1.5V
Thermal protection starting temperature	T <sub>TSD</sub>	125	145		°C	
Open load detection resistor	R <sub>open</sub>			30	kΩ	V <sub>Bopr</sub> = 6 to 16V
Output transfer time	T <sub>ON</sub>		8	30	μs	V <sub>Bopr</sub> = 14V, I <sub>O</sub> = 1A
	T <sub>OFF</sub>		15	30	μs	V <sub>Bopr</sub> = 14V, I <sub>O</sub> = 1A
DIAG output voltage	V <sub>DH</sub>	4.5		6	V	V <sub>CC</sub> = 6V
	V <sub>DL</sub>			0.3	V	V <sub>CC</sub> = 6V, I <sub>DD</sub> = 2mA
DIAG output transfer time	T <sub>PLH</sub>			30	μs	V <sub>Bopr</sub> = 14V, I <sub>O</sub> = 1A
	T <sub>PHL</sub>			30	μs	V <sub>Bopr</sub> = 14V, I <sub>O</sub> = 1A
Minimum load inductance	L	1			mH	

Note:

\* The rule of protection against reverse connection of power supply is V<sub>B</sub> = -13V, one minute (all terminals except, V<sub>B</sub> and GND, are open).

## Standard Circuit Diagram

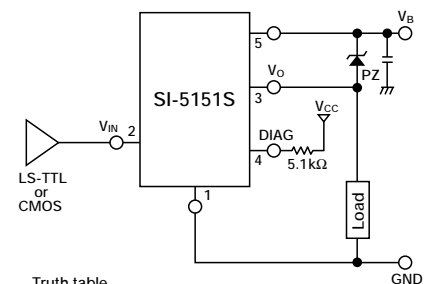

Truth table

V <sub>IN</sub>	V <sub>O</sub>
H	H
L	L

## Diagnostic Function

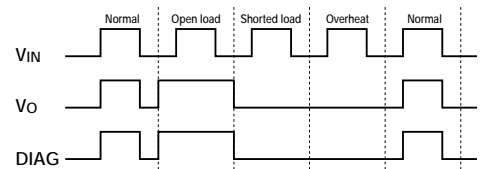

Mode	V <sub>IN</sub>	V <sub>O</sub>	DIAG
Normal	L	L	L
	H	H	H
Open load	L	H	H
	H	H	H
Shorted load	L	L	L
	H	L	L
Overheat	L	L	L
	H	L	L

- DIAG output will be undetermined when a voltage exceeding 25V is applied to V<sub>B</sub> terminal.

## Electrical Characteristics

■ Quiescent Circuit Current

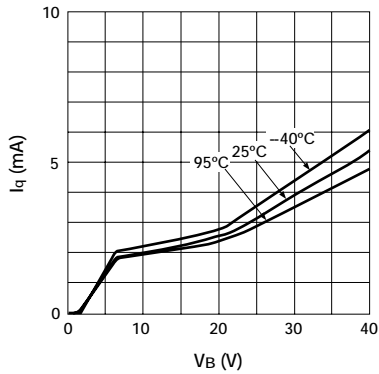

■ Circuit Current

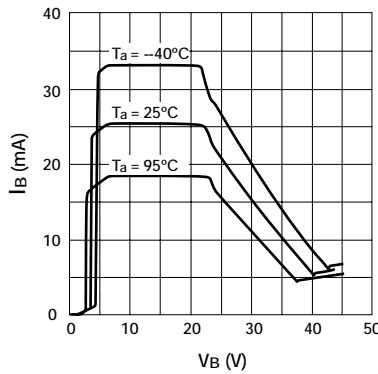

■ Saturation Voltage of Output Transistor

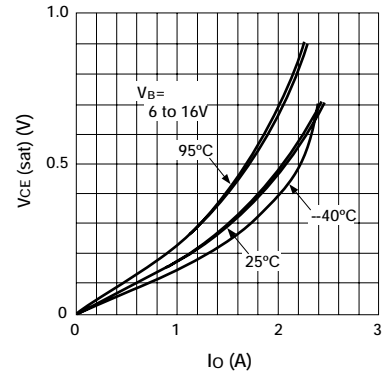

■ Overcurrent Protection Characteristics ( $T_a = -40^\circ\text{C}$ )

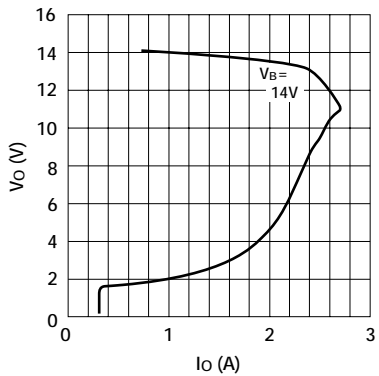

■ Overcurrent Protection Characteristics ( $T_a = 25^\circ\text{C}$ )

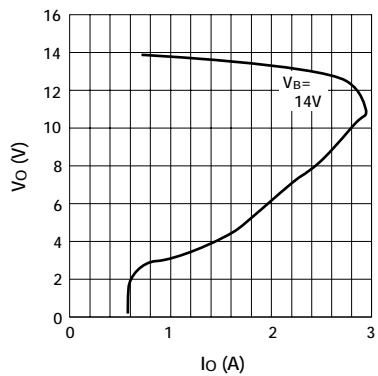

■ Overcurrent Protection Characteristics ( $T_a = 100^\circ\text{C}$ )

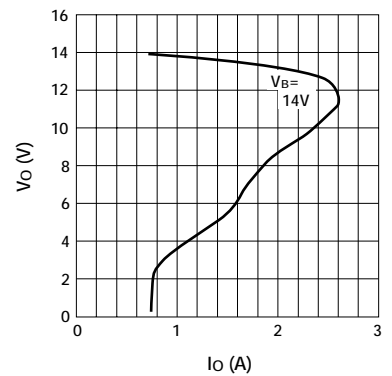

■ Threshold input voltage

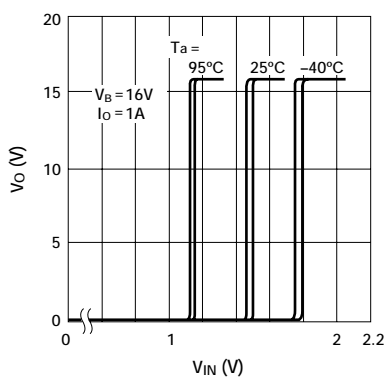

■ Input Current (Output ON)

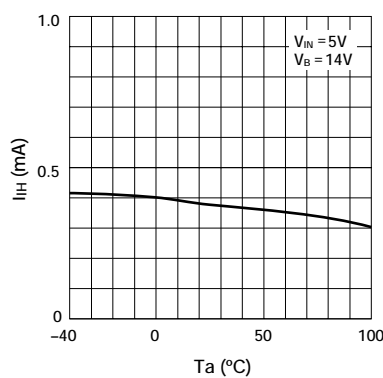

■ Input Current (Output OFF)

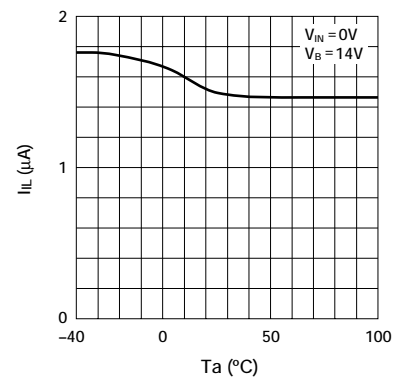

■ Saturation Voltage of DIAG Output

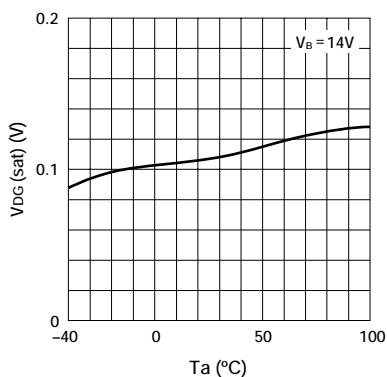

■ Thermal Protection Characteristics

