

TA8424F

3 PHASE HALL MOTOR DRIVER IC

The TA8424F is non switching type 3 Phase Hall Motor Driver IC consisted of FG Amplifier, Regulator for Hall Sensors, control Amplifier and 3 Phase Output Drivers.

FEATURES

- Low Noise (Quasi Sinusoidal Drive), Current Control Motor Driver.
- Low Output Impedance with B Class Push-Pull Driver.
- Output Current Up to 1.2 A.
- Operating Voltage Range : $V_{CC} = 7\sim 17$ V
- Built-in Thermal Shutdown Circuit, FG Amplifier and Regulator.
- 2 Brake Modes Available (Short Brake and Dumping Brake).
- Build in regulator for Hall Sensors.

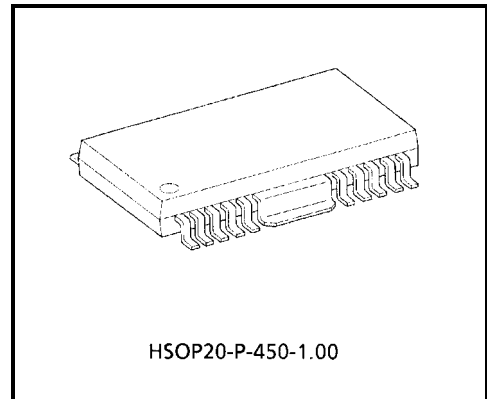

Weight : 0.79 g (Typ.)

BLOCK DIAGRAM

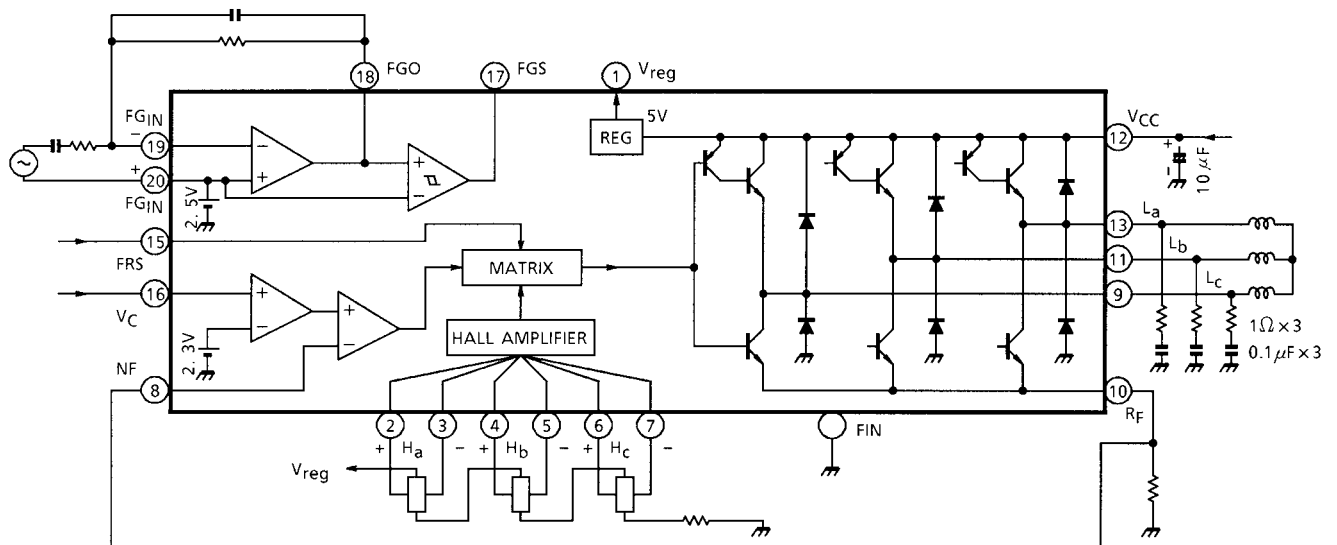

PIN FUNCTION

PIN No.	SYMBOL	FUNCTIONAL DESCRIPTION
1	V _{reg}	Internal power supply output terminal.
2	H _a ⁺	a-phase Hall-Amp positive input terminal.
3	H _a ⁻	a-phase Hall-Amp negative input terminal.
4	H _b ⁺	b-phase Hall-Amp positive input terminal.
5	H _b ⁻	b-phase Hall-Amp negative input terminal.
6	H _c ⁺	c-phase Hall-Amp positive input terminal.
7	H _c ⁻	c-phase Hall-Amp negative input terminal.
8	NF	Feedback resistance connection terminal.
9	L _c	c-phase drive output terminal.
10	R _F	Output current detection terminal.
11	L _b	b-phase drive output terminal.
12	V _{CC}	Power supply input terminal.
13	L _a	a-phase drive output terminal.
14	N.C.	Non connection.
15	FRS	Forward / Reverse control terminal.
16	V _C	Control signal input terminal.
17	FGS	Hysteresis Amp. output terminal.
18	FGO	FG Amp. output terminal.
19	FG _{IN} ⁻	FG Amp. negative input terminal.
20	FG _{IN} ⁺	FG Amp. positive input terminal.
	FIN	GND terminal.

OPERATING MODE

MODE	FRS	V_C	OUTPUT
Forward	L	$V_C > 2.3\text{ V}$	$L_a = H_a - H_b$ $L_b = H_b - H_c$ $L_c = H_c - H_a$
Reverse	H	$V_C > 2.3\text{ V}$	$L_a = -(H_a - H_b)$ $L_b = -(H_b - H_c)$ $L_c = -(H_c - H_a)$
Stand-By	M	—	Center (Note)
Brake	—	$V_C < 2.3\text{ V}$	Center (Note)

Note: Low Impedance

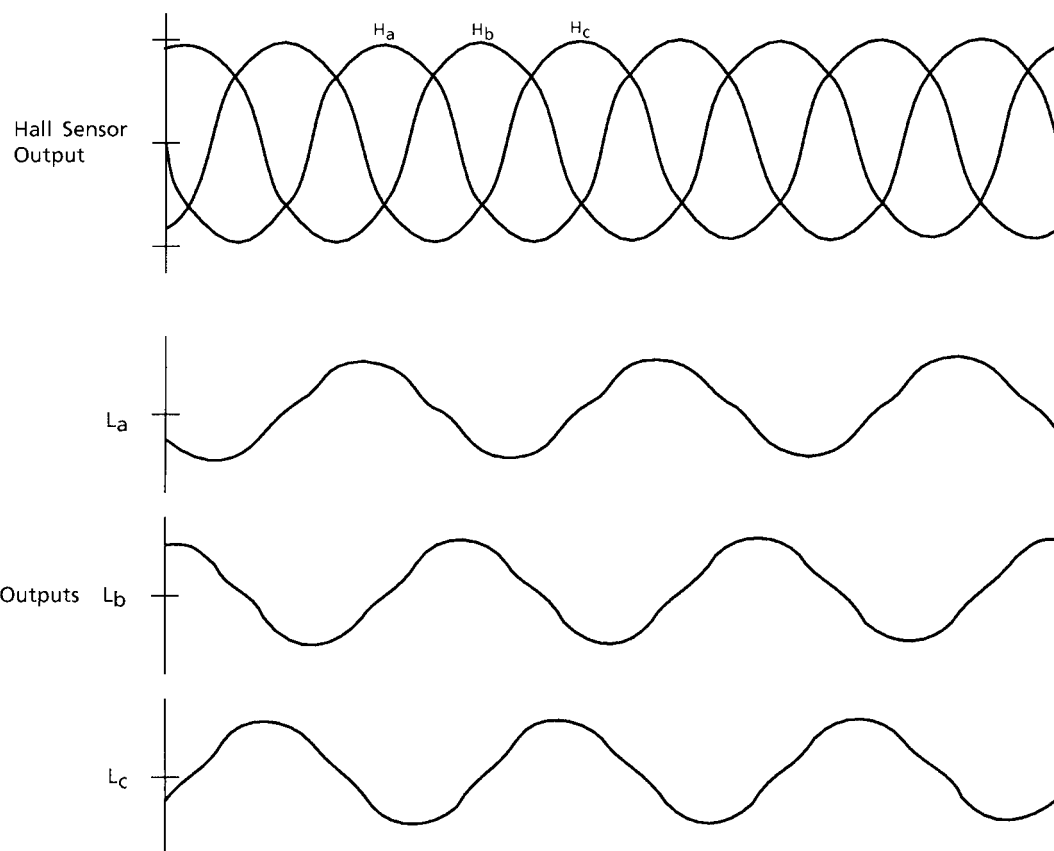

1. Control Gain (G_{VCO})

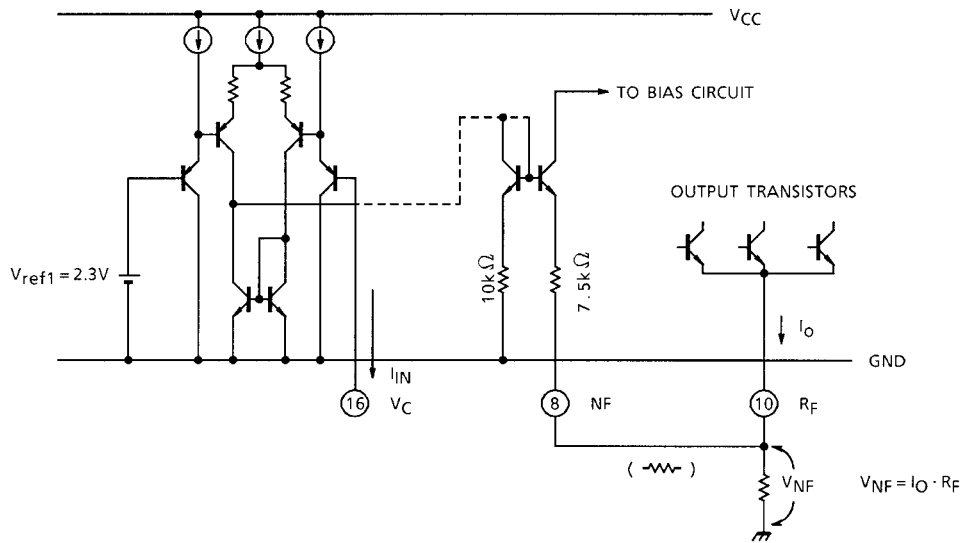

Negative Feedback is looped by R_F and connected its line to pin (8).
 Feedback Voltage V_{NF} is generated by R_F and Output Current I_O .
 It is possible to decrease the feedback by connecting a resistor between pin (10) and pin (8).
 Input current of V_C (I_{IN}) vs V_C characteristic is shown below.

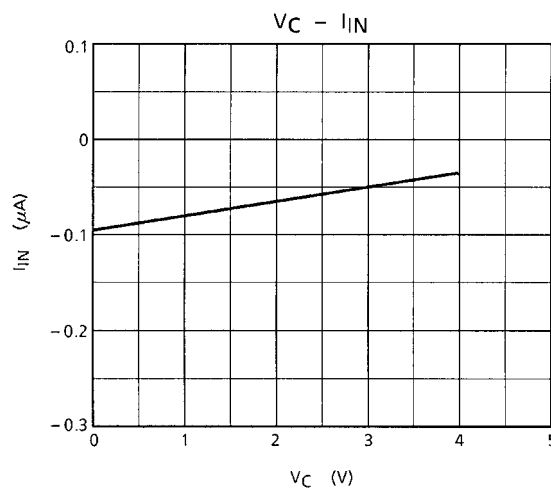

2. FG Amplifier and Hysteresis Amplifier

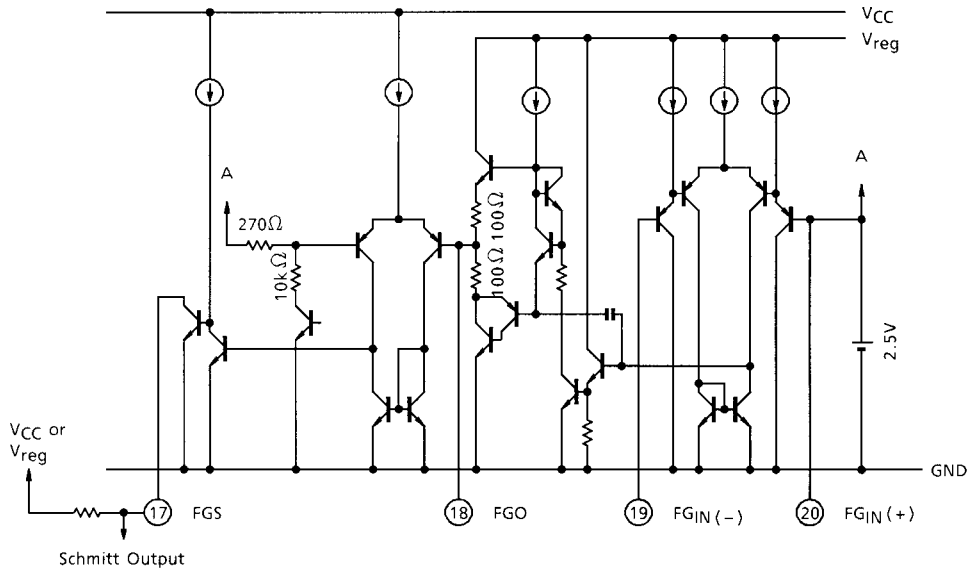

2.5 V of Internal Reference is equipped with FG Amplifier. FG signal is fed into FG_{IN} + and FG_{IN} - inputs with differential mode and outputs to FGO (Pin (18)). Amplified FG signal is wave shaped by Hysteresis Amplifier in following stage and outputs a wave shaped signal to FGS (Pin (17)).

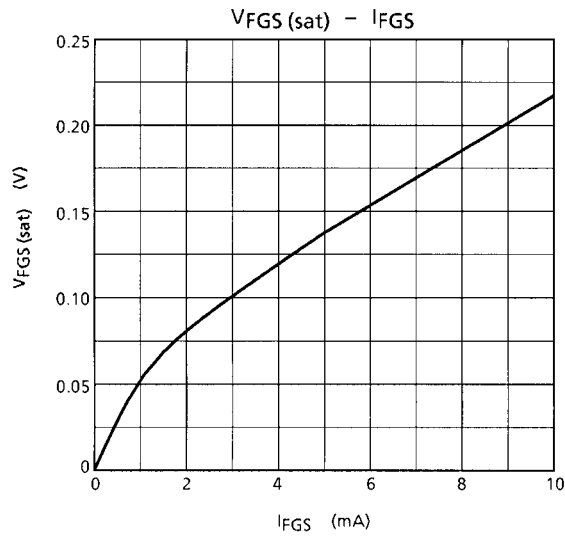

3. Regulator (V_{reg})

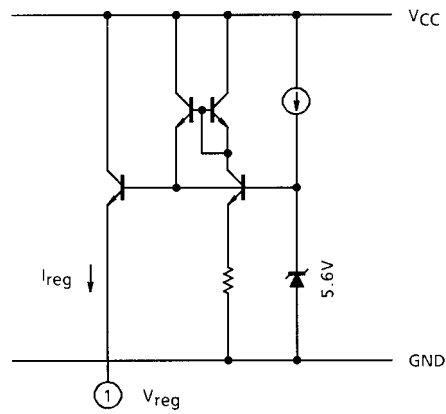

Internal regulator outputs 5 V and this current capability is up to 30 mA. V_{CC} vs V_{reg} characteristic is shown below.

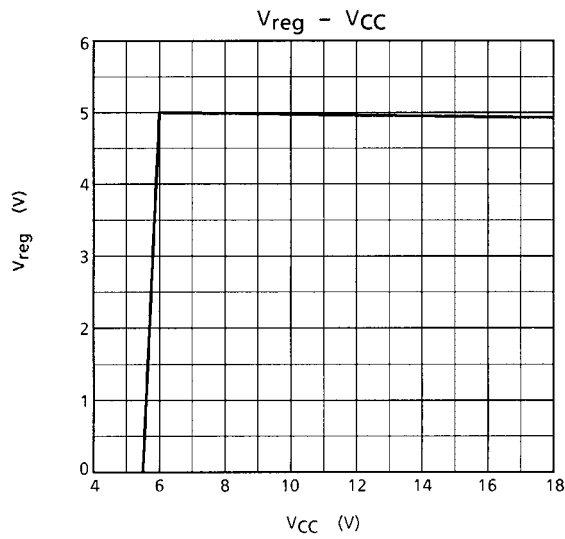

4. FRS input (Rotation direction and stop control)

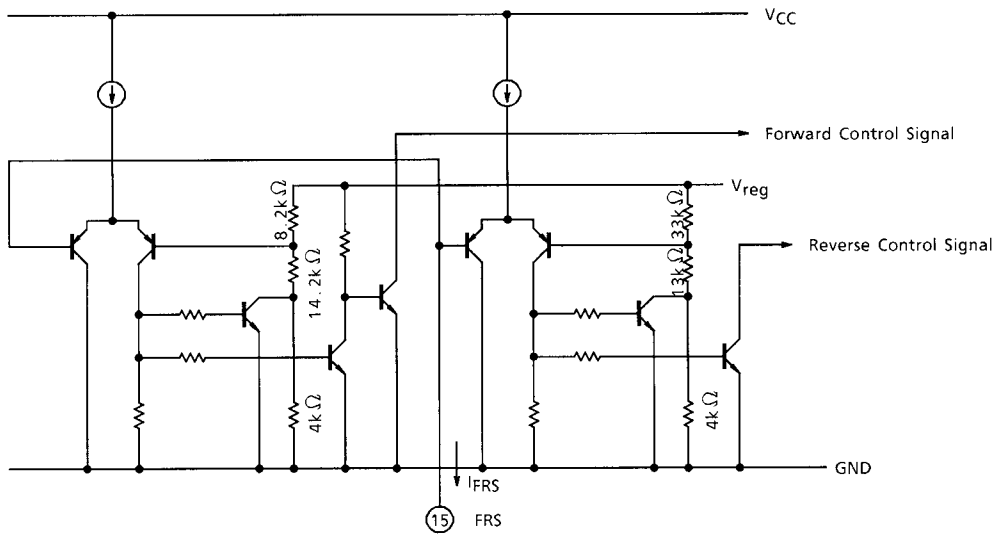

FRS input is a control terminal of Motor Rotation Direction and Stop.
 V_{FRS} vs I_{FRS} characteristic is shown below.

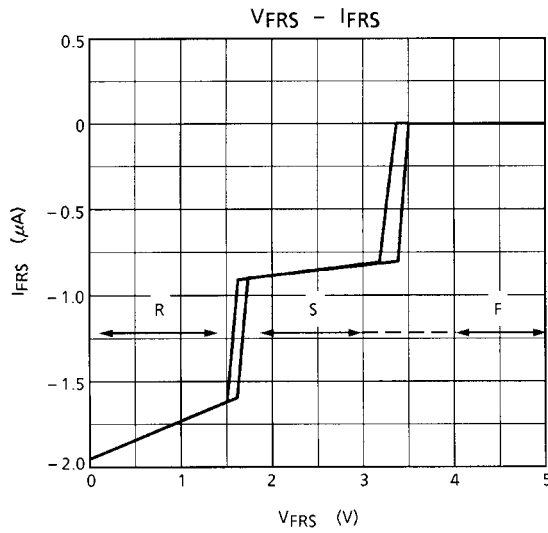

MAXIMUM RATINGS (Ta = 25°C)

CHARACTERISTIC	SYMBOL	RATING	UNIT
Supply Voltage	V _{CC}	18	V
Output Current (Average)	I _O (MAX.)	1.2	A
FG Output Current	I _{FGO}	12	mA
	I _{FGS}	14	
Power Dissipation	P _D	1.0 (Note 1)	W
		3.2 (Note 2)	
		5.8 (Note 3)	
Operating Temperature	T _{opr}	-30~75	°C
Storage Temperature	T _{stg}	-55~150	°C

Note 1: No Heat Sink

Note 2: 50 × 50 × 1mm Fe board, Mounting

Note 3: T_c = 75°C

ELECTRICAL CHARACTERISTICS (V_{CC} = 12 V, Ta = 25°C)

CHARACTERISTIC		SYMBOL	TEST CIRCUIT	TEST CONDITION	MIN	TYP.	MAX	UNIT
Supply Current		I _{CC1}	—	Output open, FRS = 2.5 V	—	12.5	25	mA
		I _{CC2}	—	Output open, FRS = GND	—	14	25	
		I _{CC3}	—	Output open, FRS = 5 V	—	14	25	
Rotation Control Circuit	Control Gain (V _C → Out)	G _{VCO}	—	V _{CC} = 12 V, V _H = 50 mV _{p-p}	7.5	13	18	dB
	Input Current (V _C)	I _{CIN}	—	V _C = GND (Sink current)	—	0.2	5	μA
	Internal Reference-1	V _{ref 1}	—	—	2.15	2.30	2.45	V
Position Sensing Circuit	Common Mode Range	CMR _H	—	—	1.5	—	5	V
	Input Current	I _H	—	V _{IH} = 2.5 V	—	0.2	3	μA
	Voltage Gain (Each Hall Input to OUT)	G _{VHO}	—	V _C = 5 V, V _{CC} = 12 V	40	47	51	dB
Output Driver	Upper Side Saturation	V _{sat (U)}	—	I _O = 1.0 A	—	1.2	1.9	V
	Lower Side Saturation	V _{sat (L)}	—	I _O = 1.0 A	—	0.7	1.5	
	Quiescent Voltage	V _{OS}	—	V _C = 1.0 V	5.0	5.5	7.0	V
	Quiescent Voltage Difference	V _{OOFF}	—	Each output to output	—	25	50	mV
FG Amp	Open Loop Gain	G _{VFG}	—	f _{FG} = 1 kHz	—	70	—	dB
	Band Width	f _{FG}	—	—	DC	—	50	kHz
	Output Voltage Swing	V _{FGO}	—	I _{FGO} = 5 mA	1.0	2.1	4	V
	FGS Saturation	V _{sat (FGS)}	—	I _{FGS} = 4 mA	—	0.15	0.25	V
	Internal Reference-2	V _{ref 2}	—	—	2.1	2.5	2.9	V
	Hysteresis Voltage	V _{HYS}	—	—	—	100	250	mV
Rotation Direction Control	FWD	Operating Voltage	V _{FWD}	—	4.0	—	V _{CC}	V
	STOP	Operating Voltage	V _{STOP}	—	1.9	—	3.1	V
	REVERSE	Operating Voltage	V _{REV}	—	0	—	1.3	V
Regulator Output Voltage		V _{REG}	—	I _H = 10 mA	4.7	5.1	5.5	V
Thermal Shutdown Operating Temperature		T _{SD}	—	—	150	—	—	°C

Output Amplifier Saturation Voltage Characteristics

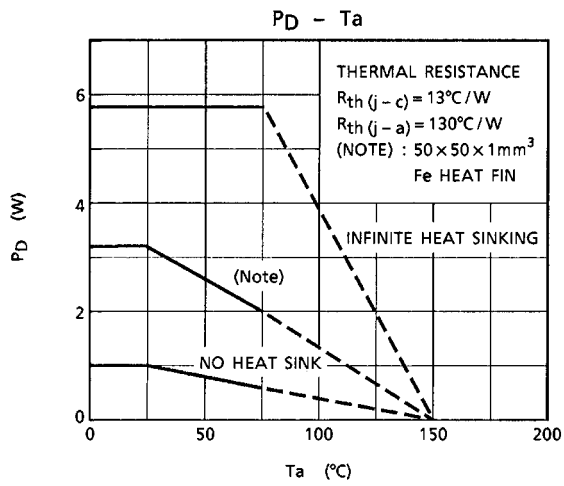
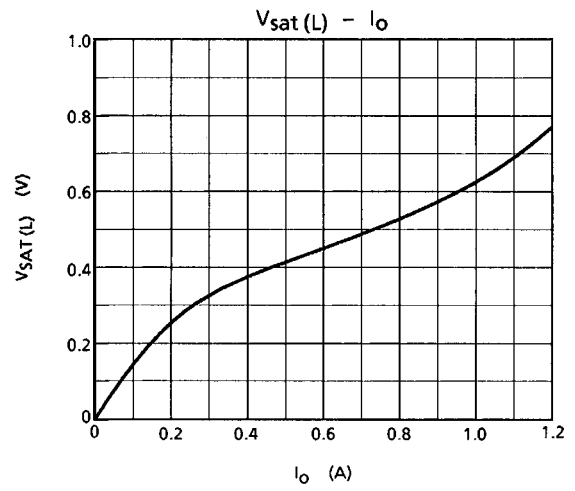
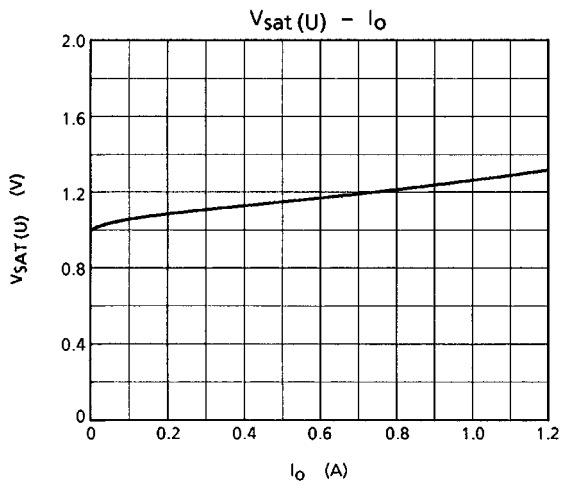

APPLICATION CIRCUIT

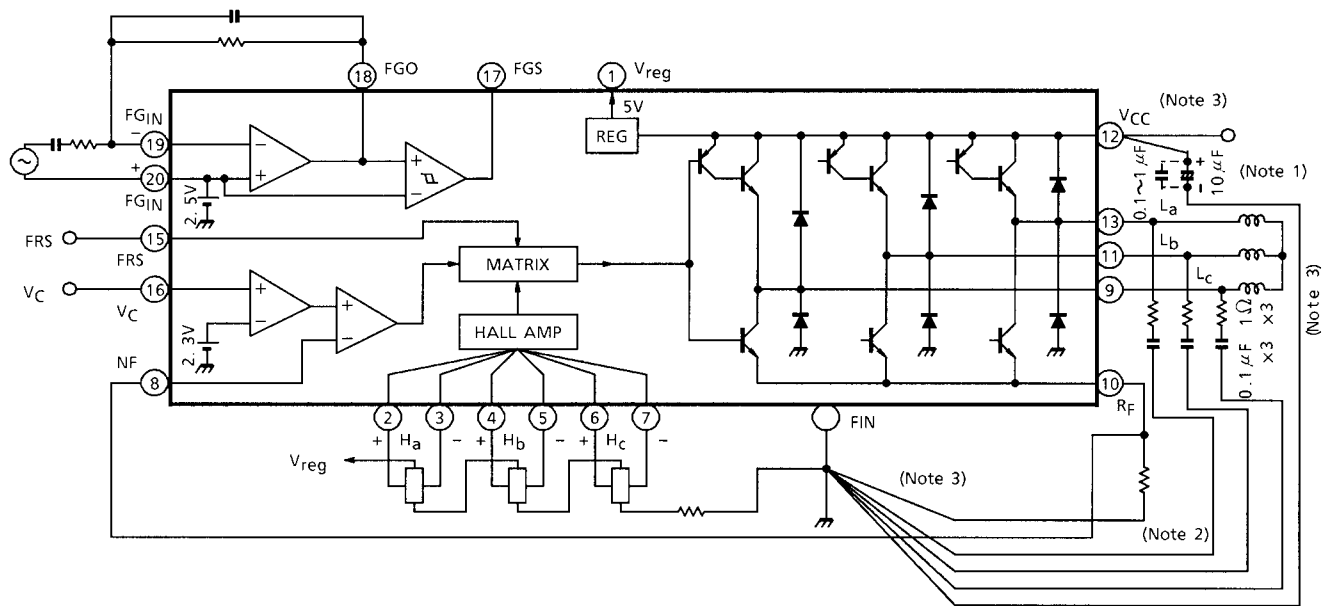

Note 1: Connect if required (0.1~1 μF)

Note 2: Care should be taken not to have common impedance between R_F GND Line and other small signal lines for stable operations (especially for Hall Sensor GND line).

Note 3: Utmost care is necessary in the design of the output line, V_{CC} and GND line since IC may be destroyed due to short-circuit between outputs, air contamination fault, or fault by improper grounding.

PACKAGE DIMENSIONS

HSOP20-P-450-1.00

Unit : mm

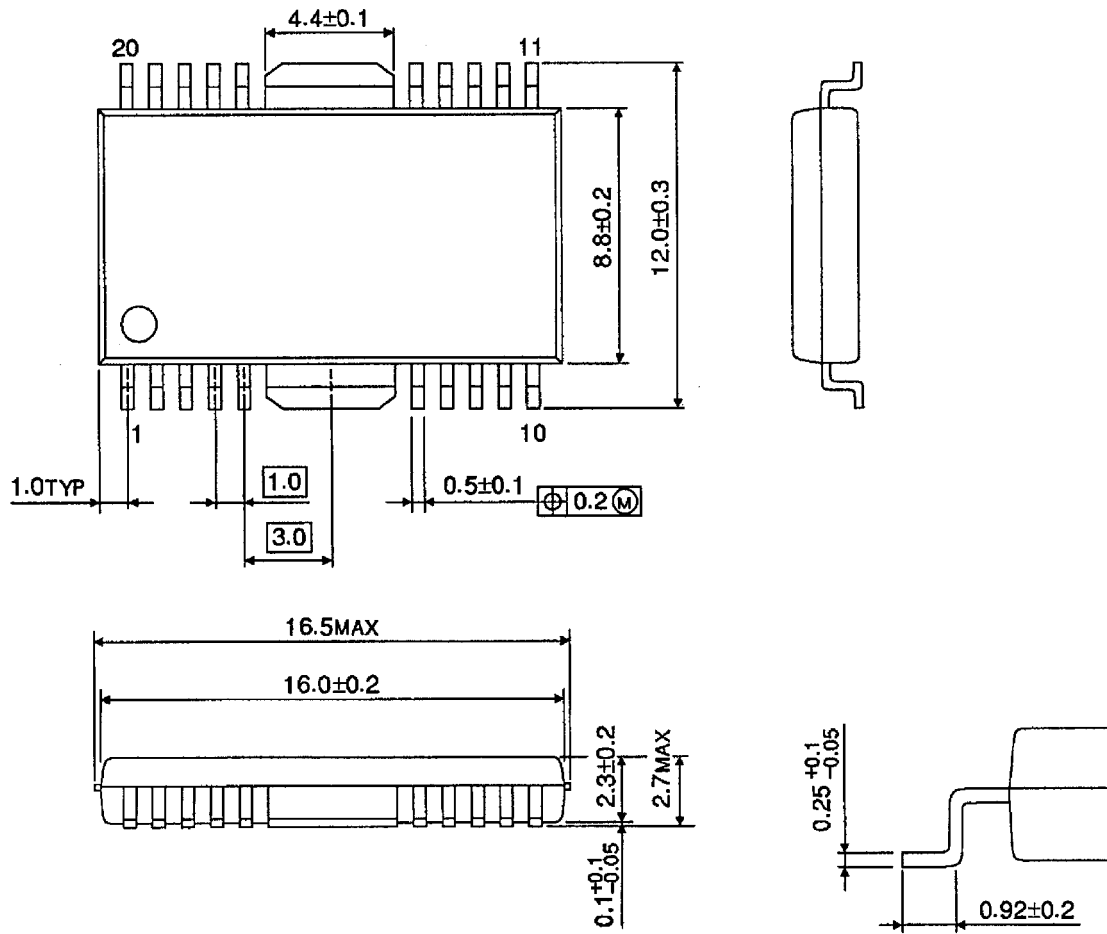

Weight : 0.79 g (Typ.)

RESTRICTIONS ON PRODUCT USE

000707EBA

- TOSHIBA is continually working to improve the quality and reliability of its products. Nevertheless, semiconductor devices in general can malfunction or fail due to their inherent electrical sensitivity and vulnerability to physical stress. It is the responsibility of the buyer, when utilizing TOSHIBA products, to comply with the standards of safety in making a safe design for the entire system, and to avoid situations in which a malfunction or failure of such TOSHIBA products could cause loss of human life, bodily injury or damage to property.
In developing your designs, please ensure that TOSHIBA products are used within specified operating ranges as set forth in the most recent TOSHIBA products specifications. Also, please keep in mind the precautions and conditions set forth in the "Handling Guide for Semiconductor Devices," or "TOSHIBA Semiconductor Reliability Handbook" etc..
- The TOSHIBA products listed in this document are intended for usage in general electronics applications (computer, personal equipment, office equipment, measuring equipment, industrial robotics, domestic appliances, etc.). These TOSHIBA products are neither intended nor warranted for usage in equipment that requires extraordinarily high quality and/or reliability or a malfunction or failure of which may cause loss of human life or bodily injury ("Unintended Usage"). Unintended Usage include atomic energy control instruments, airplane or spaceship instruments, transportation instruments, traffic signal instruments, combustion control instruments, medical instruments, all types of safety devices, etc.. Unintended Usage of TOSHIBA products listed in this document shall be made at the customer's own risk.
- The products described in this document are subject to the foreign exchange and foreign trade laws.
- The information contained herein is presented only as a guide for the applications of our products. No responsibility is assumed by TOSHIBA CORPORATION for any infringements of intellectual property or other rights of the third parties which may result from its use. No license is granted by implication or otherwise under any intellectual property or other rights of TOSHIBA CORPORATION or others.
- The information contained herein is subject to change without notice.