

TOSHIBA Bipolar Linear Integrated Circuit Silicon Monolithic

TA8167N

3V AM / FM 1 CHP Tuner IC

TA8167N is the AM / FM 1 chip tuner IC, which is designed for portable radios and 3V headphone radios.

Features

- Built-in
FM F / E, AM / FM IF and FM MPX
- AM detector coil and IF coupling condenser are not needed.
- S curve characteristics of FM detection output is reverse characteristic.
- The FM local oscillation voltage is set up low relatively for measures against FM radiation.
- Operating supply voltage range
 $V_{CC} = 1.8 \sim 7.0V$ ($T_a = 25^\circ C$)

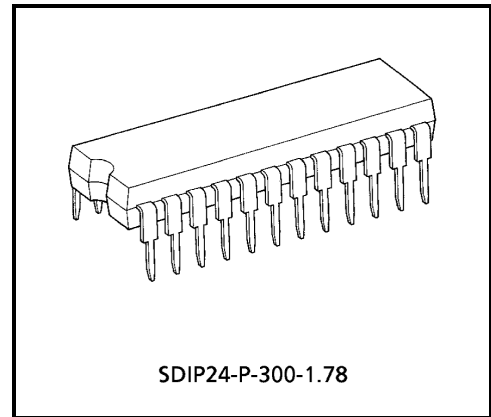

Weight: 1.2g (typ.)

Block Diagram

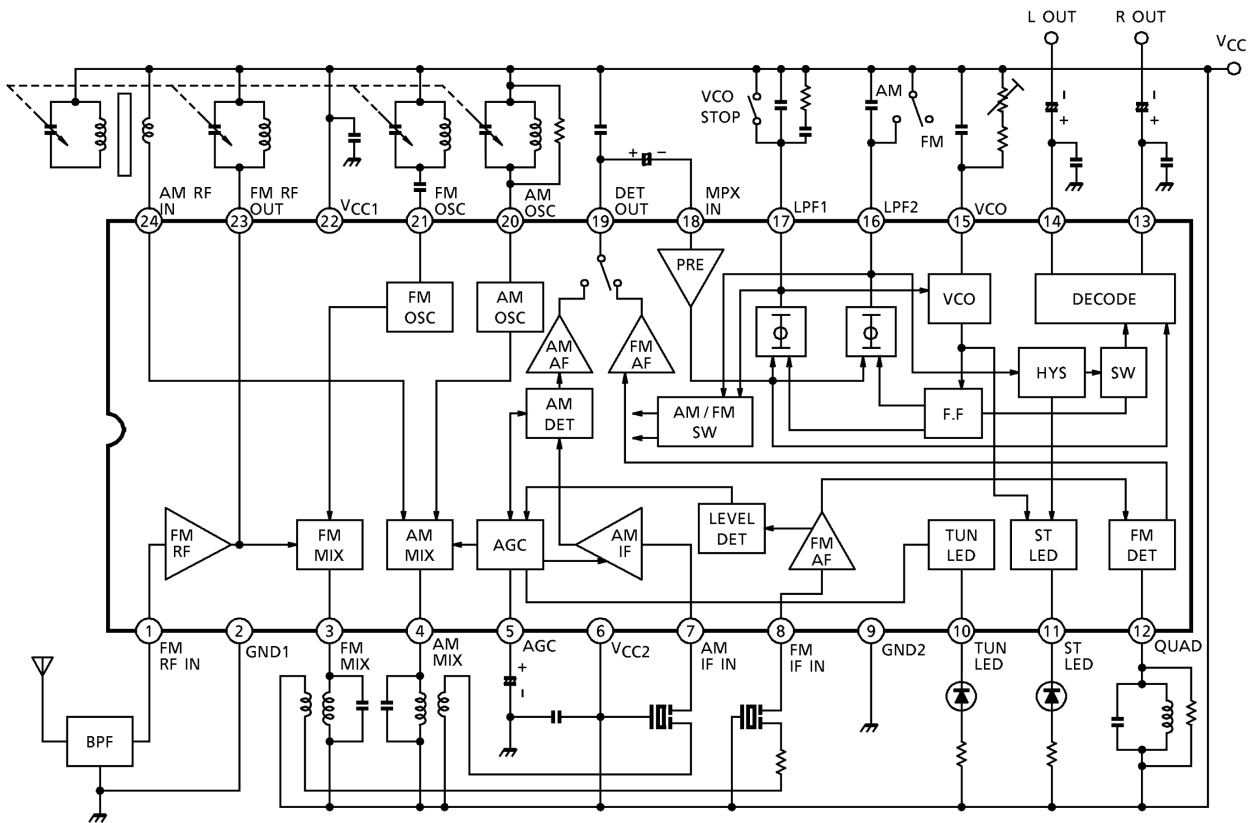

Explanation Of Terminals

Pin No.	Symbol	Internal Circuit	DC Voltage (V) (at no signal)	
			AM	FM
1	FM-RF IN		0	0.7
2	GND1 (GND for RF stage)	—	0	0
3	FM MIX		3.0	3.0
4	AM MIX		3.0	3.0
5	AGC (AM AGC)		0	0
6	VCC2 (VCC for IF / MPX stage)	—	3.0	3.0
7	AM IF IN		3.0	3.0
8	FM IF IN		3.0	3.0

Pin No.	Symbol	Internal Circuit	DC Voltage (V) (at no signal)	
			AM	FM
9	GND2 (GND for IF / MPX stage)	—	0	0
10	Tun LED (tuning LED)		—	—
11	ST LED (stereo LED)		—	—
12	QUAD (FM QUAD, detector)		3.0	3.0
13 14	R-OUT (R-ch output) L-OUT (L-ch output)		1.0	1.0
15	VCO		2.5	2.5 (VCO stop mode)
16	LPF2 • LPF terminal for synchronous detector • Bias terminal for AM / FM SW circuit V ₁₆ = V _{CC} → AM (VCO stop) V ₁₆ = OPEN → FM		3.0	2.2 (VCO stop mode 2.7)
17	LPF1 • LPF terminal for phase detector • VCO stop terminal V ₁₇ = V _{CC} → VCO stop		2.7	2.2

Pin No.	Symbol	Internal Circuit	DC Voltage (V) (at no signal)	
			AM	FM
18	MPX IN		0.7	0.7
19	DET OUT		1.5	1.2
20	AM OSC		3.0	3.0
21	FM OSC		3.0	3.0
22	V _{CCL} (V _{CC} for RF stage)	—	3.0	3.0
23	FM RF OUT	Cf. pin(1)	3.0	3.0
24	AM RF IN		3.0	3.0

Maximum Ratings (Ta = 25°C)

Characteristic	Symbol	Rating	Unit
Supply voltage	V _{CC}	8	V
LED current	I _{LED}	10	mA
LED voltage	V _{LED}	8	V
Power dissipation	P _D (Note)	1200	mW
Operating temperature	T _{opr}	-25~75	°C
Storage temperature	T _{stg}	-55~150	°C

(Note) Derated above Ta = 25°C in the proportion of 9.6mW / °C.

Electrical Characteristics

Unless Otherwise Specified, Ta = 25°C, V_{CC} = 3V, F / E: f = 83MHz, f_m = 1kHz
 FM IF: f = 10.7MHz, Δf = ±22.5kHz, f_m = 1kHz
 AM: f = 1MHz, MOD = 30%, f_m = 1kHz
 MPX: f_m = 1kHz

Characteristic		Symbol	Test Circuit	Test Condition	Min.	Typ.	Max.	Unit
Supply current		I _{CC} (FM)	1	V _{in} = 0, FM mode	—	13.2	20.0	mA
		I _{CC} (AM)	1	V _{in} = 0, AM mode	—	8.4	13.5	
F / E	Input limiting voltage	V _{in} (lim)	1	-3dB limiting	—	10.0	—	dBμV EMF
	Local OSC voltage	V _{OSC}	2	f _{OSC} = 72.3MHz	—	70	—	mV _{rms}
FM IF	Input limiting voltage	V _{in} (lim) IF	1	-3dB limiting	40	46	53	dBμV EMF
	Recovered output voltage	V _{OD}	1	V _{in} = 80dBμV EMF	55	80	110	mV _{rms}
	Signal to noise ratio	S / N	1	V _{in} = 80dBμV EMF	—	70	—	dB
	Total harmonic distortion	THD	1	V _{in} = 80dBμV EMF	—	0.4	—	%
	AM rejection ratio	AMR	1	V _{in} = 80dBμV EMF	—	32	—	dB
	Lamp on sensitivity	V _L	1	I _L = 1mA	45	51	56	dBμV EMF
AM	Gain	G _V	1	V _{in} = 26dBμV EMF	40	70	110	mV _{rms}
	Recovered output voltage	V _{OD}	1	V _{in} = 60dBμV EMF	55	80	110	mV _{rms}
	Signal to noise ratio	S / N	1	V _{in} = 60dBμV EMF	—	42	—	dB
	Total harmonic distortion	THD	1	V _{in} = 60dBμV EMF	—	1.0	—	%
	Lamp on sensitivity	V _L	1	I _L = 1mA	20	25	30	dBμV EMF
Pin(19) output resistance	R ₁₉	—	FM mode	—	0.75	—	kΩ	
			AM mode	—	12.5	—		

Characteristic		Symbol	Test Circuit	Test Condition	Min.	Typ.	Max.	Unit	
MPX	Input resistance	R_{IN}	—	—	—	24	—	k Ω	
	Output resistance	R_{OUT}	—	—	—	5	—	k Ω	
	Max. Composite signal input voltage	$V_{in\ max}$ (stereo)	1	L + R = 90%, P = 10%, $f_m = 1\text{kHz}$, THD = 3%	—	350	—	mV $_{rms}$	
	Separation	Sep	1	L + R = 135mV $_{rms}$ P = 15mV $_{rms}$	$f_m = 100\text{Hz}$	—	42	—	dB
					$f_m = 1\text{kHz}$	35	42	—	
					$f_m = 10\text{kHz}$	—	42	—	
	Total harmonic distortion	Monaural	THD (monaural)	1	$V_{in} = 150\text{mV}_{rms}$	—	0.2	—	%
		Stereo	THD (stereo)		L + R = 135mV $_{rms}$, P = 15mV $_{rms}$	—	0.2	—	
	Voltage gain		G_V (MPX)	1	$V_{in} = 150\text{mV}_{rms}$	-5	-3	-1	dB
	Channel balance		C.B.	1	$V_{in} = 150\text{mV}_{rms}$	-2	0	2	dB
	Stereo lamp sensitivity	ON	V_L (ON)	1	Pilot input	—	8	16	mV $_{rms}$
		OFF	V_L (OFF)			2	6	—	
Stereo lamp hysteresis		V_H	1	To LED turn off from LED turn on	—	2	—	mV $_{rms}$	
Capture range		C.R.	1	P = 15mV $_{rms}$	—	± 3	—	%	
Signal to noise ratio		S / N	1	—	—	70	—	dB	

Test Circuit 1

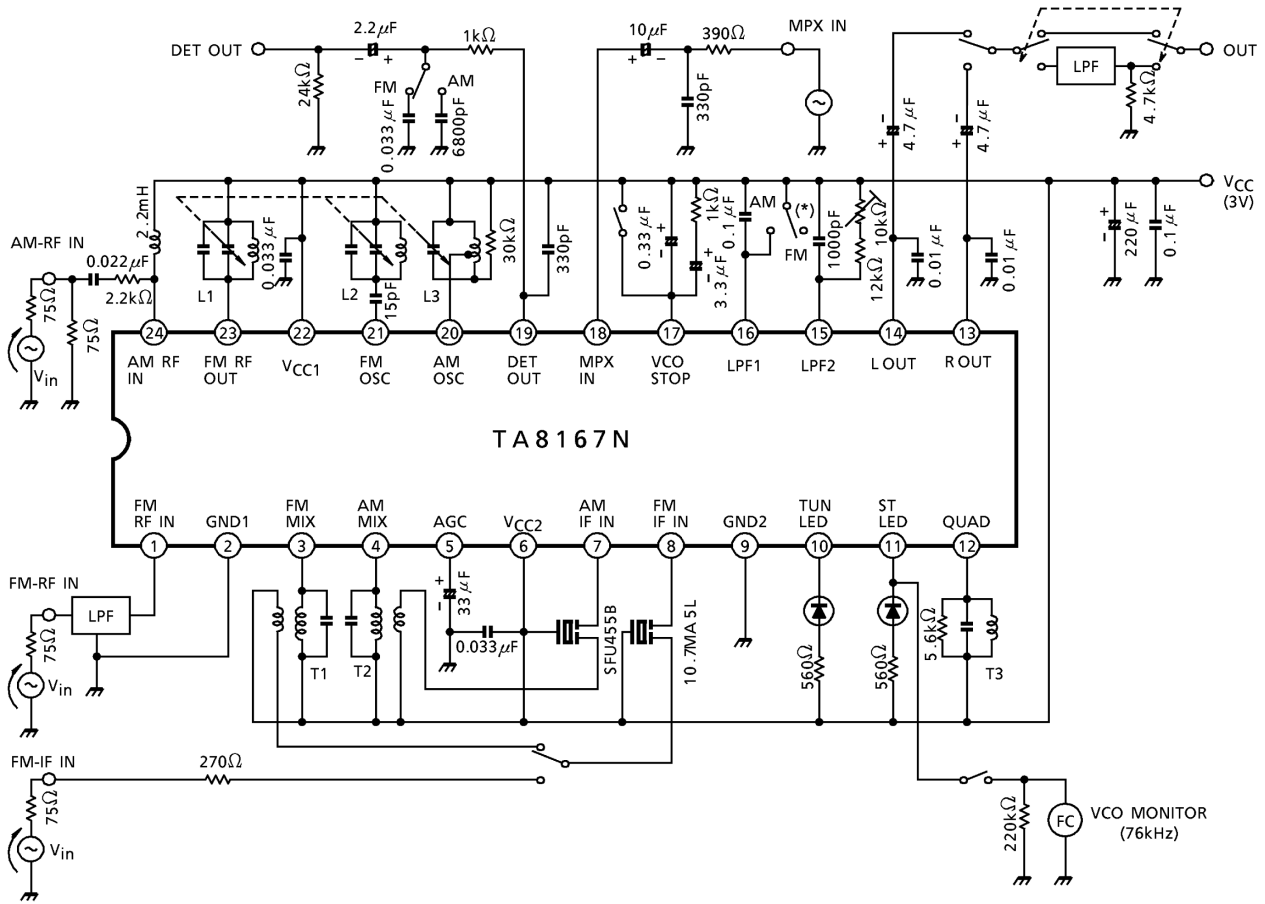

(*) Polyester film condenser

Using other types of condensers, there are some cases that the MPX dose not do normal stereo action at high temperature or low temperature.

Test Circuit 2

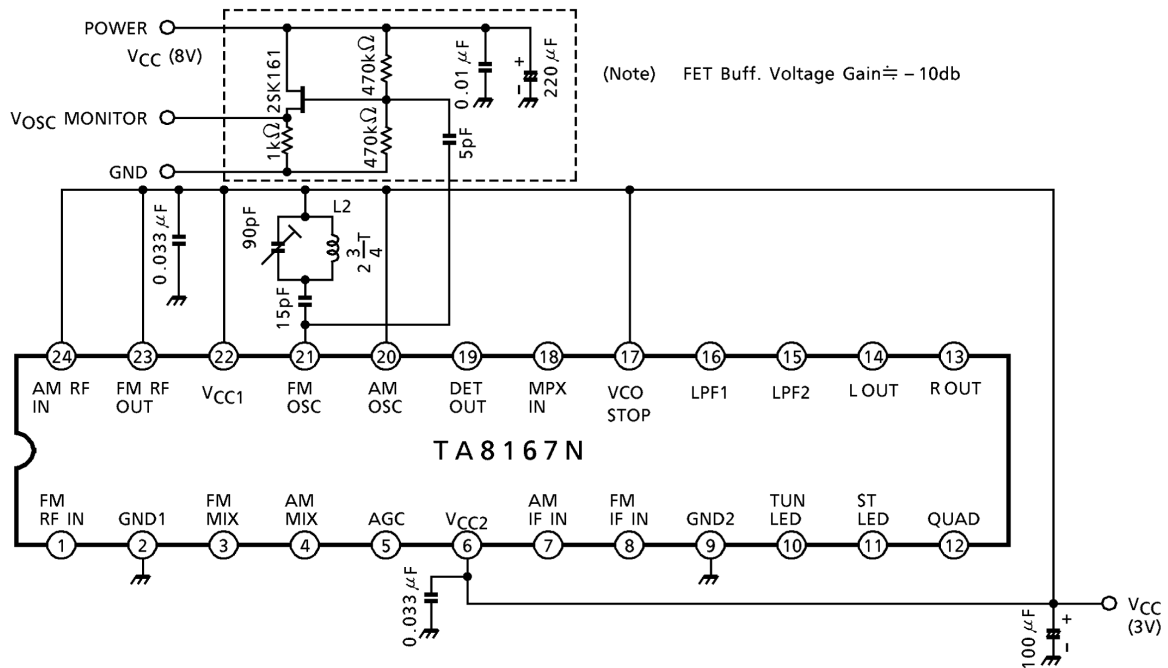

Coil Data

Coil No.	Test Freq. (Hz)	L (μH)	C ₀ (pF)	Q ₀	Turns					Wire (mmφ)	Reference
					1-2	2-3	1-3	1-4	4-6		
L ₁ FM RF	100M	—	—	100	—	—	—	2 ¹ / ₂	—	0.5 UEW	(S) 53T-037-202
L ₂ FM OSC	100M	—	—	100	—	—	2 ³ / ₄	—	—	0.5 UEW	(S) 0258-244
L ₃ AM OSC	796k	288	—	115	13	73	—	—	—	0.08 UEW	(S) 4147-1356-038
T ₁ FM mix	10.7M	—	75	100	—	—	13	—	2	0.1 UEW	(S) 2153-414-041
T ₂ AM mix	455k	—	180	120	—	—	180	—	15	0.08 UEW	(S) 2150-2162-165
T ₃ FM DET	10.7M	—	47	165	—	—	16	—	—	0.09 UEW	(S) 2153-4095-122

(S) : SUMIDA ELECTRIC CO., LTD.

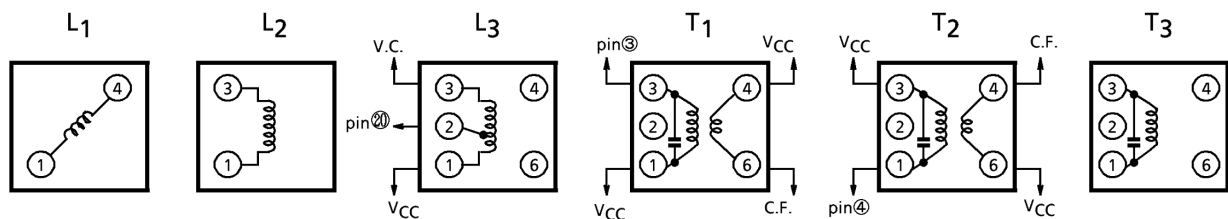

Hint On Use Of TA8167N

○External parts of MPX VCO

(1) Temperature characteristic of MPX VCO free-run frequency.

The temperature characteristic of MPX VCO is shown in the diagram as below.

Select one with a better temperature characteristic (C, R and VR.) in use. We recommend,

C : Polyester film

R, VR: Carbon film

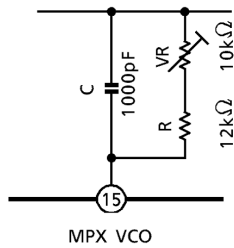
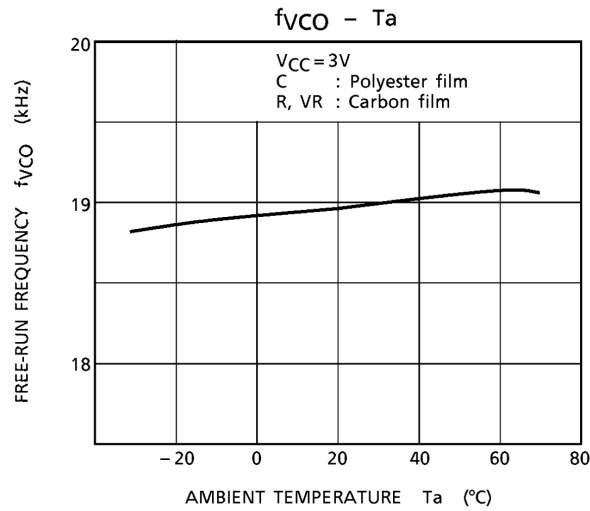

(2) Value of the external parts

We recommend to set up these value as below.

C = 1000pF

R = 12kΩ

VR = 10kΩ

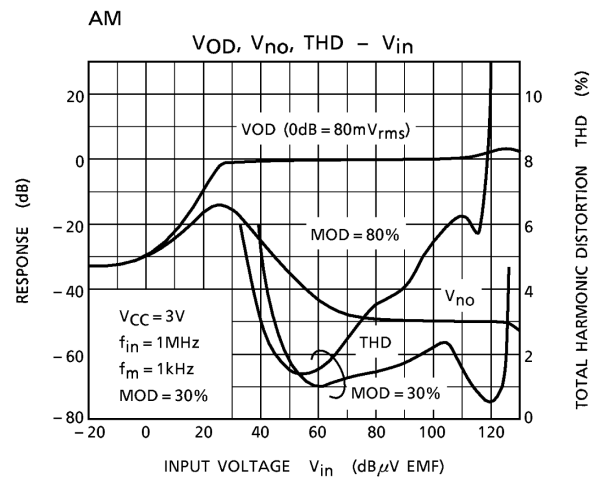
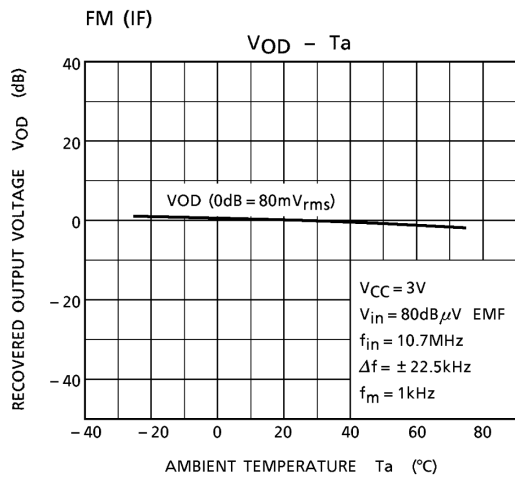
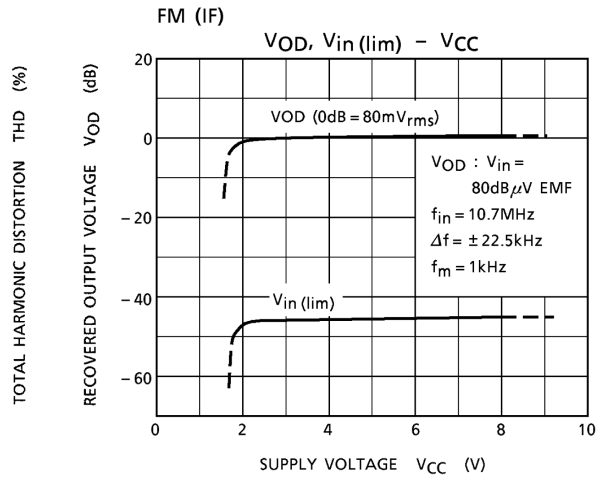
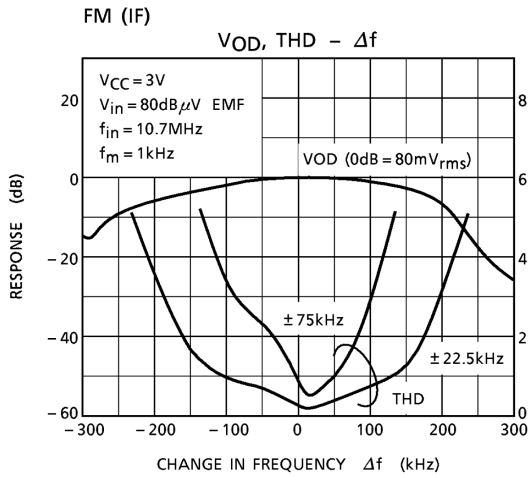
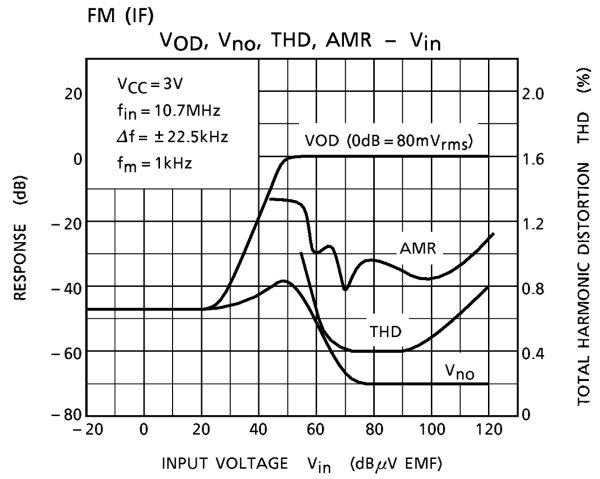
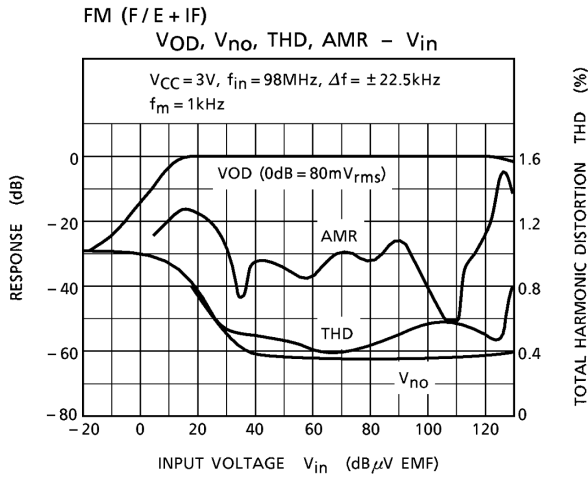

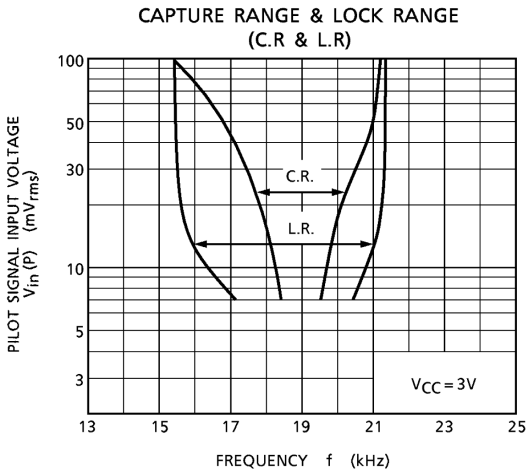
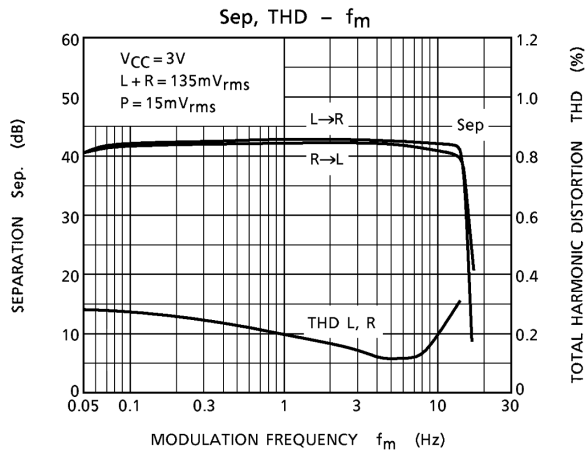
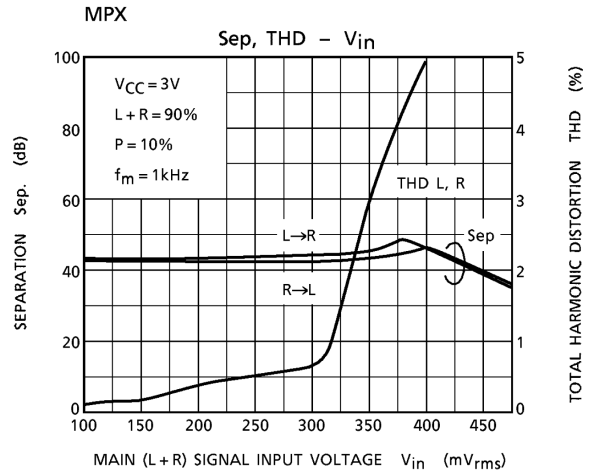
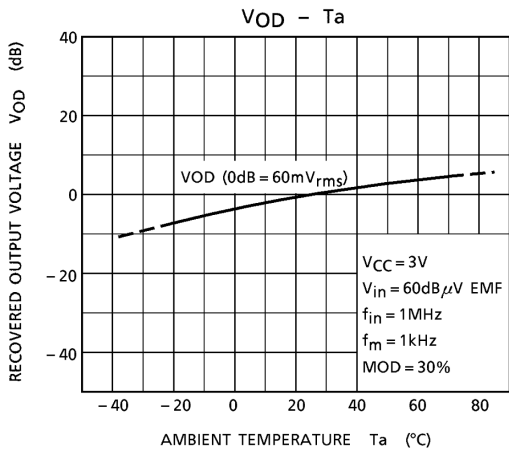
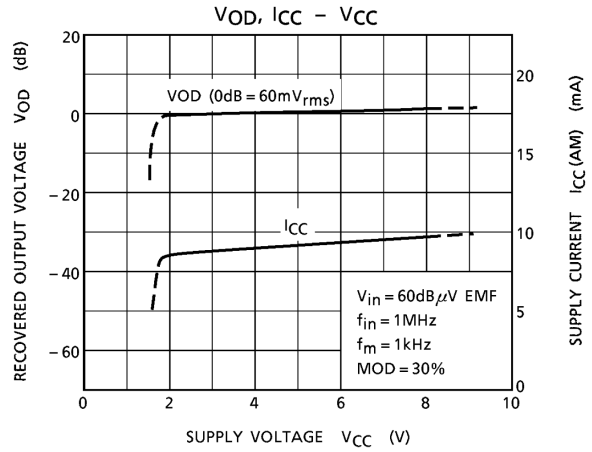
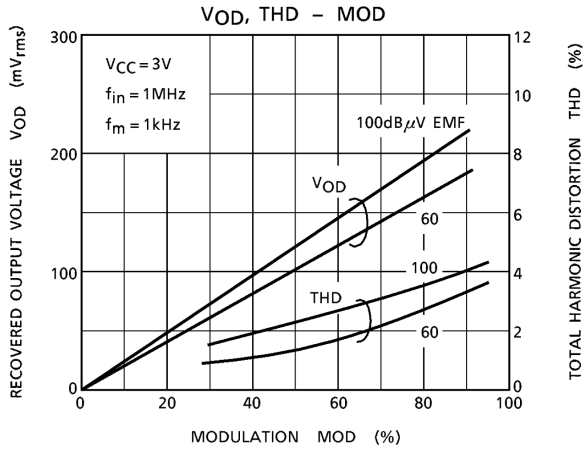

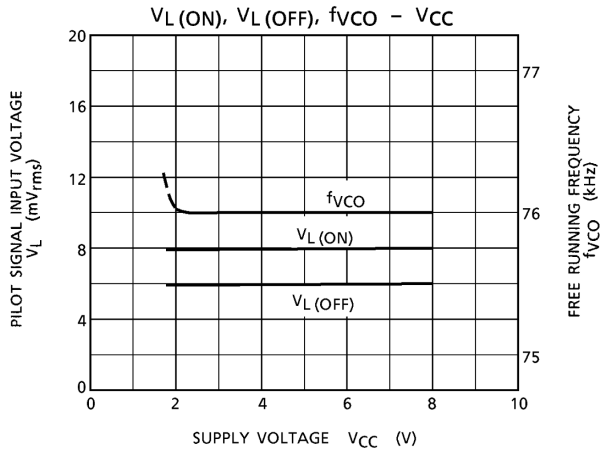
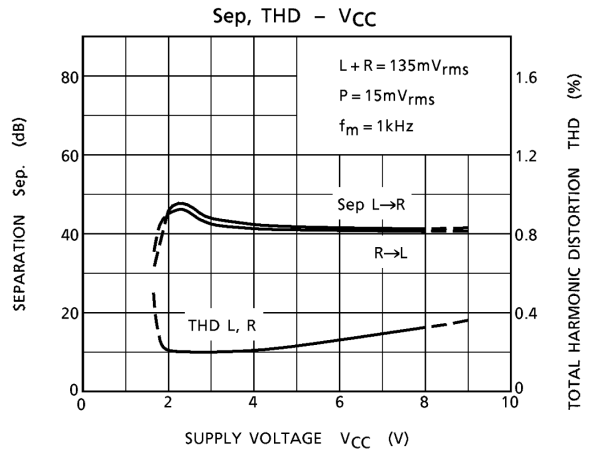
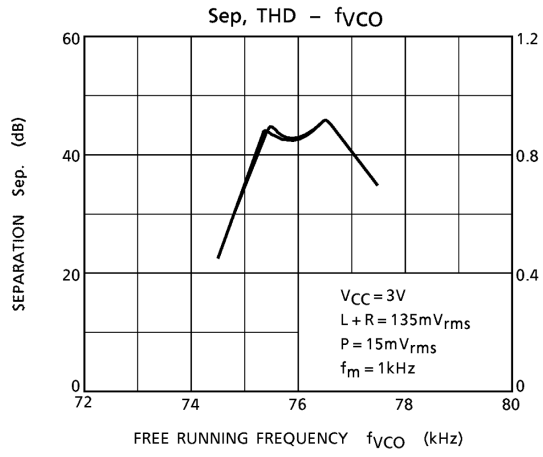

Package Dimensions

SDIP24-P-300-1.78

Unit : mm

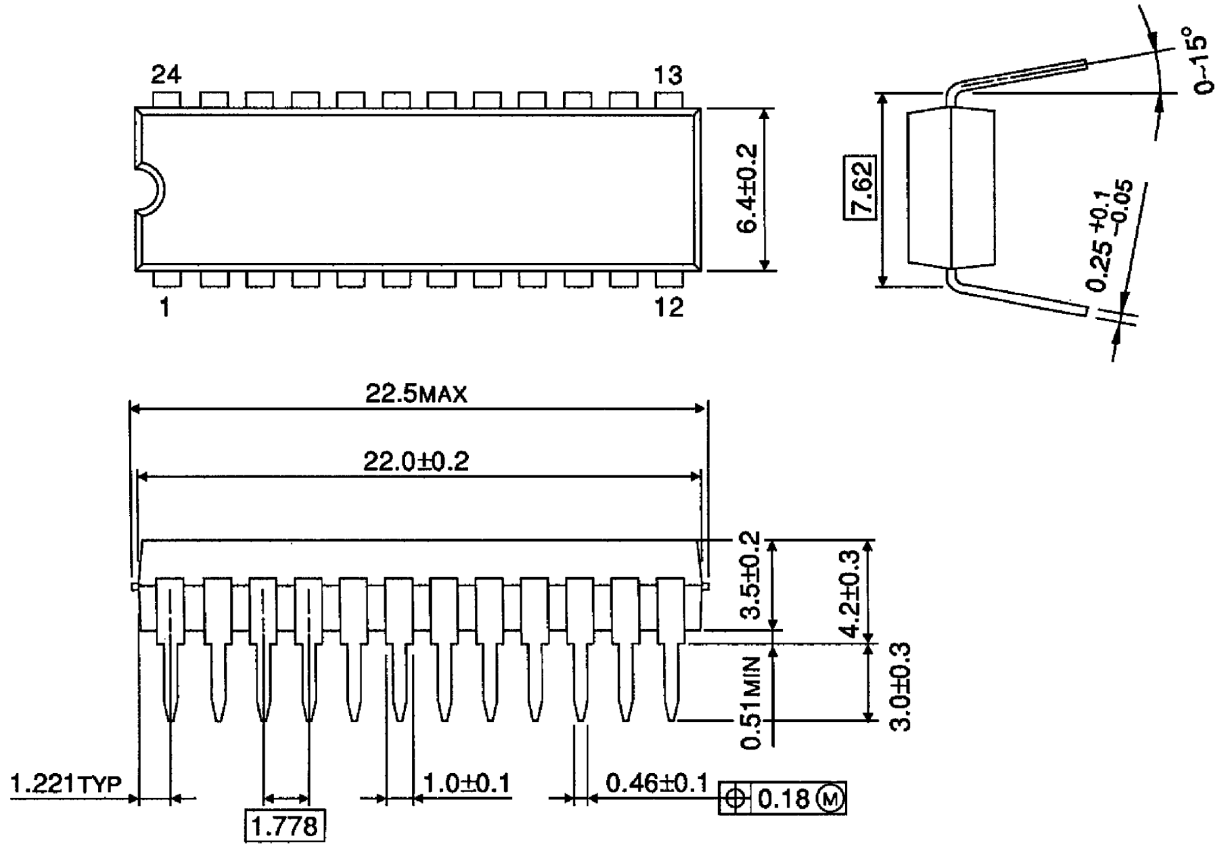

Weight: 1.2g (typ.)

RESTRICTIONS ON PRODUCT USE

000707EBA

- TOSHIBA is continually working to improve the quality and reliability of its products. Nevertheless, semiconductor devices in general can malfunction or fail due to their inherent electrical sensitivity and vulnerability to physical stress. It is the responsibility of the buyer, when utilizing TOSHIBA products, to comply with the standards of safety in making a safe design for the entire system, and to avoid situations in which a malfunction or failure of such TOSHIBA products could cause loss of human life, bodily injury or damage to property.
In developing your designs, please ensure that TOSHIBA products are used within specified operating ranges as set forth in the most recent TOSHIBA products specifications. Also, please keep in mind the precautions and conditions set forth in the "Handling Guide for Semiconductor Devices," or "TOSHIBA Semiconductor Reliability Handbook" etc..
- The TOSHIBA products listed in this document are intended for usage in general electronics applications (computer, personal equipment, office equipment, measuring equipment, industrial robotics, domestic appliances, etc.). These TOSHIBA products are neither intended nor warranted for usage in equipment that requires extraordinarily high quality and/or reliability or a malfunction or failure of which may cause loss of human life or bodily injury ("Unintended Usage"). Unintended Usage include atomic energy control instruments, airplane or spaceship instruments, transportation instruments, traffic signal instruments, combustion control instruments, medical instruments, all types of safety devices, etc.. Unintended Usage of TOSHIBA products listed in this document shall be made at the customer's own risk.
- The products described in this document are subject to the foreign exchange and foreign trade laws.
- The information contained herein is presented only as a guide for the applications of our products. No responsibility is assumed by TOSHIBA CORPORATION for any infringements of intellectual property or other rights of the third parties which may result from its use. No license is granted by implication or otherwise under any intellectual property or other rights of TOSHIBA CORPORATION or others.
- The information contained herein is subject to change without notice.