

VIF/SIF SYSTEM FOR COLOR TV

The KA2919 is a silicon monolithic integrated circuit containing the VIF section and SIF section on a single chip in the shrink-type 30SDIP package. Since the KA2919 is capable of performing video detection and sound detection independently or simultaneously, it can be applied to various sets from popular types to high-grade types, according to the designer's policy.

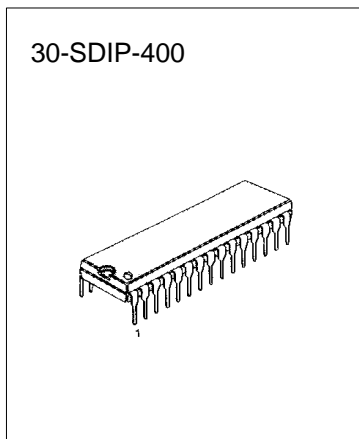

FUNCTIONS

VIF

- VIF Amp
- Video Det
- Peak IFAGC
- B/W Noise Canceller,
- RF AGC
- AFT
- SIF Det

SIF

- SIF Limiter Amp
- FM Det
- DC ATT
- AF Driver

ORDERING INFORMATION

Device	Package	Operating Temperature
KA2919	30-SDIP-400	-20°C ~+70°C

FEATURES

- High-Gain VIF amp requiring no preamp
- High AGC speed
- Provides wide-band detection characteristic and meets sound MPX demodulation requirements because of FM detection is quadrature detection
- Possible to use sound REC pin (Pin 2), AUX pin (Pin 3)
- Possible to mute video, sound for VTR Pin 7 GND: Muting of both video and sound
Pin 29 GND: Muting of sound only

BLOCK DIAGRAM

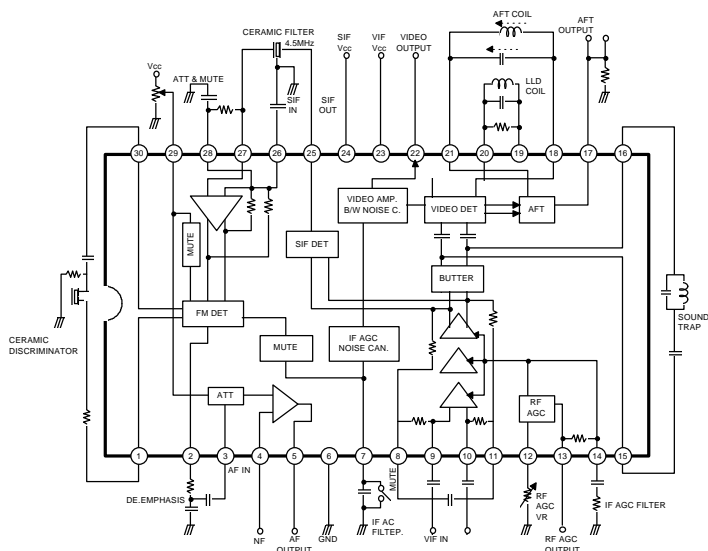

ELECTRICAL CHARACTERISTICS

VIF SECTION ($T_A = 25^\circ\text{C}$, $V_{CC} = 12\text{V}$, $f_P = 45.75\text{MHz}$, $f_S = 41.25\text{MHz}$ (VIF), $f_O = 4.5\text{MHz}$ (SIF))

Characteristics	Symbol	Test Condition	Min	Typ	Max	Unit	Test FIG.
Total Circuit Current	$I_{23}+I_{24}$	DC	59	74	98	mA	1
Maximum RF AGC Voltage	V_{13H}	DC	8.5	8.9	9.2	V	1
Minimum RF AGC Voltage	V_{13L}	DC		0	0.5	V	1
Quiescent Video Output Voltage	V_{22}	DC	5.6	6.1	6.6	V	1
Quiescent AFT Output Voltage	V_{17}	DC	4.5	6.5	7.5	V	1
Input Sensitivity	S_{VI}	$f_m = 400\text{Hz}$ 40% AM, $V_O = 0.8V_{PP}$	30	36	42	dB μ	2
AGC Range	V_{AGC}	$f_m = 15\text{KHz}$ 78% AM, $V_O = \pm 1\text{dB}$	60	74		dB	2
Maximum Allowable Input	V_{MAX}	$f_m = 15\text{KHz}$ 78% AM, $V_O = \pm 1\text{dB}$	100	500		mV $_{rms}$	2
Video Output Amplitude	$V_{O(22)}$	$V_I = 10\text{mV}_{rms}$, $f_M = 15\text{KHz}$ 78% AM	1.9	2.2	2.5	V $_{P-P}$	2
Output S/N	S/N	$V_I = 10\text{mV}_{rms}$ CW	48	54		dB	2
Carrier Leakage	CL	$V_I = 100\text{mV}_{rms}$, $f_M = 15\text{KHz}$ 78% AM	50	57		dB	2
Maximum AFT Voltage	V_{17H}	$V_I = 10\text{mV}_{rms}$ SWEEP	11	11.5	12.0	V	2
Maximum AFT Voltage	V_{17L}	$V_I = 10\text{mV}_{rms}$ SWEEP	0	0.4	1.0	V	2
AFT Detection Sensitivity	S_f	$V_I = 10\text{mV}_{rms}$ SWEEP	70	100	140	mV/KHz	2
White Noise Threshold Level	V_{WTH}	$V_I = 10\text{mV}_{rms}$ SWEEP	6.4	6.8	7.2	V	2
White Noise Clamp Level	V_{WCL}	$V_I = 10\text{mV}_{rms}$ SWEEP	4.2	4.6	5.0	V	2
Black Noise Threshold Level	V_{BTH}	$V_I = 10\text{mV}_{rms}$ SWEEP	1.9	2.2	2.5	V	2
Black Noise Clamp Level	V_{BCL}	$V_I = 10\text{mV}_{rms}$ SWEEP	3.8	4.2	4.6	V	2
SIF Output Signal Voltage	$V_{O(25)}$	P/S = 20dB	40	60	100	mV $_{rms}$	2
Frequency Characteristic	f_c	-3dB	6	8		MHz	2
Differential Gain	DG	$V_I = 10\text{mV}_{rms}$ 87.5% VIDEOMOD		4	10	%	2
Differential Phase	DP	$V_I = 10\text{mV}_{rms}$ 87.5% VIDEOMOD		3	6	deg	2
Input Resistance	R_I		1.0	1.5	2.0	Kohm	2
Input Capacitance	C_I			3.5	7.0	pF	2

*Electronic Volume Control Characteristic

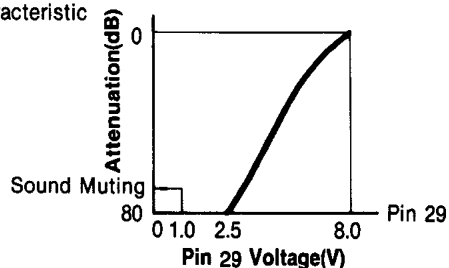

SIF SECTION ($T_A = 25^\circ\text{C}$, $V_{CC} = 12\text{V}$, $f_P = 45.75\text{MHz}$, $f_S = 41.25\text{MHz}$ (VIF), $f_O = 4.5\text{MHz}$ (SIF))

Characteristics	Symbol	Test Condition	Min	Typ	Max	Unit	Test FIG.
SIF Limiting Voltage	VI (LIM)	-3dB		200	400	μV_{rms}	2
Detection Output Voltage	V_O (2)	$V_I = 100\text{mV}_{\text{rms}}$, $f_m = 400\text{Hz}$, $f = \pm 25\text{KHz}$	450	680	850	mV_{rms}	2
Distortion	THD (2)	$V_I = 100\text{mV}_{\text{rms}}$, $f_m = 400\text{Hz}$, $f = \pm 25\text{KHz}$		0.5	1.0	%	2
AM Rejection	AMR	$V_I = 100\text{mV}_{\text{rms}}$, $f_m = 400\text{Hz}$, $f = \pm 25\text{KHz}$ 30% AM	50	60		dB	2
DCVR Maximum Attenuation	ATT	$V_I = 200\text{mV}_{\text{rms}}$, $f = 400\text{Hz}$	70	80		dB	2
AF Amp Gain	G_{AF}	$V_I = 100\text{mV}_{\text{rms}}$, $f = 400\text{Hz}$	18	20	22	dB	2
AF Amp Outpt Voltage	V_O (5)	V_O (5) THD = 10%, $f = 400\text{Hz}$	3	4		V_{rms}	2

TEST CIRCUIT

1. DC TEST

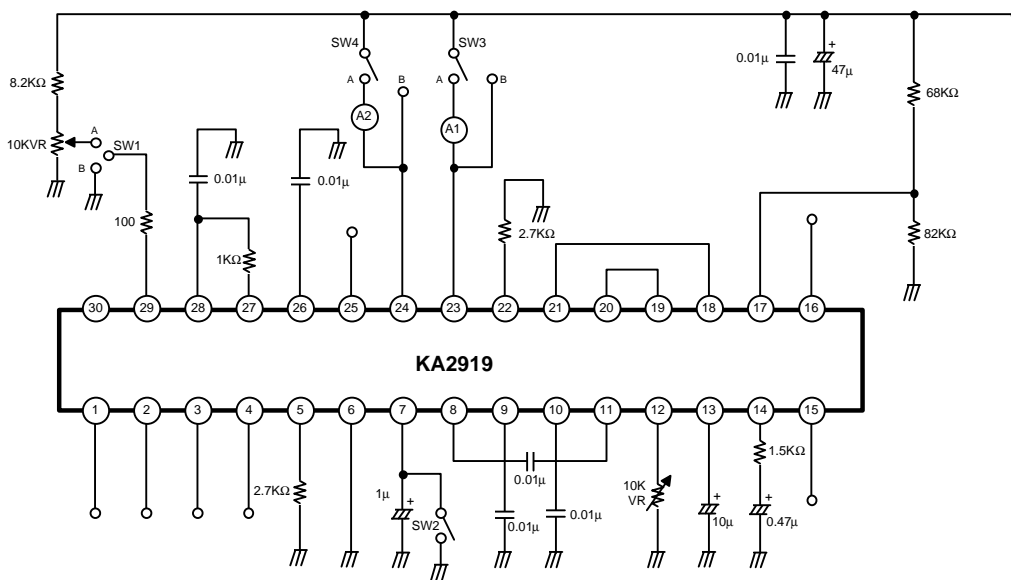

2. AC TEST

