

SANYO

No. 5467

LC78622E**Compact Disc Player DSP****Overview**

The LC78622E is a CMOS LSI that implements the signal processing and servo control required by compact disc players. At the same time as providing an EFM PLL circuit, a 1-bit D/A converter, and an analog low-pass filter the LC78622E realizes an optimal cost-performance tradeoff for low-end players by strictly limiting functionality to basic signal-processing and servo system functionality. The LC78622E signal-processing system provides demodulation of the EFM signal from the pickup, de-interleaving, error detection and correction, and digital filters that can prove useful in reducing the cost of end products. The LC78622E servo control system processes servo commands sent from the control microprocessor.

Functions

- Input signal processing: The LC78622E takes an HF signal as input, digitizes (slices) that signal at a precise level, converts that signal to an EFM signal, and generates a PLL clock with an average frequency of 4.3218 MHz by comparing the phases of that signal and an internal VCO.
- Precise reference clock and necessary internal timing generation using an external 16.9344 MHz crystal oscillator
- Disk motor speed control using a frame phase difference signal generated from the playback clock and the reference clock
- Frame synchronization signal detection, protection and interpolation to assure stable data readout
- EFM signal demodulation and conversion to 8-bit symbol data
- Subcode data separation from the EFM demodulated signal and output of that data to an external microprocessor
- Subcode Q signal output to a microprocessor over the serial I/O interface after performing a CRC error check (LSB first)
- Demodulated EFM signal buffering in internal RAM to handle up to ± 4 frames of disk rotational jitter
- Demodulated EFM signal reordering in the prescribed order for data unscrambling and de-interleaving
- Error detection, correction, and flag processing (error correction scheme: dual C1 plus dual C2 correction)

- The LC78622E sets the C2 flags based on the C1 flags and a C2 check, and then performs signal interpolation or muting depending on the C2 flags. The interpolation circuit uses a dual-interpolation scheme. The previous value is held if the C2 flags indicate errors two or more times consecutively.
- Support for command input from a control microprocessor: commands include track jump, focus start, disk motor start/stop, muting on/off and track count (8 bit serial input)
- Built-in digital output circuits.
- Arbitrary track counting to support high-speed data access
- D/A converter outputs with data continuity improved by 4x oversampling digital filters.
- Built-in third-order $\Sigma\Delta$ D/A converters (An analog low-pass filter is built in.)
- Built-in digital attenuator (8 bits – alpha, 239 steps)
- Built-in digital de-emphasis
- Zero cross muting
- Supports the implementation of a double-speed dubbing function.
- Support for bilingual applications.
- General-purpose I/O ports: 5 pins

Features

- 5 V single-voltage power supply
- Supports low-voltage operation (3.0 V, minimum)

Package Dimensions

unit: mm

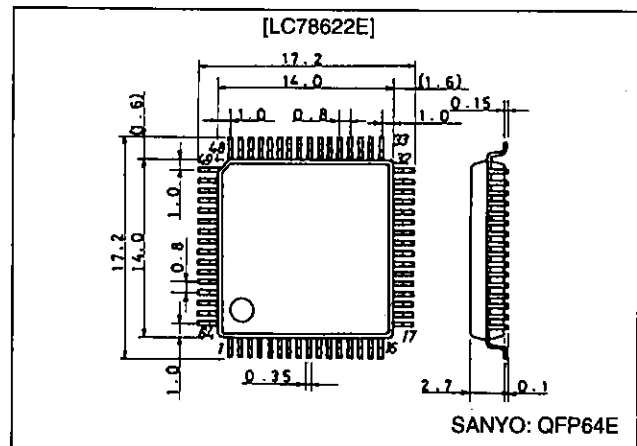
3159-QFP64E**SANYO Electric Co., Ltd. Semiconductor Business Headquarters**

TOKYO OFFICE Tokyo Bldg., 1-10, 1 Chome, Ueno, Taito-ku, TOKYO, 110 JAPAN

LC78622E

Equivalent Circuit Block Diagram

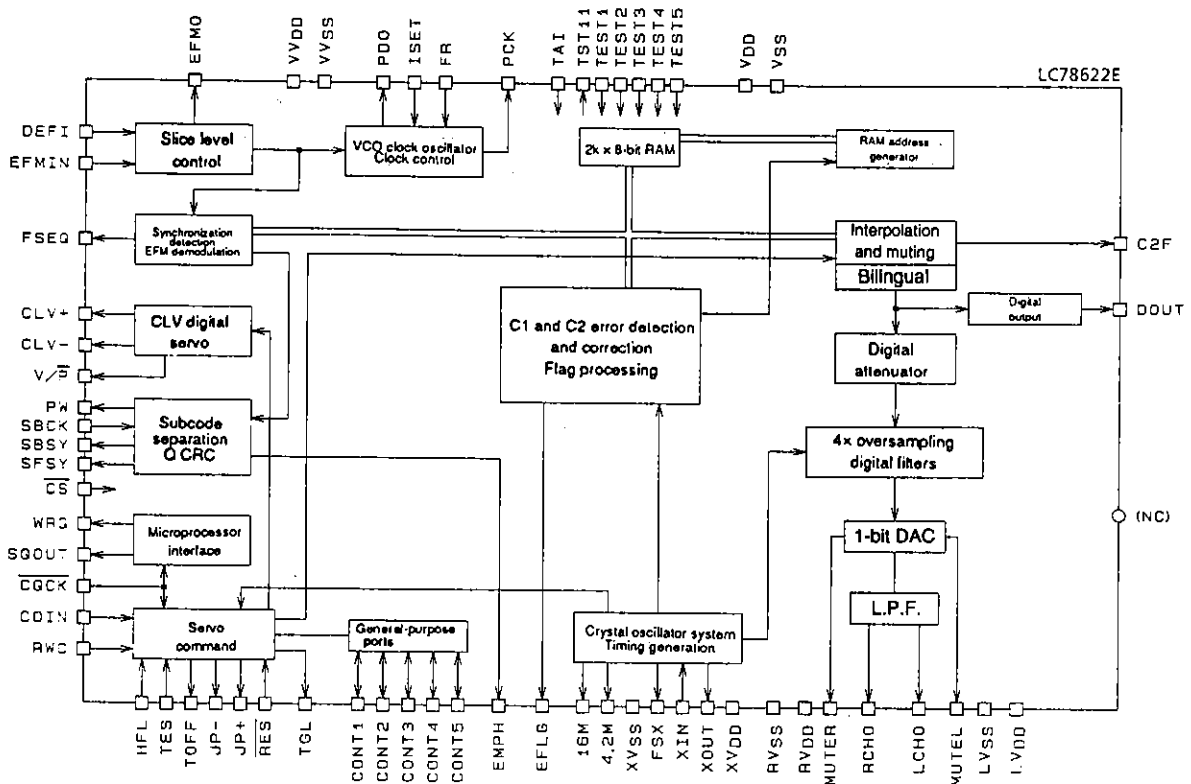

A05672

Pin Assignment

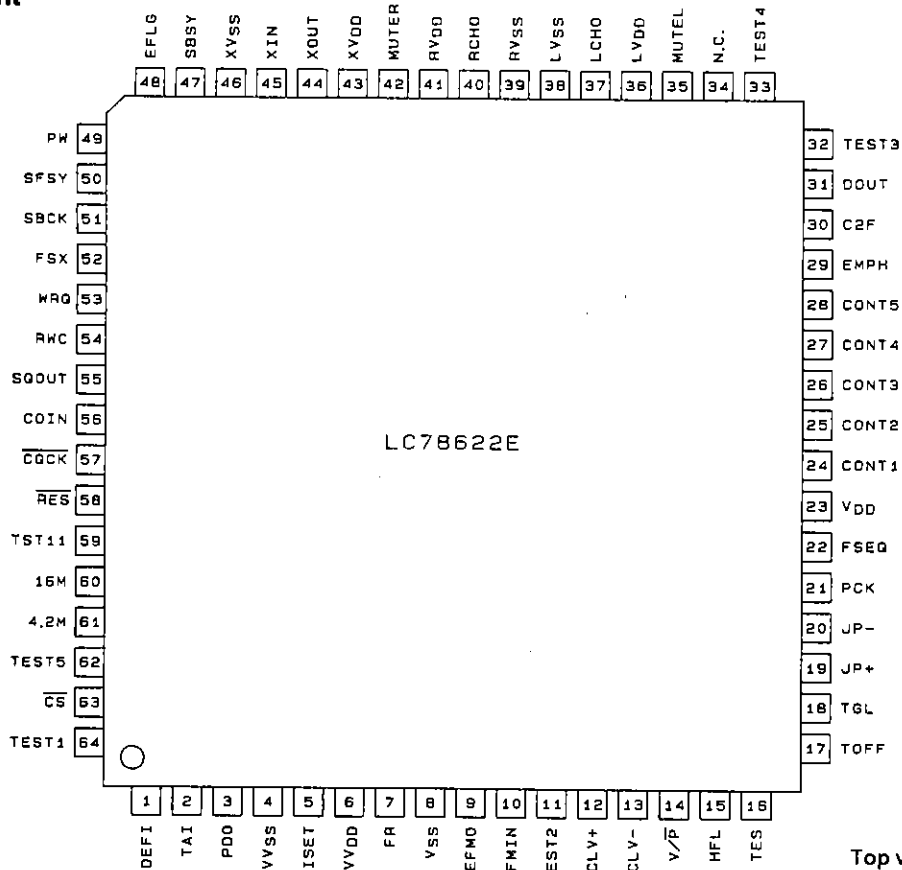

Top view

A05673

Specifications

Absolute Maximum Ratings at $T_a = 25^\circ\text{C}$, $V_{SS} = 0\text{ V}$

Parameter	Symbol	Conditions	Ratings	Unit
Maximum supply voltage	$V_{DD\text{ max}}$		$V_{SS} - 0.3$ to $V_{SS} + 7.0$	V
Input voltage	V_{IN}		$V_{SS} - 0.3$ to $V_{DD} + 0.3$	V
Output voltage	V_{OUT}		$V_{SS} - 0.3$ to $V_{DD} + 0.3$	V
Allowable power dissipation	$P_d\text{ max}$		300	mW
Operating temperature	T_{opr}		-20 to +75	$^\circ\text{C}$
Storage temperature	T_{stg}		-40 to +125	$^\circ\text{C}$

Allowable Operating Ranges at $T_a = 25^\circ\text{C}$, $V_{SS} = 0\text{ V}$

Parameter	Symbol	Conditions	min	typ	max	Unit
Supply voltage	$V_{DD}\text{ (1)}$	V_{DD} , XV_{DD} , LV_{DD} , RV_{DD} , VV_{DD} : During normal-speed playback	3.0		5.5	V
	$V_{DD}\text{ (2)}$	V_{DD} , XV_{DD} , LV_{DD} , RV_{DD} , VV_{DD} : During double-speed playback	3.6		5.5	V
Input high level voltage	$V_{IH}\text{ (1)}$	DEFI, COIN, \overline{RES} , HFL, TES, SBCK, RWC, \overline{CQCK} , TAI, TEST1 to TEST5, \overline{CS} , CONT1 to CONT5	$0.7 V_{DD}$		V_{DD}	V
	$V_{IH}\text{ (2)}$	EFMIN	$0.6 V_{DD}$		V_{DD}	V
Input low level voltage	$V_{IL}\text{ (1)}$	DEFI, COIN, \overline{RES} , HFL, TES, SBCK, RWC, \overline{CQCK} , TAI, TEST1 to TEST5, \overline{CS} , CONT1 to CONT5	0		$0.3 V_{DD}$	V
	$V_{IL}\text{ (2)}$	EFMIN	0		$0.4 V_{DD}$	V
Data setup time	t_{SU}	COIN, RWC: Figure 1	400			ns
Data hold time	t_{HD}	COIN, RWC: Figure 1	400			ns
High level clock pulse width	t_{WH}	SBCK, \overline{CQCK} : Figures 1, 2 and 3	400			ns
Low level clock pulse width	t_{WL}	SBCK, \overline{CQCK} : Figures 1, 2 and 3	400			ns
Data read access time	t_{RAC}	SQOUT, PW: Figures 2 and 3	0		400	ns
Command transfer time	t_{RWC}	RWC: Figure 1	1000			ns
Subcode Q read enable time	t_{SQE}	WRQ: Figure 2, with no RWC signal		11.2		ms
Subcode read cycle time	t_{SC}	SFSY: Figure 3		136		μs
Subcode read enable time	t_{SE}	SFSY: Figure 3	400			ns
Port input data setup time	t_{CSU}	CONT1 to CONT5, RWC: Figure 4	400			ns
Port input data hold time	t_{CHD}	CONT1 to CONT5, RWC: Figure 4	400			ns
Port input clock setup time	t_{RCQ}	RWC, \overline{CQCK} : Figure 4	100			ns
Port output data delay time	t_{CDD}	CONT1 to CONT5, RWC: Figure 5			1200	ns
Input level	$V_{IN}\text{ (1)}$	EFMIN: Slice level control	1.0			Vp-p
	$V_{IN}\text{ (2)}$	X_{IN} : Capacitor-coupled input	1.0			Vp-p
Operating frequency range	f_{op}	EFMIN			10	MHz
Crystal oscillator frequency	f_X	X_{IN} , X_{OUT}		16.9344		MHz

LC78622E

Electrical Characteristics at $T_a = 25^\circ\text{C}$, $V_{DD} = 5\text{ V}$, $V_{SS} = 0\text{ V}$

Parameter	Symbol	Conditions	min	typ	max	Unit
Current drain	I_{DD}	V_{DD} , XV_{DD} , LV_{DD} , RV_{DD} , VV_{DD}		25	35	mA
Input high level current	I_{IH} (1)	DEFI, EFMIN, COIN, RES, HFL, TES, SBCK, RWC, CQCK: TEST1: $V_{IN} = V_{DD}$			5	μA
	I_{IH} (2)	TAI, TEST2 to TEST5, CS: $V_{IN} = V_{DD} = 5.5\text{ V}$	25		75	μA
Input low level current	I_{IL}	DEFI, EFMIN, COIN, RES, HFL, TES, SBCK, RWC, CQCK, TAI, TEST1 to TEST5, CS: $V_{IN} = 0\text{ V}$	-5			μA
Output high level voltage	V_{OH} (1)	EFMO, CLV-, CLV-, V/\bar{P} , PCK, FSEQ, TOFF, TGL, JP-, JP-, EMPH, EFLG, FSX: $I_{OH} = -1\text{ mA}$	4			V
	V_{OH} (2)	MUTEL, MUTER, C2F, SBSY, PW, SFSY, WRQ, SQOUT, TST11, 16M, 4.2M, CONT1 to CONT5: $I_{OH} = -0.5\text{ mA}$	4			V
	V_{OH} (3)	DOUT: $I_{OH} = -12\text{ mA}$	4.5			V
Output low level voltage	V_{OL} (1)	EFMO, CLV-, CLV-, V/\bar{P} , PCK, FSEQ, TOFF, TGL, JP-, JP-, EMPH, EFLG, FSX: $I_{OH} = 1\text{ mA}$			1	V
	V_{OL} (2)	MUTEL, MUTER, C2F, SBSY, PW, SFSY, WRQ, SQOUT, TST11, 16M, 4.2M, CONT1 to CONT5: $I_{OH} = 2\text{ mA}$			0.4	V
	V_{OL} (3)	DOUT: $I_{OH} = 12\text{ mA}$			0.5	V
Output off leakage current	I_{OFF} (1)	PDO, CLV-, CLV-, JP-, JP-, CONT1 to CONT5: $V_{OUT} = V_{DD}$			5	μA
	I_{OFF} (2)	PDO, CLV-, CLV-, JP-, JP-, CONT1 to CONT5: $V_{OUT} = 0\text{ V}$	-5			μA
Charge pump output current	I_{PDDH}	PDO: $R_{ISET} = 68\text{ k}\Omega$	64	80	96	μA
	I_{PDOL}	PDO: $R_{ISET} = 68\text{ k}\Omega$	-96	-80	-64	μA

One-Bit D/A Converter Analog Characteristics

at $T_a = 25^\circ\text{C}$, $V_{DD} = LV_{DD} = RV_{DD} = 5\text{ V}$, $V_{SS} = LV_{SS} = RV_{SS} = 0\text{ V}$

Parameter	Symbol	Conditions	min	typ	max	Unit
Total harmonic distortion	THD + N	LCHO, RCHO; 1 kHz: 0 dB data input, using the 20 kHz low-pass filter (AD725D built in)		0.011	0.013	%
Dynamic range	DR	LCHO, RCHO; 1 kHz: -60 dB data input, using the 20 kHz low-pass filter and the A filter (AD725D built in)	91	92		dB
Signal-to-noise ratio	S/N	LCHO, RCHO; 1 kHz: 0 dB data input, using the 20 kHz low-pass filter and the A filter (AD725D built in)	93	95		dB
Crosstalk	CT	LCHO, RCHO; 1 kHz: 0 dB data input, using the 20 kHz low-pass filter (AD725D built in)	82	84		dB

Note: Measured with the normal-speed playback mode in the Sanyo one-bit D/A converter block reference digital attenuator circuit set to EE (hexadecimal).

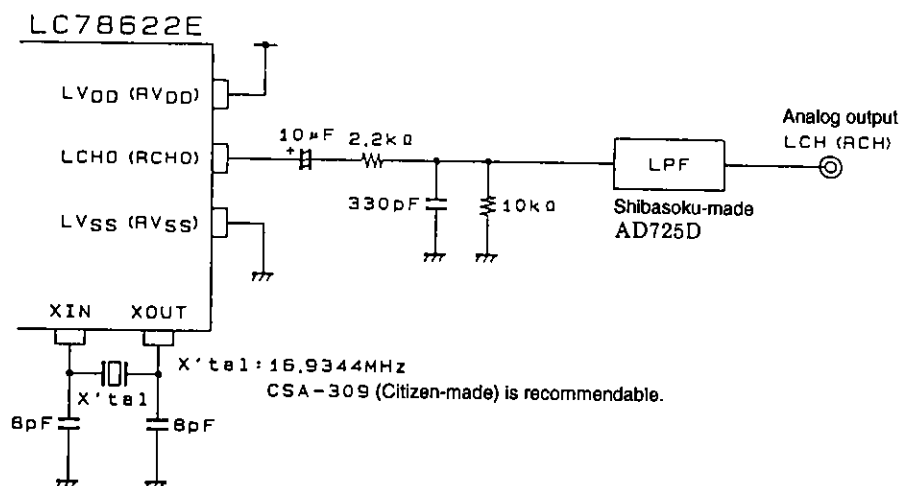

A05874

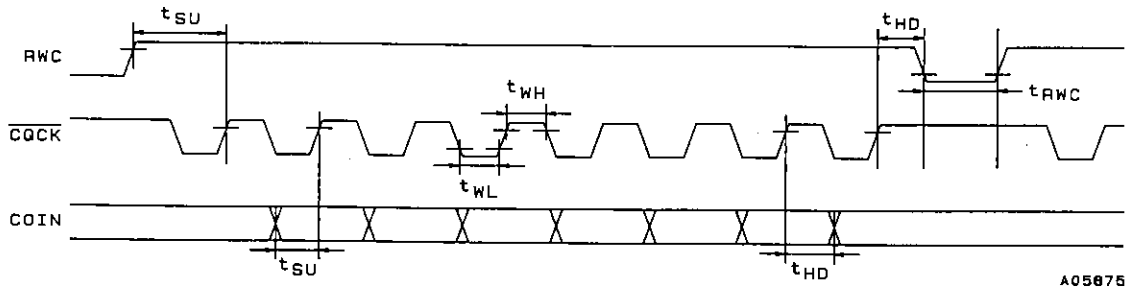

Figure 1 Command Input

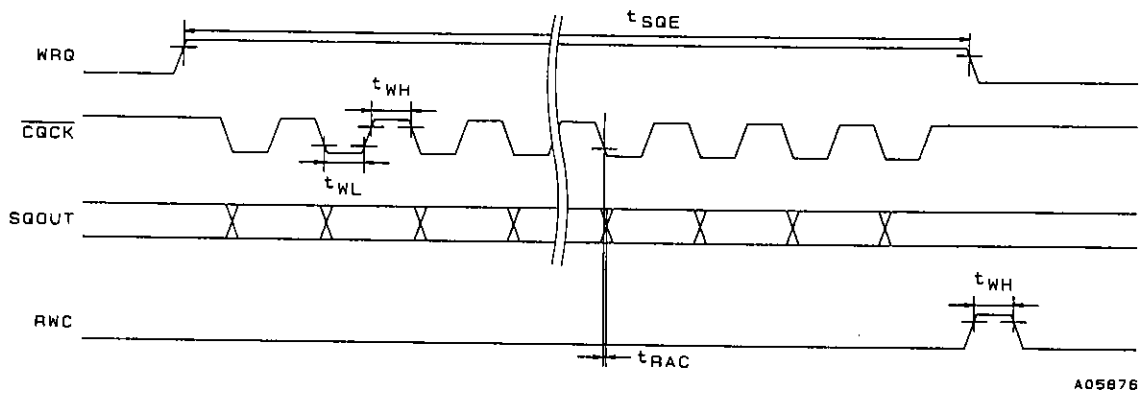

Figure 2 Subcode Q Output

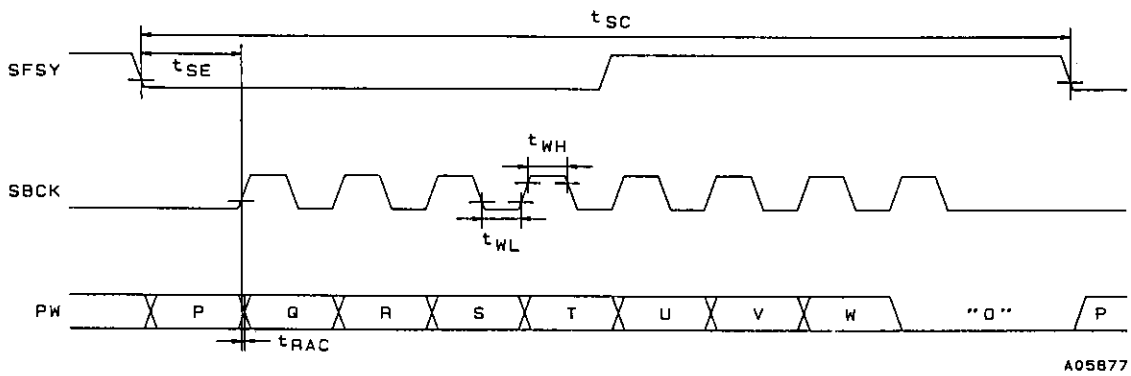
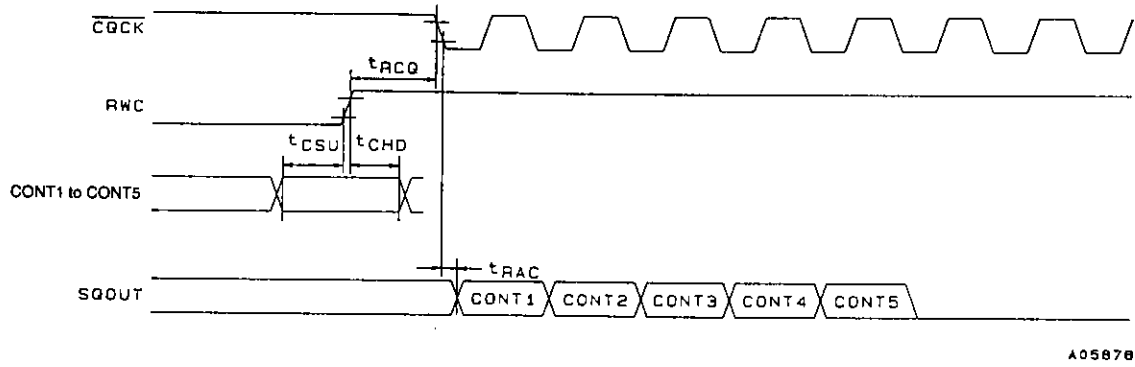
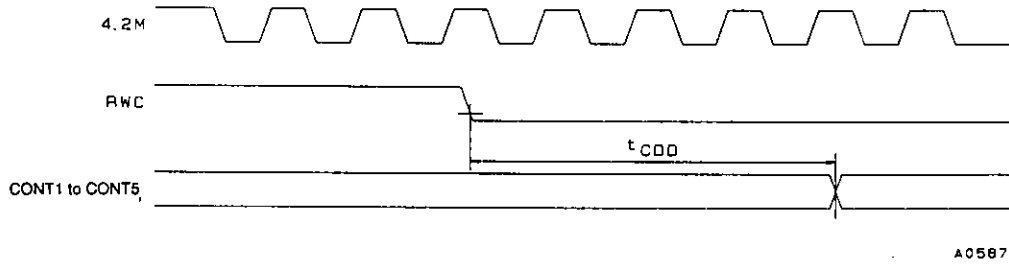

Figure 3 Subcode Output



A05878

Figure 4 General-Purpose Port Input Timing



A05879

Figure 5 General-Purpose Port Output Timing

LC78622E

Pin Functions

Pin No.	Symbol	I/O	Function		
1	DEFI	I	Defect detection signal (DEF) input. (Must be connected to 0 V when unused.)		
2	TAI	I	PLL pins	Test input. A pull-down resistor is built in. Must be connected to 0 V.	
3	PDO	O		External VCO control phase comparator output	
4	V _{SS}	-		Internal VCO ground. Must be connected to 0 V.	
5	ISET	AI		PDO output current adjustment resistor connection	
6	V _{DD}	-		Internal VCO power supply	
7	FR	AI		VCO frequency range adjustment	
8	V _{SS}	-		Digital system ground. Must be connected to 0 V.	
9	EFMO	O	Slice level control	EFM signal output	
10	EFMIN	I		EFM signal input	
11	TEST2	I	Test input. A pull-down resistor is built in. Must be connected to 0 V.		
12	CLV+	O	Disc motor control output.		
13	CLV-	O	Three-value output is also possible when specified by microprocessor command.		
14	V/P	O	Rough servo/phase control automatic switching monitor output. Outputs a high level during rough servo and a low level during phase control.		
15	HFL	I	Track detection signal input. This is a Schmitt input.		
16	TES	I	Tracking error signal input. This is a Schmitt input.		
17	TOFF	O	Tracking off output		
18	TGL	O	Tracking gain switching output. Increase the gain when low.		
19	JP+	O	Track jump output.		
20	JP-	O	Three-value output is also possible when specified by microprocessor command.		
21	PCK	O	EFM data playback clock monitor. Outputs 4.3218 MHz when the phase is locked.		
22	FSEQ	O	Synchronization signal detection output. Outputs a high level when the synchronization signal detected from the EFM signal and the internally generated synchronization signal agree.		
23	V _{DD}	-	Digital system power supply.		
24	CONT1	I/O	General-purpose I/O pin 1	Controlled by serial data commands from the microprocessor. Any of these that are unused must be either set up as input ports and connected to 0 V, or set up as output ports and left open.	
25	CONT2	I/O			General-purpose I/O pin 2
26	CONT3	I/O			General-purpose I/O pin 3
27	CONT4	I/O			General-purpose I/O pin 4
28	CONT5	I/O			General-purpose I/O pin 5
29	EMPH	O	De-emphasis monitor pin. A high level indicates playback of a de-emphasis disk.		
30	C2F	O	C2 flag output		
31	DOUT	O	Digital output. (EIAJ format)		
32	TEST3	I	Test input. A pull-down resistor is built in. Must be connected to 0 V.		
33	TEST4	I	Test input. A pull-down resistor is built in. Must be connected to 0 V.		
34	N.C.	-	Unused. Must be left open.		
35	MUTEL	O	Left channel one-bit D/A converter	Left channel mute output	
36	LV _{DD}	-		Left channel power supply	
37	LCHO	O		Left channel output	
38	LV _{SS}	-		Left channel ground. Must be connected to 0 V.	
39	RV _{SS}	-	Right channel one-bit D/A converter	Right channel ground. Must be connected to 0 V.	
40	RCHO	O		Right channel output	
41	RV _{DD}	-		Right channel power supply	
42	MUTER	O		Right channel mute output	
43	XV _{DD}	-	Crystal oscillator power supply.		
44	X _{OUT}	O	Connections for a 16.9344 crystal oscillator element		
45	X _{IN}	I			
46	XV _{SS}	-	Crystal oscillator ground. Must be connected to 0 V.		
47	SBSY	O	Subcode block synchronization signal output		
48	EFLG	O	C1, C2, single and double error correction monitor pin		
49	PW	O	Subcode P, Q, R, S, T, U, V and W output		
50	SFSY	O	Subcode frame synchronization signal output. This signal falls when the subcodes are in the standby state.		

Continued on next page.

Continued from preceding page.

Pin No.	Symbol	I/O	Function
51	SBCK	I	Subcode readout clock input. This is a Schmitt input. (Must be connected to 0 V when unused.)
52	FSX	O	Output for the 7.35 kHz synchronization signal divided from the crystal oscillator
53	WRQ	O	Subcode Q output standby output
54	RWC	I	Read/write control input. This is a Schmitt input.
55	SQOUT	O	Subcode Q output
56	COIN	I	Command input from the control microprocessor
57	COCK	I	Input for both the command input clock and the subcode readout clock. This is a Schmitt input.
58	RES	I	Chip reset Input. This pin must be set low briefly after power is first applied.
59	TST11	O	Test output. Leave open. (Normally outputs a low level.)
60	16M	O	16.9344 MHz output.
61	4.2M	O	4.2336 MHz output
62	TEST5	I	Test input. A pull-down resistor is built in. Must be connected to 0 V.
63	CS	I	Chip select Input. A pull-down resistor is built in. Must be connected to 0 V if not controlled.
64	TEST1	I	Test input. No pull-down resistor. Must be connected to 0 V.

Note: The same potential must be supplied to all power supply pins, i.e., V_{DD} , VV_{DD} , LV_{DD} , RV_{DD} , and XV_{DD} .

Pin Applications

1. HF Signal Input Circuit; Pin 10: EFMIN, pin 9: EFMO, pin 1: DEFI, pin 12: CLV*

An EFM signal (NRZ) sliced at an optimal level can be acquired by inputting the HF signal to EFMIN.

The LC78622E handles defects as follows. When a high level is input to the DEFI pin (pin 1), EFMO (pin 9) pins (the slice level control outputs) go to the high-impedance state, and the slice level is held. However, note that this function is only valid in CLV phase control mode, that is, when the V/P pin (pin 14) is low. This function can be used in combination with the LA9230M, LA9231M and LA9240M DEF pins.

Note: If the EFMIN and CLV* signal lines are too close to each other, unwanted radiation can result in error rate degradation. We recommend laying a ground or V_{DD} shield line between these two lines.

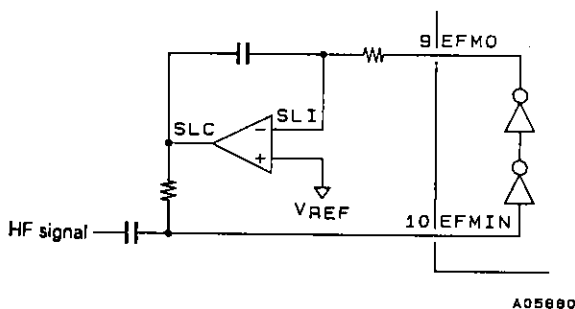

2. PLL Clock Generation Circuit; Pin 3: PDO, pin 5: ISET, pin 7: FR, pin 21: PCK

Since the LC78622E includes a VCO circuit, a PLL circuit can be formed by connecting an external RC circuit. ISET is the charge pump reference current, PDO is the VCO circuit loop filter, and FR is a resistor that determines the VCO frequency range.

(Reference values)
 $R1 = 68 \text{ k}\Omega$, $C1 = 0.1 \text{ }\mu\text{F}$
 $R2 = 680 \text{ }\Omega$, $C2 = 0.1 \text{ }\mu\text{F}$
 $R3 = 1.2 \text{ k}\Omega$

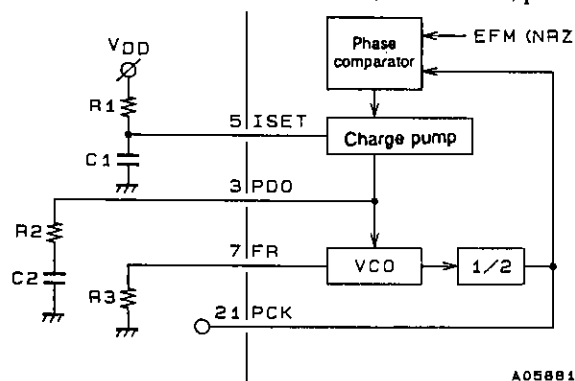

Code	COMMAND	$\overline{\text{RES}} = \text{[L]}$
\$AC	$V_{CO} \times 2$ SET	
\$AD	$V_{CO} \times 1$ SET	©

The $V_{CO} \times 2$ command is an auxiliary command for characteristics guarantee in low-voltage operations. This command supports the low-voltage operations at $V_{DD} = 3.0$ to 3.6 V .

3. VCO Monitor; Pin 21: PCK
PCK is a monitor pin that outputs an average frequency of 4.3218 MHz, which is divided from the VCO frequency.
4. Synchronization Detection Monitor; Pin 22: FSEQ
Pin 22 goes high when the frame synchronization (a positive polarity synchronization signal) from the EFM signal read in by PCK and the timing generated by the counter (the interpolation synchronization signal) agree. This pin is thus a synchronization detection monitor. (It is held high for a single frame.)
5. Servo Command Function; Pin 54: RWC, pin 56: COIN, pin 57: \overline{CQCK}
Commands can be executed by setting RWC high and inputting commands to the COIN pin in synchronization with the \overline{CQCK} clock. Note that commands are executed on the falling edge of RWC.

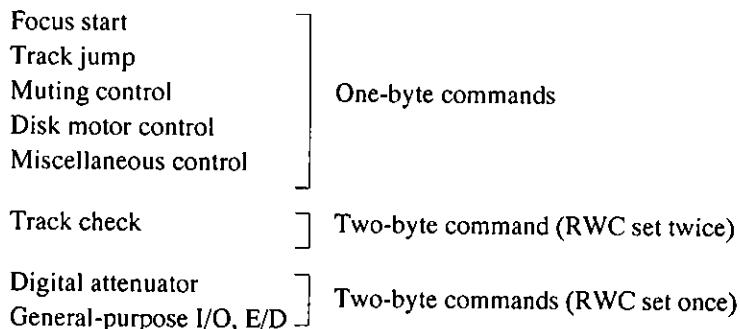

- One-byte commands

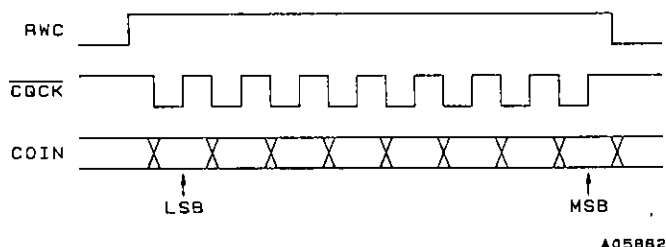

- Two-byte commands (RWC set twice: For track checking)

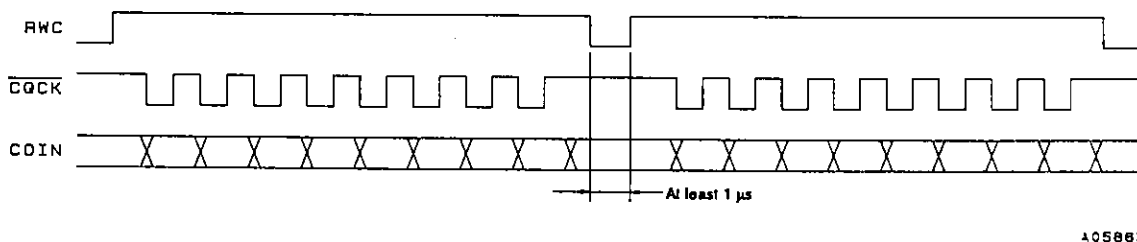

- Two-byte commands (RWC set once: Sets up the digital attenuation and the general-purpose I/O ports)

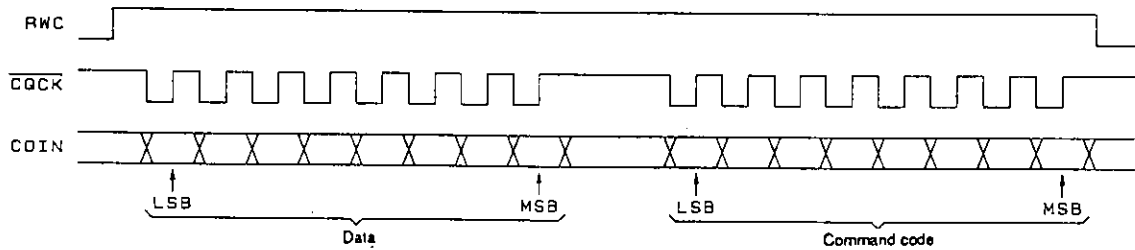

A05884

- Command noise rejection

MSB	LSB	Command	$\overline{RES} = \text{low}$
1	1	COMMAND INPUT NOISE REDUCTION MODE	
1	1	RESET NOISE EXCLUSION MODE	○

This command reduces the noise on the \overline{CQCK} clock signal. While this is effective for noise pulses shorter than 500 ns, the \overline{CQCK} timings t_{WL} , t_{WH} , and t_{SU} , must be set for at least 1 μs .

6. CLV Servo Circuit; Pin 12: CLV+, pin 13: CLV-, pin 14: V/\overline{P}

MSB	LSB	Command	$\overline{RES} = \text{low}$
0	0	DISC MOTOR START (accelerate)	
0	0	DISC MOTOR CLV (CLV)	
0	0	DISC MOTOR BRAKE (decelerate)	
0	0	DISC MOTOR STOP (stop)	○

The CLV+ pin provides the signal that accelerates the disk in the forward direction and the CLV- pin provides the signal that decelerates the disk. Commands from the control microprocessor select one of four modes; accelerate, decelerate, CLV and stop. The table below lists the CLV+ and CLV- outputs in each of these modes.

Mode	CLV+	CLV-
Accelerate	High	Low
Decelerate	Low	High
CLV	Pulse output	Pulse output
Stop	Low	Low

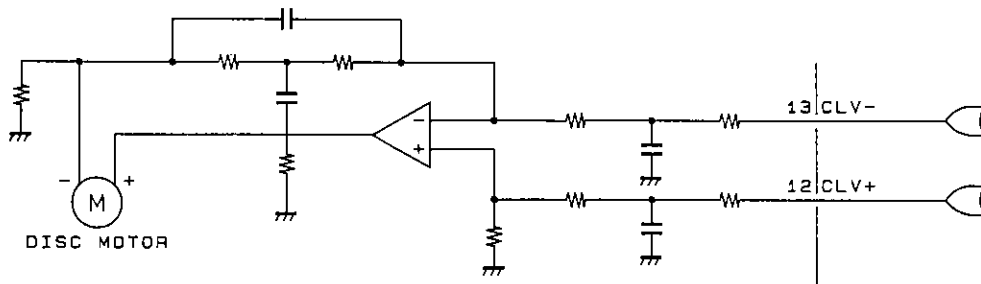

A05885

Note: CLV servo control commands can set the TOFF pin low only in CLV mode. That pin will be at the high level at all other times. Control of the TOFF pin by microprocessor command is only valid in CLV mode.

LC78622E

- CLV mode

In CLV mode the LC78622E detects the disk speed from the HF signal and provides proper linear speed using several different control schemes by switching the DSP internal modes. The PWM reference period corresponds to a frequency of 7.35 kHz. The V/P pin outputs a high level during rough servo and a low level during phase control.

Internal mode	CLV+	CLV-	V/P
Rough servo (velocity too low)	High	Low	High
Rough servo (velocity too high)	Low	High	High
Phase control (PCK locked)	PWM	PWM	Low

- Rough servo gain switching

MSB	LSB	Command	RES = low
1	0 1 0 1 0 0 0	DISC 8 SET	○
1	0 1 0 1 0 0 1	DISC 12 SET	

For 8 cm disks, the rough servo mode CLV control gain can be set about 8.5 dB lower than the gain used for 12 cm disks.

- Phase control gain switching

MSB	LSB	Command	RES = low
1	0 1 1 0 0 0 1	CLV PHASE COMPARATOR DIVISOR: 1/2	○
1	0 1 1 0 0 1 0	CLV PHASE COMPARATOR DIVISOR: 1/4	
1	0 1 1 0 0 1 1	CLV PHASE COMPARATOR DIVISOR: 1/8	
1	0 1 1 0 0 0 0	NO CLV PHASE COMPARATOR DIVISOR USED	

The phase control gain can be changed by changing the divisor used by the dividers in the stage immediately preceding the phase comparator.

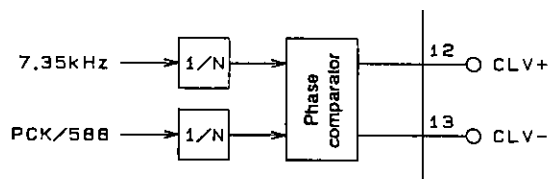

A05886

LC78622E

• CLV three-value output

MSB	LSB	Command	RES = low
1 0 1 1 0 1 0 0		CLV THREE VALUE OUTPUT	
1 0 1 1 0 1 0 1		CLV TWO VALUE OUTPUT (the scheme used by previous products)	○

The CLV three-value output command allows the CLV to be controlled by a single pin.

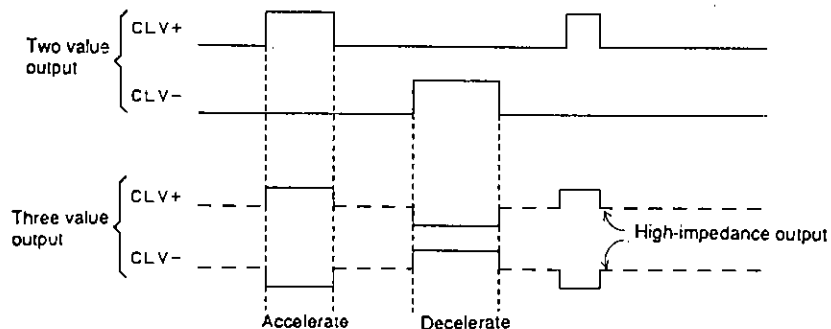

A05887

• Internal brake modes

MSB	LSB	Command	RES = low
1 1 0 0 0 1 0 1		INTERNAL BRAKE ON	
1 1 0 0 0 1 0 0		INTERNAL BRAKE OFF	○
1 0 1 0 0 0 1 1		INTERNAL BRAKE CONTROL	
1 1 0 0 1 0 1 1		INTERNAL BRAKE CONTINUOUS MODE	
1 1 0 0 1 0 1 0		RESET CONTINUOUS MODE	○
1 1 0 0 1 1 0 1		TON MODE DURING INTERNAL BRAKING	
1 1 0 0 1 1 0 0		RESET TON MODE	○

- Issuing the internal brake-on (C5H) command sets the LC78622E to internal brake mode. In this mode, the disk deceleration state can be monitored from the WRQ pin when a brake command (06H) is executed.
- In this mode the disk deceleration state is determined by counting the EFM signal density in a single frame, and when the EFM signal count falls under four, the CLV- pin is dropped to low. At the same time the WRQ signal, which functions as a brake completion monitor, goes high. When the microprocessor detects a high level on the WRQ signal, it should issue a STOP command to fully stop the disk. In internal brake continuous mode (CBH), the CLV- pin high-level output braking operation continues even after the WRQ brake completion monitor goes high.
 Note that if errors occur in deceleration state determination due to noise in the EFM signal, the problem may be rectified by changing the EFM signal count from four to eight with the internal brake control command (A3H).
- In TOFF output disabled mode (CDH), the TOFF pin is held low during internal brake operations. We recommend using this feature, since it is effective at preventing incorrect detection at the disk mirror surface.

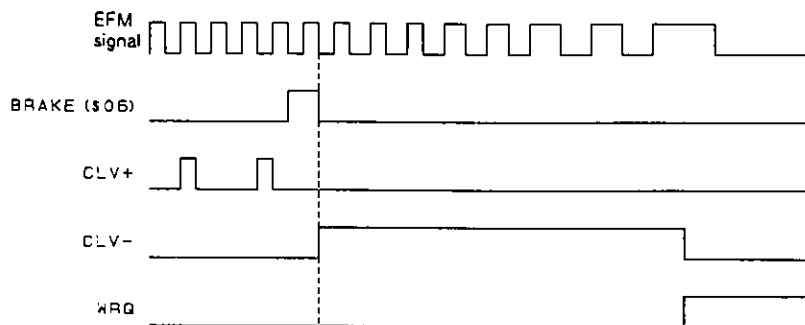

A05888

- Note: 1. If focus is lost during the execution of an internal brake command, the pickup must first be refocussed and then the internal brake command must be reissued.
 2. Since incorrect deceleration state determination is possible depending on the EFM signal playback state (e.g., disk defects, access in progress), we recommend using these functions in combination with a microprocessor.

7. Track Jump Circuit; Pin 15: HFL, pin 16: TES, pin 17: TOFF, pin 18: TGL, pin 19: JP+, pin 20: JP-

- The LC78622E supports the two track count modes listed below.

MSB	LSB	Command	\overline{RES} = low					
0	0	1	0	0	1	0	NEW TRACK COUNT (using the TES/HFL combination)	○
0	0	1	0	0	0	1	STANDARD TRACK COUNT (directly counts the TES signal)	

The earlier track count function uses the TES signal directly as the internal track counter clock. To reduce counting errors resulting from noise on the rising and falling edges of the TES signal, the new track count function prevents noise induced errors by using the combination of the TES and HFL signals, and implements a more reliable track count function. However, dirt and scratches on the disk can result in HFL signal dropouts that may result in missing track count pulses. Thus care is required when using this function.

• TJ commands

MSB	LSB	Command	RES = low
1 0 1 0 0 0 0 0		STANDARD TRACK JUMP	○
1 0 1 0 0 0 0 1		NEW TRACK JUMP	
0 0 0 1 0 0 0 1		1 TRACK JUMP IN #1	
0 0 0 1 0 0 1 0		1 TRACK JUMP IN #2	
0 0 1 1 0 0 0 1		1 TRACK JUMP IN #3	
0 1 0 1 0 0 1 0		1 TRACK JUMP IN #4	
0 0 0 1 0 0 0 0		2 TRACK JUMP IN	
0 0 0 1 0 0 1 1		4 TRACK JUMP IN	
0 0 0 1 0 1 0 0		16 TRACK JUMP IN	
0 0 1 1 0 0 0 0		32 TRACK JUMP IN	
0 0 0 1 0 1 0 1		64 TRACK JUMP IN	
0 0 0 1 0 1 1 1		128 TRACK JUMP IN	
0 0 0 1 1 0 0 1		1 TRACK JUMP OUT #1	
0 0 0 1 1 0 1 0		1 TRACK JUMP OUT #2	
0 0 1 1 1 0 0 1		1 TRACK JUMP OUT #3	
0 1 0 1 1 0 1 0		1 TRACK JUMP OUT #4	
0 0 0 1 1 0 0 0		2 TRACK JUMP OUT	
0 0 0 1 1 0 1 1		4 TRACK JUMP OUT	
0 0 0 1 1 1 0 0		16 TRACK JUMP OUT	
0 0 1 1 1 0 0 0		32 TRACK JUMP OUT	
0 0 0 1 1 1 0 1		64 TRACK JUMP OUT	
0 0 0 1 1 1 1 1		128 TRACK JUMP OUT	
0 0 0 1 0 1 1 0		256 TRACK CHECK	
0 0 0 0 1 1 1 1		TOFF	○
1 0 0 0 1 1 1 1		TON	
1 0 0 0 1 1 0 0		TRACK JUMP BRAKE	
0 0 1 0 0 0 0 1		TOFF OUTPUT MODE DURING JP PULSE PERIOD	○
0 0 1 0 0 0 0 0		RESET TOFF OUTPUT MODE DURING JP PULSE PERIOD	

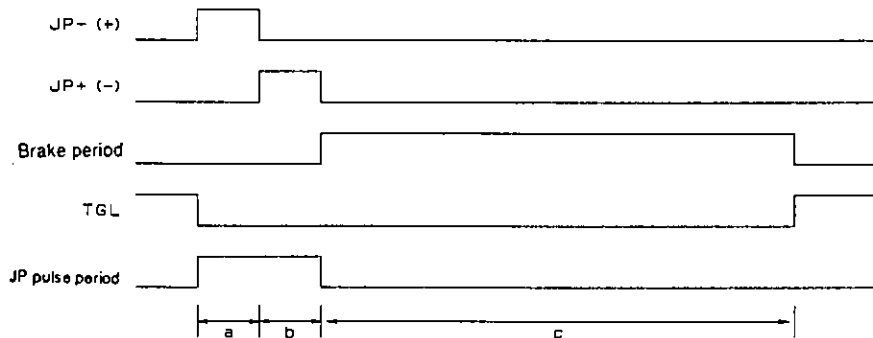

A05889

When the LC78622E receives a track jump instruction as a servo command, it first generates accelerating pulses (period a) and next generates deceleration pulses (period b). The passage of the braking period (period c) completes the specified jump. During the braking period, the LC78622E detects the beam slip direction from the TES and HFL inputs. TOFF is used to cut the components in the TES signal that aggravate slip. The jump destination track is captured by increasing the servo gain with TGL. In during TOFF output mode JP pulse period the TOFF signal is held high during the JP pulse generation period.

Note: Of the modes related to disk motor control, the TOFF pin only goes low in CLV mode, and will be high during accelerate, stop, and decelerate modes. Note that the TOFF pin can be turned on and off independently by microprocessor issued commands. However, this function is only valid when disk motor control is in CLV mode.

• Track jump modes

The table lists the relationships between acceleration pulses (the a period), deceleration pulses (the b period), and the braking period (the c period).

Command	Standard track jump mode			New track jump mode		
	a	b	c	a	b	c
1 TRACK JUMP IN (OUT) #1	233 μ s	233 μ s	60 ms	233 μ s	233 μ s	60 ms
1 TRACK JUMP IN (OUT) #2	0.5 track jump period	233 μ s	60 ms	0.5 track jump period	The same time as "a"	60 ms
1 TRACK JUMP IN (OUT) #3	0.5 track jump period	233 μ s	This period does not exist.	0.5 track jump period	The same time as "a"	This period does not exist.
1 TRACK JUMP IN (OUT) #4	0.5 track jump period	233 μ s	60 ms; TOFF is low during the C period.	0.5 track jump period	The same time as "a"	60 ms; TOFF is low during the C period.
2 TRACK JUMP IN (OUT)	None	None	None	1 track jump period	The same time as "a"	60 ms
4 TRACK JUMP IN (OUT)	2 track jump period	466 μ s	60 ms	2 track jump period	The same time as "a"	60 ms
16 TRACK JUMP IN (OUT)	9 track jump period	7 track jump period	60 ms	9 track jump period	The same time as "a"	60 ms
32 TRACK JUMP IN (OUT)	18 track jump period	14 track jump period	60 ms	18 track jump period	14 track jump period	60 ms
64 TRACK JUMP IN (OUT)	36 track jump period	28 track jump period	60 ms	36 track jump period	28 track jump period	60 ms
128 TRACK JUMP IN (OUT)	72 track jump period	56 track jump period	60 ms	72 track jump period	56 track jump period	60 ms
256 TRACK CHECK	TOFF goes high during the period when 256 tracks are passed over. The a and b pulses are not output.		60 ms	TOFF goes high during the period when 256 tracks are passed over. The a and b pulses are not output.		60 ms
TRACK JUMP BRAKE	There are no a or b periods.		60ms	There are no a and b periods.		60 ms

- Note: 1. As indicated in the table, actuator signals are not output during the 256 TRACK CHECK function. This is a mode in which the TES signal is counted in the tracking loop off state. Therefore, feed motor forwarding is required.
2. The servo command register is automatically reset after one cycle of the track jump sequence (a, b, c) completes.
3. If another track jump command is issued during a track jump operation, the content of that new command will be executed starting immediately.
4. The 1 TRACK JUMP #3 mode does not have a braking period (the C period). Since brake mode must be generated by an external circuit, care is required when using this mode.
5. While there was no braking period (the C period) in the LC78620E/21E for the new track jump command "2 TRACK JUMP IN (OUT)", this has been changed in this LSI, which has a C period of 60 ms.

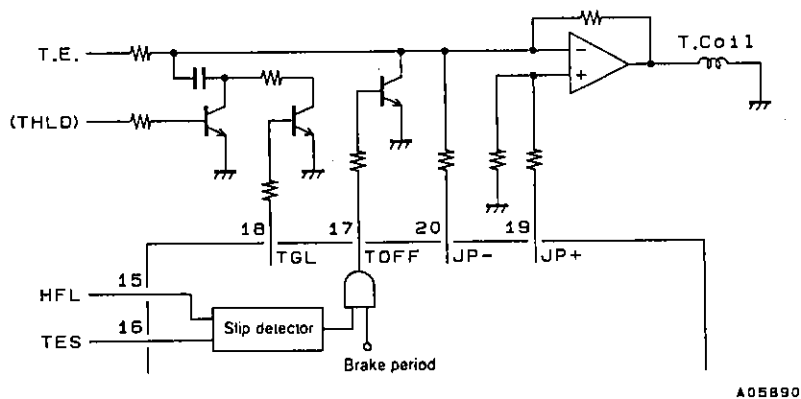

The THLD signal is generated by the LA9230M, LA9231M, or LA9240M, and the tracking signal is held during the JP pulse period.

5. Tracking brake

The chart shows the relationships between the TES, HFL, and TOFF signals during the track jump C period. The TOFF signal is extracted from the HFL signal by TES signal edges. When the HFL signal is high, the pickup is over the mirror surface, and when low, the pickup is over data bits. Thus braking is applied based on the TOFF signal being high when the pickup is moving from a mirror region to a data region and being low when the pickup is moving from a data region to a mirror region.

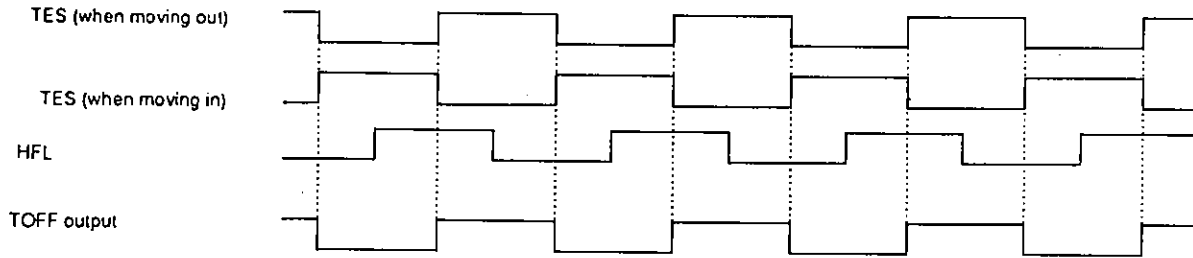

• JP three-value output

MSB	LSB	Command	RES = low							
1	0	1	0	1	1	0	1	0	JP THREE VALUE OUTPUT	
1	0	1	1	0	1	1	1	1	JP TWO VALUE OUTPUT (earlier scheme)	○

The JP three-value output command allows the track jump operation to be controlled from a single pin.

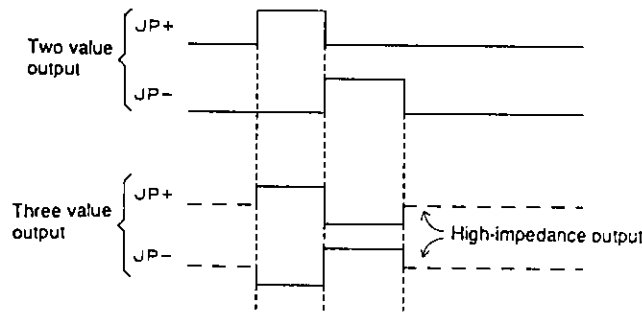

A05892

• Track check mode

MSB	LSB	Command	RES = low							
1	1	1	1	0	0	0	0	0	TRACK CHECK IN	
1	1	1	1	1	0	0	0	0	TRACK CHECK OUT	
1	1	1	1	1	1	1	1	1	TWO BYTE COMMAND RESET	○

The LC78622E will count the specified number of tracks minus one when the microprocessor sends an arbitrary binary value in the range 8 to 254 after issuing either a track check in or a track check out command.

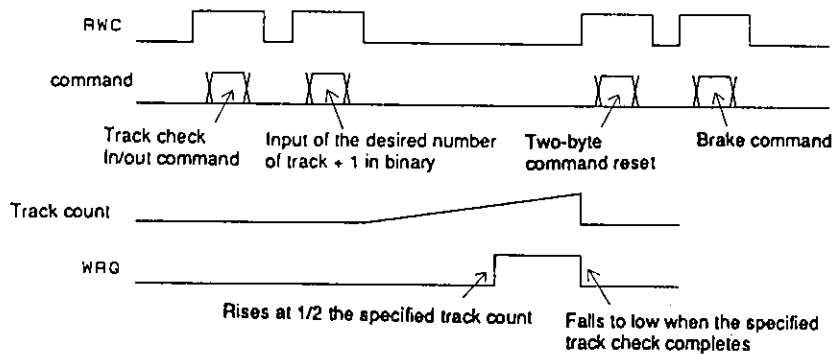

A05893

- Note:
1. When the desired track count has been input in binary, the track check operation is started by the fall of RWC.
 2. During a track check operation the TOFF pin goes high and the tracking loop is turned off. Therefore, feed motor forwarding is required.
 3. When a track check in/out command is issued the function of the WRQ signal switches from the normal mode subcode Q standby monitor function to the track check monitor function. This signal goes high when the track check is half completed, and goes low when the check finishes. The control microprocessor should monitor this signal for a low level to determine when the track check completes.
 4. If a two-byte reset command is not issued, the track check operation will repeat. That is, to skip over 20,000 tracks, issue a track check 201 command once, and then count the WRQ signal 100 times. This will check 20,000 tracks.
 5. After performing a track check operation, use the brake command to have the pickup lock onto the track.

8. Error Flag Output; Pin 48: EFLG, pin 52: FSX

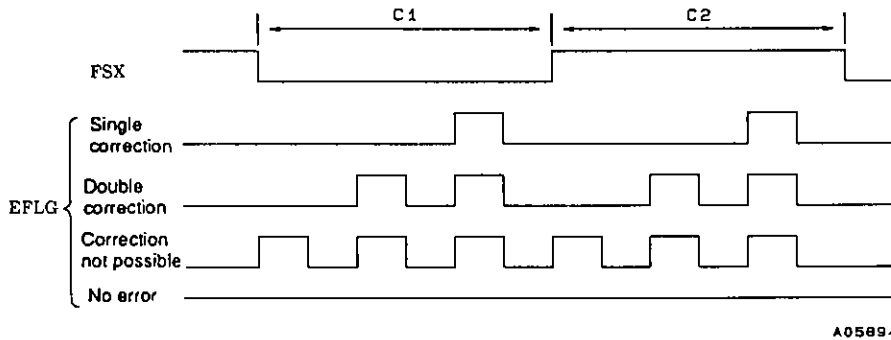

The FSX signal is generated by dividing the crystal oscillator clock, and is a 7.35 kHz frame synchronization signal. The error correction state for each frame is output from EFLG. The FSX low-level period indicates the C1 correction state, and the high-level period indicates the C2 correction state. The playback OK/NG state can be easily determined from the extent of the high level that appears here.

9. Subcode P, Q and R to W Output Circuit; Pin 49: PW, pin 47: SBSY, pin 50: SFSY, pin 51: SBCK
- PW is the subcode signal output pin, and all the codes, P, Q, and R to W can be read out by sending eight clocks to the SBCK pin within 136 μs after the fall of SFSY. The signal that appears on the PW pin changes on the rising edge of SBCK. If a clock is not applied to SBCK, the P code will be output from PW. SFSY is a signal that is output for each subcode frame cycle, and the falling edge of this signal indicates standby for the output of the subcode symbol (P to W). Subcode data P is output on the fall of this signal.

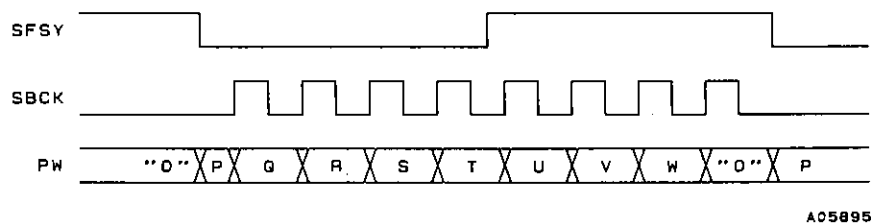

SBSY is a signal output for each subcode block. This signal goes high for the S0 and S1 synchronization signals. The fall of this signal indicates the end of the subcode synchronization signals and the start of the data in the subcode block. (EIAJ format)

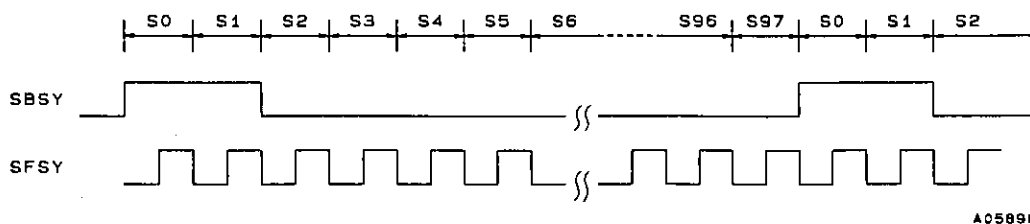

10. Subcode Q Output Circuit Pin 53: WRQ, pin 54: RWC, pin 55: SQOUT, pin 57: \overline{CQCK} , pin 63: \overline{CS}

MSB	LSB	Command	\overline{RES} = low						
0	0	0	0	1	0	0	1	ADDRESS FREE	
1	0	0	0	1	0	0	1	ADDRESS 1	○

Subcode Q can be read from the SQOUT pin by applying a clock to the \overline{CQCK} pin.

Of the eight bits in the subcode, the Q signal is used for song (track) access and display. The WRQ will be high only if the data passed the CRC error check and the subcode Q format internal address is 1*. The control microprocessor can read out data from SQOUT in the order shown below by detecting this high level and applying \overline{CQCK} . When \overline{CQCK} is applied the DSP disables register update internally. The microprocessor should give update permission by setting RWC high briefly after reading has completed. WRQ will fall to low at this time. Since WRQ falls to low 11.2 ms after going high, \overline{CQCK} must be applied during the high period. Note that data is read out in an LSB first format.

Note: * That state will be ignored if an address free command is input. This is provided to handle CD-ROM applications.

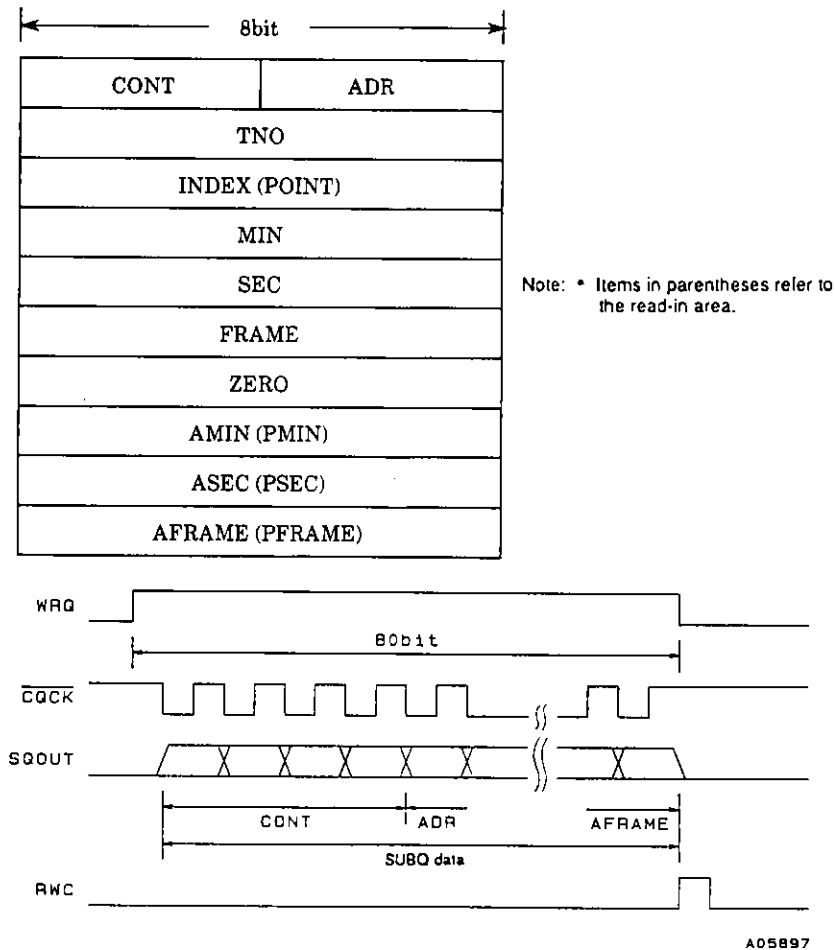

- Note: 1. Normally, the WRQ pin indicates the subcode Q standby state. However, it is used for a different monitoring purpose in track check mode and during internal braking. (See the items on track counting and internal braking for details.)
2. The LC78622E becomes active when the \overline{CS} pin is low, and subcode Q data is output from the SQOUT pin. When the \overline{CS} pin is high, the SQOUT pin goes to the high-impedance state.

11. Bilingual Function

MSB	LSB	Command	RES = low
0 0 1 0 1 0 0 0		STO CONT	○
0 0 1 0 1 0 0 1		Lch CONT	
0 0 1 0 1 0 1 0		Rch CONT	

- Following a reset or when a stereo (28H) command has been issued, the left and right channel data is output to the left and right channels respectively.
- When an Lch set (29H) command is issued, the left and right channels both output the left channel data.
- When an Rch set (2AH) command is issued, the left and right channels both output the right channel data.

12. De-Emphasis; Pin 29: EMPH

The preemphasis on/off bit in the subcode Q control information is output from the EMPH pin. When this pin is high, the LC78622E internal de-emphasis circuit operates and the digital filters and the D/A converter output de-emphasized data.

13. Digital Attenuator

Digital attenuation can be applied to the audio data by setting the RWC pin high and inputting the corresponding two-byte command to the COIN pin in synchronization with the CQCK clock.

MSB	LSB	Command	RES = low
1 0 0 0 0 0 0 1		ATT DATA SET	▶ DATA 00H set (MUTE $-\infty$ dB)
1 0 0 0 0 0 1 0		ATT 4 STEP UP	
1 0 0 0 0 0 1 1		ATT 4 STEP DOWN	
1 0 0 0 0 1 0 0		ATT 8 STEP UP	
1 0 0 0 0 1 0 1		ATT 8 STEP DOWN	
1 0 0 0 0 1 1 0		ATT 16 STEP UP	
1 0 0 0 0 1 1 1		ATT 16 STEP DOWN	

• Attenuation setup

Since the attenuation level is set to the muted state (a muting of $-\infty$ is specified by an attenuation coefficient of 00H) after the attenuation level is reset, the attenuation coefficient must be directly set to EEH (using the ATT DATA SET command) to output audio signals. Note that the attenuation level can be set to one of 239 values from 00H to EEH.

These two-byte commands differ from the two-byte commands used for track counting in that it is only necessary to set RWC once and a two-byte command reset is not required. After inputting the target attenuation level as a value in the range 00H to EEH, sending an attenuator step up/down command will cause the attenuation level to approach the target value in steps of 4, 8, or 16 units as specified in synchronization with rising edges on the LRSY input. However, the ATT DATA SET command sets the target value directly. If a new data value is input during the transition, the value begins to approach the new target value at that point. Note that the UP/DOWN distinction is significant here.

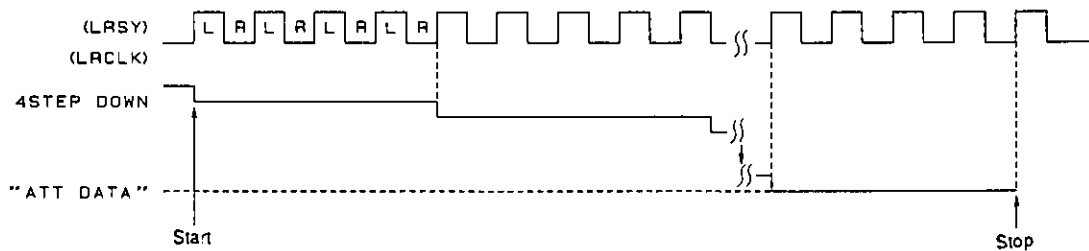

A05898

$$\text{Audio output level} = 20 \log \frac{\text{ATT DATA}}{100\text{H}} [\text{dB}]$$

For example, the formula below calculates the time required for the attenuation level to increase from 00H to EEH when a 4STEP UP command is executed. Note that the control microprocessor must provide enough of a time margin for this operation to complete before issuing the next attenuation level set command.

$$\frac{238 \text{ level} \times 4\text{STEP UP}}{44.1 \text{ kHz}} \approx 21.6 \text{ ms}$$

Note: Setting the attenuation level to values of EFH or higher is disallowed to prevent overflows in one-bit D/A converter calculations from causing noise.

14. Mute Output; Pin 35: MUTEL, pin 42: MUTER

15. C2 Flag Output; Pin 30: C2F
C2F output flag information in 8-bit units.

16. Digital Output Circuit; Pin 31: DOUT

This is an output pin for use with a digital audio interface. Data is output in the EIAJ format. This signal has been processed by the interpolation and muting circuits. This pin has a built-in driver circuit and can directly drive a transformer.

MSB	LSB	Command	RES = low
0	1 0 0 0 0 1 0	DOUT ON	○
0	1 0 0 0 0 1 1	DOUT OFF	
0	1 0 0 0 0 0 0	UBIT ON	○
0	1 0 0 0 0 0 1	UBIT OFF	
1	0 0 0 1 0 0 0	CDROM-XA	
1	0 0 0 1 0 1 1	ROMXA-RST	○

- The DOUT pin can be locked at the low level by issuing a DOUT OFF command.
- The UBIT information in the DOUT data can be locked at zero by issuing a UBIT OFF command.
- The DOUT data can be switched to data for which interpolation and muting processing have not been performed by issuing a CD-ROM XA command.

17. Mute Control Circuit

MSB	LSB	Command	RES = low
0	0 0 0 0 0 0 1	MUTE: 0 dB	
0	0 0 0 0 0 1 1	MUTE: -∞ dB	○

Inputting the above command mutes the audio level (MUTE -∞ dB). Since zero-cross muting is used, there is very little noise associated with this operation. The IC defines zero cross to be the ranges where the upper 7 bits of the data are all zeros or all ones. Note that the MUTE -12 dB instruction supported by the LC78620E has been removed from this product.

18. Interpolation Circuit

Outputting incorrect audio data that could not be corrected by the error detection and correction circuit would result in loud noises being output. To minimize this noise, the LC78622E replaces the incorrect data with linearly interpolated data based on the correct data on either side of the incorrect data. If one set of C2 flags indicate errors, the above replacement is performed, and if two or more sets of C2 flags indicate errors, the IC holds the previous value. However, when correct data is output following two or more consecutive C2 flags indicating errors, the data point between the correct data and the data output two points previously (the held value) is replaced with a value computed by linearly interpolating those two values.

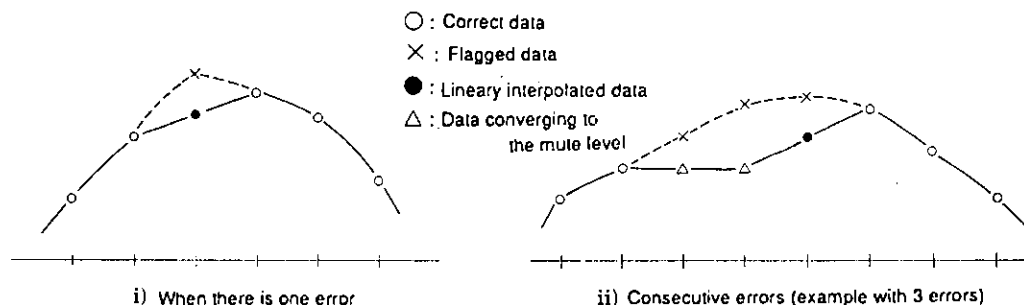

19. General-Purpose I/O Ports; Pin 24: CONT1, Pin 25: CONT2, Pin 26: CONT3, Pin 27: CONT4, Pin 28: CONT5
 The LC78622E provides the five CONT1 to CONT5 I/O ports. These are all set to function as input pins after a reset. Unused port pins should be either connected to ground or set to the output port function.

MSB	LSB	Command	RES = low
1	1 0 1 1 1 0 1	PORT READ	
1	1 0 1 1 0 1 1	PORT OP-E/D SET	PORT I SET
1	1 0 1 1 1 0 0	PORT DATA SET	

Port data is read in by the PORT READ command in synchronization with the falling edge of the \overline{CQCK} pin by the SQOUT pin in the order CONT1 to CONT5. This command is a single-byte command.

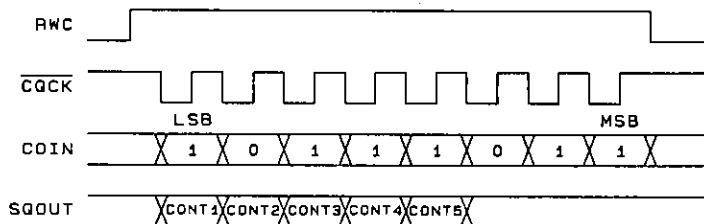

Additionally, these ports can be set up individually to function as control output pins with the PORT OP-E/D SET command. The ports are selected using the lower 5 bits of the 1Byte data. The bits in the data correspond to CONT1 to CONT5 in order starting with the LSB of the 1Byte data. This command is a Two-byte command. (RWC set once)

MSB	LSB	Command
1	1 0 1 1 0 1 1 X X X d5 d4 d3 d2 d1	PORT OP-E/D SET

- dn = 1 ... Sets CONTn to be an output pin
- dn = 0 ... Sets CONTn to be an input pin
- X... don't care

Ports set to be output pins can output high or low levels independently. The lower 5 bits of the 1 Byte data correspond to those ports. The bits in the data correspond to CONT1 to CONT5 in order starting with the LSB of the 1 Byte data. This command is a two-byte command. (RWC set once)

MSB	LSB	Command
1 1 0 1 1 1 0 0	X X X d5 d4 d3 d2 d1	PORT DATA SET

dn = 1 ... Sets CONTn to be an output pin
 dn = 0 ... Sets CONTn to be an input pin
 X... don't care

20. Clock Oscillator; Pin 45: X_{IN}, pin 44: X_{OUT}

MSB	LSB	Command	\overline{RES} = low
1 0 0 0 1 1 1 0		OSC ON	○
1 0 0 0 1 1 0 1		OSC OFF	○
1 1 0 0 1 1 1 0		XTAL 16M	○
1 1 0 0 0 0 1 0		NORMAL-SPEED PLAYBACK	○
1 1 0 0 0 0 0 1		DOUBLE-SPEED PLAYBACK	○

The clock that is used as the time base is generated by connecting a 16.9344 MHz oscillator element between these pins. The OSC OFF command turns off both the VCO and crystal oscillators. The system control microprocessor can issue double-speed or normal-speed playback command when the application implements double-speed playback

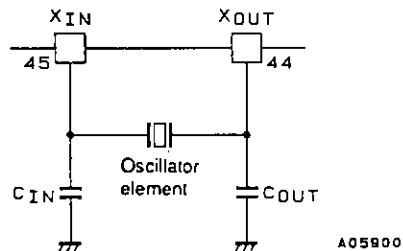

21. 16M and 4.2M Pins; Pin 60: 16M, pin 61: 4.2M

Both in normal- and double-speed playback modes, the 16M pin buffer outputs the 16.9344 MHz external crystal oscillator 16.9344 MHz signal. The 4.2M pin supplies the LA9230M, LA9231M or LA9240M system clock, normally outputting a 4.2336 MHz signal. When the oscillator is turned off both these pins will be fixed at either high or low.

LC78622E

22. Reset Circuit; Pin 58: $\overline{\text{RES}}$

When power is first applied, this pin should be briefly set low and then set high. This will set the muting to $-\infty$ dB and stop the disk motor.

Constant linear velocity servo	START	<input type="checkbox"/> STOP	BRAKE	CLV
Muting control	0 dB	<input type="checkbox"/> $-\infty$		
Q subcode address conditions	<input type="checkbox"/> Address 1	Address free		
Track jump mode	<input type="checkbox"/> Standard	New		
Track count mode	Standard	<input type="checkbox"/> New		
Digital attenuator	<input type="checkbox"/> DATA 0	DATA 00H to EEH		
OSC	<input type="checkbox"/> ON	OFF		
Playback speed	<input type="checkbox"/> Normal speed	Double speed		
Digital filter normal speed	ON	<input type="checkbox"/> OFF		

Setting the $\overline{\text{RES}}$ pin low sets the LC78622E to the settings enclosed in boxes in the table.

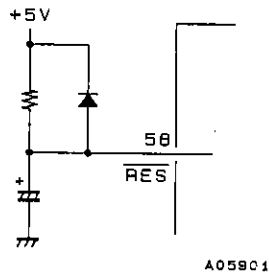

23. Other Pins; Pin 2: TAI, pin 64: TEST1, pin 11: TEST2, pin 32: TEST3, pin 33: TEST4, pin 62: TEST5, pin 59: TST11

These pins are used for testing the LSI's internal circuits. Even though pull-down resistors are built into the TAI and TEST2 to TEST5 input pin circuits, these pins must be connected to 0 V during normal operation. TST11 is an output pin and should normally be left open.

24. Circuit Block Operating Descriptions

• RAM address control

The LC78622E incorporates an 8-bit × 2k-word RAM on chip. This RAM has an EFM demodulated data jitter handling capacity of ±4 frames implemented using address control. The LC78622E continuously checks the remaining buffer capacity and controls the data write address to fall in the center of the buffer capacity by making fine adjustments to the frequency divisor in the PCK side of the CLV servo circuit. If the ±4 frame buffer capacity is exceeded, the LC78622E forcibly sets the write address to the ±0 position. However, since the errors that occur due to this operation cannot be handled with error flag processing, the IC applies muting to the output for a 128 frame period.

Position	Division ratio or processing	
-4 or less	Force to ±0	
-3	589	Increase ratio
-2	589	
-1	589	
±0	588	Standard ratio
+1	587	Decrease ratio
+2	587	
+3	587	
+4 or more	Force to ±0	

• C1 and C2 Error Correction

The LC78622E writes EFM demodulated data to internal RAM to compensate for jitter and then performs the following processing with uniform timing based on the crystal oscillator clock. First, the LC78622E performs C1 error checking and correction in the C1 block, determines the C1 flags, and writes the C1 flag register. Next, the LC78622E performs C2 error checking and correction in the C2 block, determines the C2 flags, and writes data to internal RAM.

C1 flag	Error correction and flag processing
No errors	No correction required · Flag reset
1 error	Correction · Flag reset
2 errors	Correction · Flag set
3 errors or more	Correction not possible · Flag set

C2 flag	Error correction and flag processing
No errors	No correction required · Flag reset
1 error	Correction · Flag reset
2 errors	Depends on C1 flags ^{*1}
3 errors or more	Depends on C1 flags ^{*2}

- Note: 1. If the positions of the errors determined by the C2 check agree with those specified by the C1 flags, the correction is performed and the flags are cleared. However, if the number of C1 flags is 7 or higher, C2 correction may fail. In this case correction is not performed and the C1 flags are taken as the C2 flags without change. Error correction is not possible if one error position agrees and the other does not. Furthermore, if the number of C1 flags is 5 or under, the C1 check result can be seen as unreliable. Accordingly, the flags will be set in this case. Cases where the number of C1 flags is 6 or more are handled in the same way, and the C1 flags are taken as the C2 flags without change. When there is not even one agreement between the error positions, error correction is, of course, impossible. Here, if the number of C1 flags was 2 or under, data that was seen as correct after C1 correction is now seen as incorrect data. The flags are set in this case. In other cases, the C1 flags are taken as the C2 flags without change.
2. When data is determined to have three or more errors and be uncorrectable, correction is, of course, impossible. Here, if the number of C1 flags was 2 or under, data that was seen as correct after C1 correction is now seen as incorrect data. The flags are set in this case. In other cases the C1 flags are taken as the C2 flags without change

LC78622E

25. Command Summary Table

Blank entry: Illegal command, #: Changed or added command, *: Latching commands (mode setting commands), O: Commands shared with an ASP (LA9220M/30M/31M or other processor), Items in parentheses are ASP commands (provided for reference purposes)

00000000	(ADJ.reset)	00100000	* TOFF low in TJ mode	01000000	* UBIT ON	01100000	
00000001	* MUTE 0 dB	00100001	* TOFF high in TJ mode	01000001	* UBIT OFF	01100001	
00000010	#	00100010	* New TRACK COUNT	01000010	* DOUT ON	01100010	
00000011	* MUTE -∞ dB	00100011	* Old TRACK COUNT	01000011	* DOUT OFF	01100011	
00000100	* DISC MTR START	00100100		01000100		01100100	
00000101	* DISC MTR CLV	00100101		01000101		01100101	
00000110	* DISC MTR BRAKE	00100110		01000110		01100110	
00000111	* DISC MTR STOP	00100111		01000111		01100111	
00001000	O FOCUS START #1	00101000	* STO CONT	01001000		01101000	
00001001	* ADDRESS FREE	00101001	* LCH CONT	01001001		01101001	
00001010	#	00101010	* RCH CONT	01001010		01101010	
00001011		00101011	#	01001011		01101011	#
00001100		00101100	#	01001100		01101100	#
00001101		00101101	#	01001101		01101101	
00001110	#	00101110	#	01001110		01101110	*DF normal speed off
00001111	* TRACKING OFF	00101111		01001111		01101111	#
00010000	2TJ IN	00110000	32TJ IN	01010000		01110000	
00010001	1TJ IN #1	00110001	1TJ IN #3	01010001		01110001	
00010010	1TJ IN #2	00110010		01010010	1TJ IN #4	01110010	
00010011	4TJ IN	00110011		01010011		01110011	
00010100	16TJ IN	00110100		01010100		01110100	
00010101	64TJ IN	00110101		01010101		01110101	
00010110	256TC	00110110		01010110		01110110	
00010111	128TJ IN	00110111		01010111		01110111	
00011000	2TJ OUT	00111000	32TJ OUT	01011000		01111000	
00011001	1TJ OUT #1	00111001	1TJ OUT #3	01011001		01111001	
00011010	1TJ OUT #2	00111010		01011010	1TJ OUT #4	01111010	
00011011	4TJ OUT	00111011		01011011		01111011	
00011100	16TJ OUT	00111100		01011100		01111100	
00011101	64TJ OUT	00111101		01011101		01111101	
00011110		00111110		01011110		01111110	
00011111	128TJ OUT	00111111		01011111		01111111	

Continued on next page.

LC78622E

Continued from preceding page.

Blank entry: Illegal command, #: Changed or added command, *: Latching commands (mode setting commands), O: Commands shared with an ASP (LA9220M/30M/31M or other processor), Items in parentheses are ASP commands (provided for reference purposes)

10000000		10100000	* Old TRK JMP	11000000		11100000	
10000001	* ATT DATA SET	10100001	* New TRK JMP	11000001	* Double-speed playback	11100001	
10000010	* ATT 4STP UP	10100010	FOCUS START #2	11000010	* Normal-speed playback	11100010	
10000011	* ATT 4STP DWN	10100011	* Internal BRAKE CONT	11000011		11100011	
10000100	* ATT 8STP UP	10100100		11000100	* Internal BRK OFF	11100100	
10000101	* ATT 8STP DWN	10100101		11000101	* Internal BRK ON	11100101	
10000110	* ATT 16STP UP	10100110		11000110		11100110	
10000111	* ATT 16STP DWN	10100111		11000111		11100111	
10001000	* #CDROMXA	10101000	* DISC 8 SET	11001000	#	11101000	
10001001	* ADDRESS 1	10101001	* DISC 12 SET	11001001	*#	11101001	
10001010	#	10101010		11001010	* Internal BRK-DMC low	11101010	
10001011	* #ROMXA RST	10101011		11001011	* Internal BRK-DMC high	11101011	
10001100	TRACK JMP BRK	10101100	*VCO X2 SET	11001100	* TOFF during Internal BRAKE	11101100	
10001101	* OSC OFF	10101101	*VCO X1 SET	11001101	* TON during Internal BRAKE	11101101	
10001110	* OSC ON	10101110		11001110	* Xtal 16M	11101110	* Command noise rejecter OFF
10001111	* TRACKING ON	10101111		11001111		11101111	* Command noise rejecter ON
10010000	(* F.OFF.ADJ.ST)	10110000	* CLV-PH 1/1 mode	11010000		11110000	* O TRCK CHECK IN (2BYTE DETECT)
10010001	(* F.OFF.ADJ.OFF)	10110001	* CLV-PH 1/2 mode	11010001		11110001	
10010010	(* T.OFF.ADJ.ST)	10110010	* CLV-PH 1/4 mode	11010010		11110010	
10010011	(* T.OFF.ADJ.OFF)	10110011	* CLV-PH 1/8 mode	11010011		11110011	
10010100	(* LSR.ON)	10110100	* CLV3ST output ON	11010100		11110100	
10010101	(* LSR.OF/F.SV.ON)	10110101	* CLV3ST output OFF	11010101		11110101	
10010110	(* LSR.OF/F.SV.OF)	10110110	* JP3ST output ON	11010110		11110110	
10010111	(* SP.8CM)	10110111	* JP3ST output OFF	11010111		11110111	
10011000	(* SP.12CM)	10111000		11011000		11111000	* O TRCK CHECK OUT (2BYTE DETECT)
10011001	(* SP.OFF)	10111001		11011001		11111001	
10011010	(* SLED.ON)	10111010		11011010		11111010	
10011011	(* SLED.OFF)	10111011		11011011	#PORT OP-ED SET	11111011	
10011100	(* EF.BAL.START)	10111100		11011100	#PORT DATA SET	11111100	
10011101	(* T.SERVO.OFF)	10111101		11011101	#PORT READ	11111101	
10011110	(* T.SERVO.ON)	10111110		11011110		11111110	O NOTHING
10011111		10111111		11011111		11111111	* O 2BYTE CMD RST

Note: VCO x 2 SET command should be issued in case of low voltage power supply application.

LC78622E

26. Sample Application Circuit

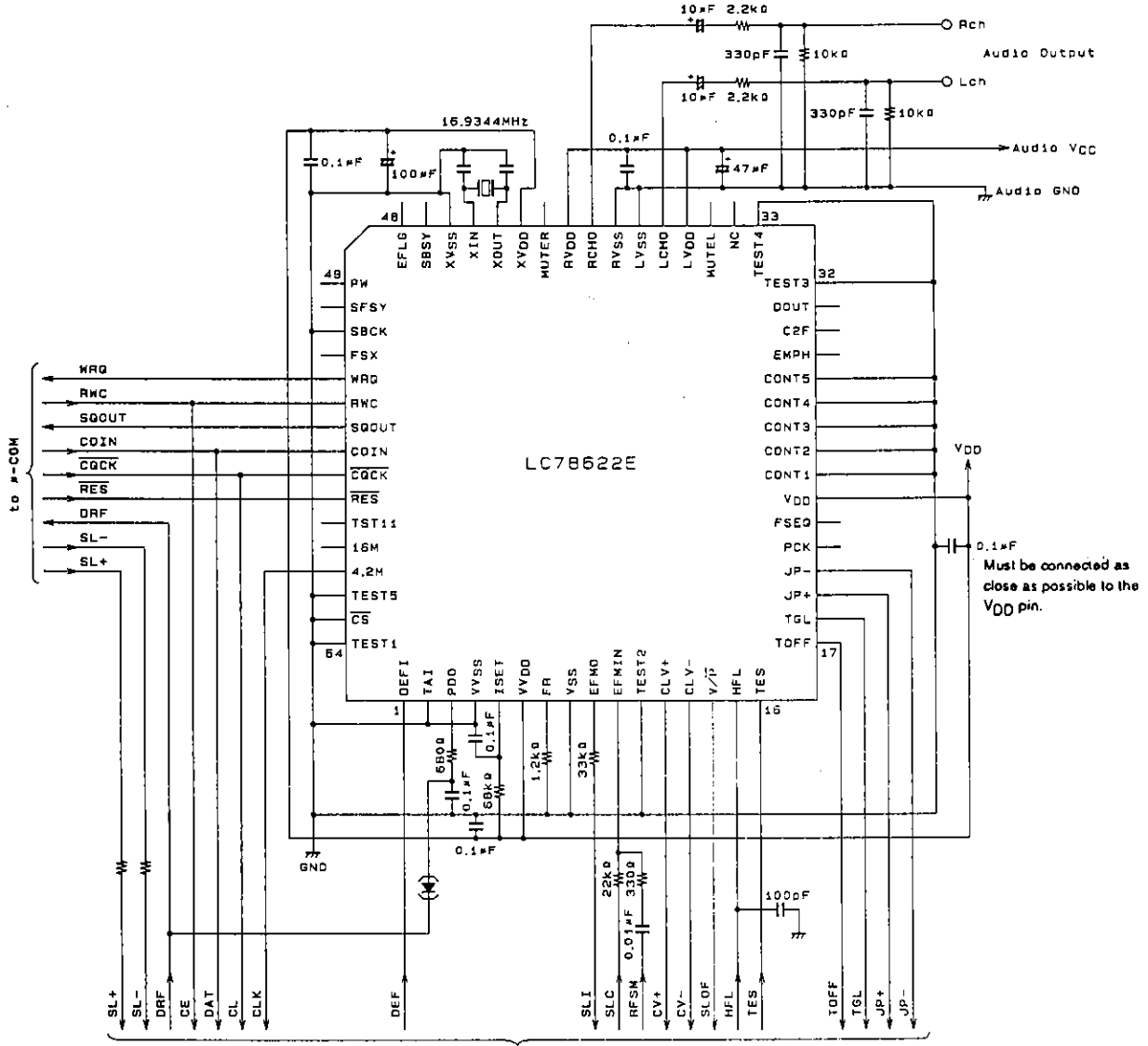

to LA9240N

405902

27. CD-DSP Functional Comparison

Product Function	LC7860KA	LC7861NE → LC7861KE	LC7867E	LC7868E → LC7868KE	LC7869E	LC78681E → LC78681KE	LC78620E	LC78622E
	When paired with an analog ASP	When paired with an analog ASP	When paired with an analog ASP	When paired with an analog ASP	When paired with an analog ASP	When paired with an analog ASP	Built-in VCO	Built-in VCO
16 KRAM	External	○	○	○	○	○	○	○
Speed	st	2X/4X	2X	st/4X	st	2X/4X	2X	2X
Digital output	X	○	○	○	○	○	○	○
Interpolation	2	4	4	4	4	4	4	2
Zero-cross muting	X	○	○	○	○	○	○	○
Level meter peak search	X	X	X	○	○	○	○	X
Bilingual	X	X	X	○	○	○	○	○
Digital attenuator	X	X	X	X	X	X	○	○
Digital filters	○	○	○	○	○	○	○	○
	—	—	—	○	—	—	—	○
	—	—	—	—	○	—	○	—
Digital de-emphasis	X	X	X	○	○	X	○	○
1 bit D/A converter	X	X	X	X	X	X	○	○
Lowpass filter	X	X	X	X	X	X	X	○

- No products described or contained herein are intended for use in surgical implants, life-support systems, aerospace equipment, nuclear power control systems, vehicles, disaster/crime-prevention equipment and the like, the failure of which may directly or indirectly cause injury, death or property loss.
- Anyone purchasing any products described or contained herein for an above-mentioned use shall:
 - ① Accept full responsibility and indemnify and defend SANYO ELECTRIC CO., LTD., its affiliates, subsidiaries and distributors and all their officers and employees, jointly and severally, against any and all claims and litigation and all damages, cost and expenses associated with such use:
 - ② Not impose any responsibility for any fault or negligence which may be cited in any such claim or litigation on SANYO ELECTRIC CO., LTD., its affiliates, subsidiaries and distributors or any of their officers and employees jointly or severally.
- Information (including circuit diagrams and circuit parameters) herein is for example only; it is not guaranteed for volume production. SANYO believes information herein is accurate and reliable, but no guarantees are made or implied regarding its use or any infringements of intellectual property rights or other rights of third parties.

This catalog provides information as of September, 1996. Specifications and information herein are subject to change without notice.