

**VIDEO AND SOUND IF SYSTEM
WITH AUDIO AND VIDEO SWITCHES**

PRELIMINARY DATA

- VIDEO PLL DEMODULATION
- SOUND PLL DEMODULATION
- POSITIVE AND NEGATIVE MODULATION
- AGC FOR BG AND L STANDARDS
- AUDIO SWITCH
- DC VOLUME CONTROL
- VIDEO SWITCH

DESCRIPTION

The STV8224 is a picture and sound IF processor for multistandard application with very few external components and adjustments.

It provides the audio and video switches for one SCART plug application.

AM sound demodulation is performed with the STV8225 add-on.

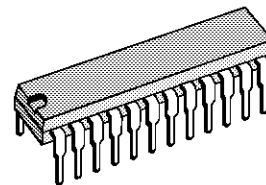

SHRINK24
(Plastic Package)

ORDER CODE : STV8224

PIN CONNECTIONS

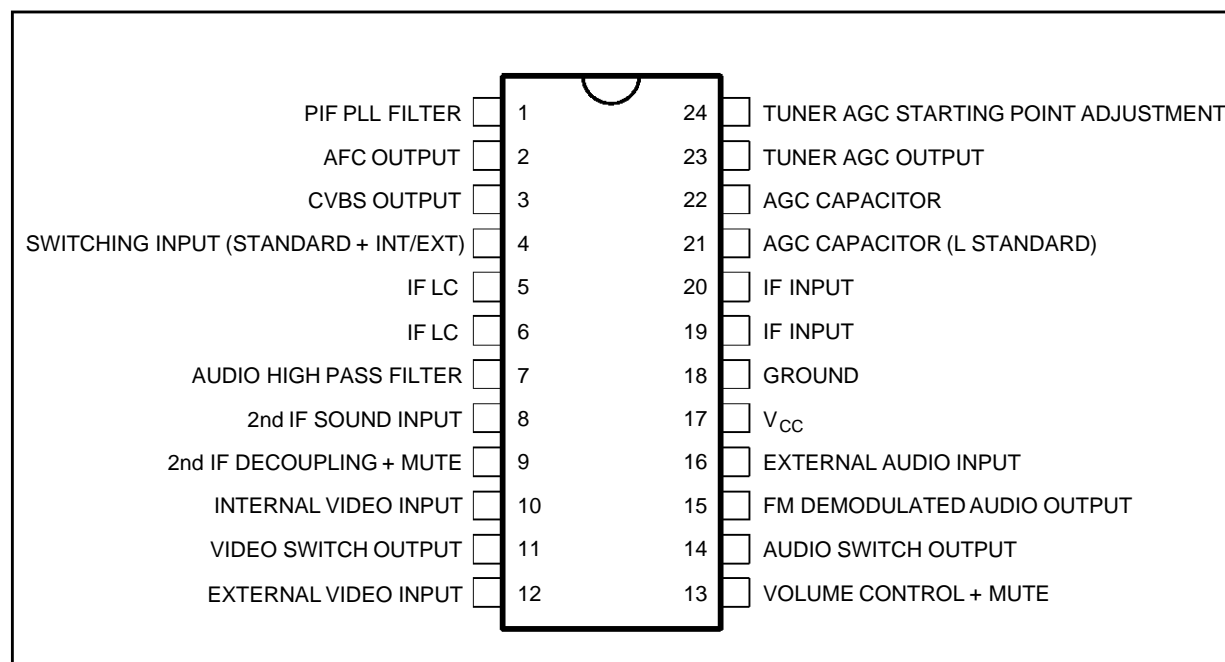

8224-01.EPS

STV8224

BLOCK DIAGRAM

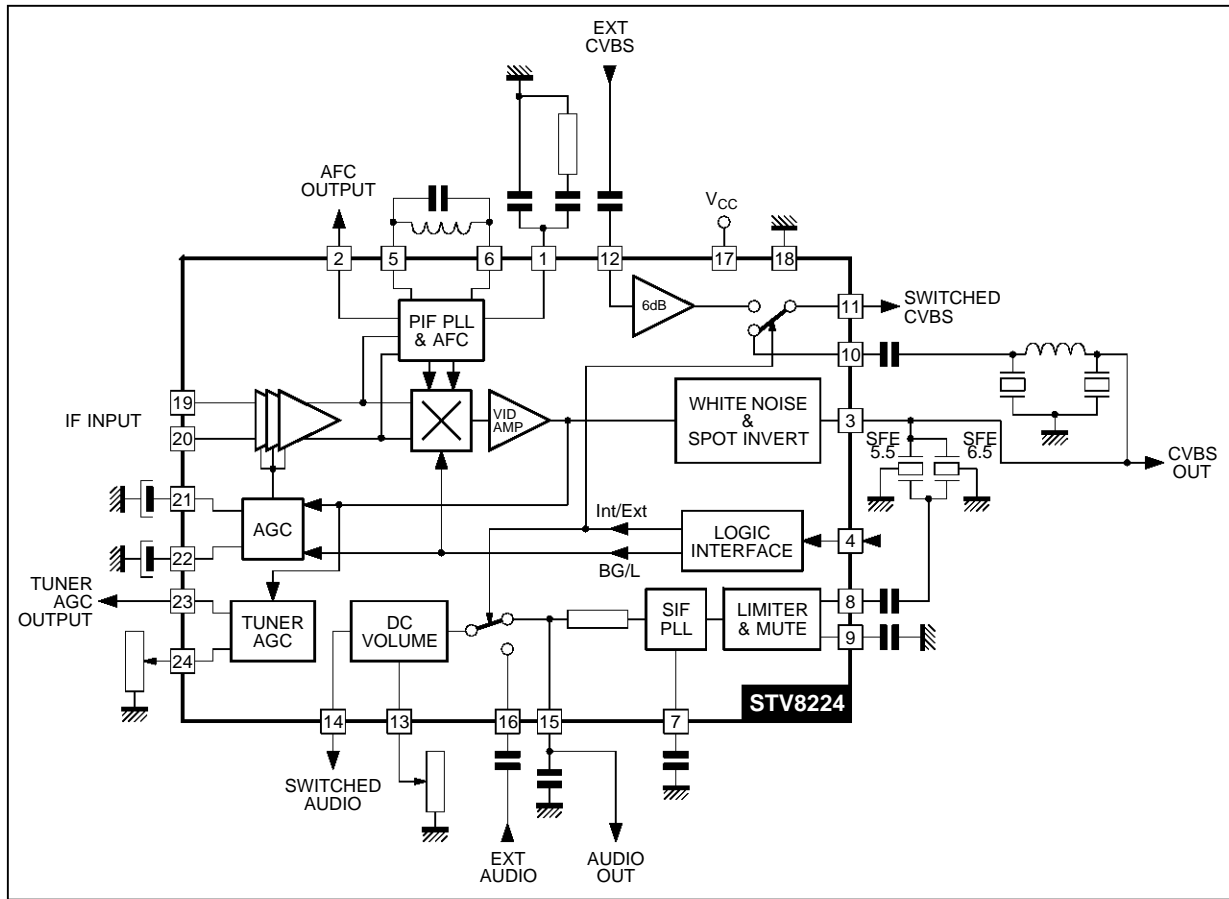

8224-02.EPS

ABSOLUTE MAXIMUM RATINGS

Symbol	Parameter	Value	Unit
V_S	Supply Voltage	13.5	V
V_x	Tuner AGC Voltage	V_{CC}	V
T_{stg}	Storage Temperature	-40, +150	$^{\circ}C$
T_{oper}	Operating Temperature	0, +70	$^{\circ}C$

8224-01.TBL

THERMAL DATA

Symbol	Parameter	Value	Unit
$R_{th(j-a)}$	Junction-ambient Thermal Resistance	Max. 75	$^{\circ}C/W$

8224-02.TBL

ELECTRICAL CHARACTERISTICS

($T_{amb} = 25^{\circ}\text{C}$, $V_{CC} = 9\text{V}$, IF input = 10mV_{RMS} sync level at B/G, Peak-white level at L, Video modulation DSB, $D = 90\%$ at B/G, $D = 100\%$ at L, $f_{PC} = 38.9\text{MHz}$, $f_{SC} = 33.4\text{MHz}$, Video BW = 5MHz , Sound carrier input : 5.5MHz , 10mV_{RMS} , $f_M = 1\text{kHz}$, Audio BW = 20kHz , $\Delta f = \pm 50\text{kHz}$, Volume attenuation = 0dB , unless otherwise specified)

Symbol	Parameter	Test Conditions	Min.	Typ.	Max.	Unit
--------	-----------	-----------------	------	------	------	------

SUPPLY

V_{CC}	Voltage Operating		8	9	12.6	V
I_{CC}	Supply Current	I_{17} , $V_{CC} = 9\text{V}$		70	95	mA

IF AMPLIFIER

V_{19-20}	Input Sensitivity (RMS)	-3dB Video at Output		70		μV_{RMS}
R_{19-20}	Differential Input Resistance			1.5		$\text{k}\Omega$
C_{19-20}	Differential Input Capacitance			2		pF
Gr	Gain Control Range			64		dB
	Max Input Signal	+1dB Video at Output		110		mV_{RMS}

AFC

	AFC Slope			0.2		$\mu\text{A}/\text{kHz}$
--	-----------	--	--	-----	--	--------------------------

DEMODULATED VIDEO OUTPUT (Pin 3)

V_{A3}	Amplitude	Top Sync to White	2	2.3	2.6	V_{PP}
BG vs L	Amplitude Difference				10	%
V_{S3}	Top Sync Level	B/G and L	1.6	1.9	2.2	V
	Zero Carrier Level	B/G L		4.3 1.9		V V
BW	Bandwidth	-3dB Video Signal		9		MHz
Dg	Differential Gain			3	7	%
Dp	Differential Phase			3	7	Degree
V_{r3}	Residual Carrier Signal (RMS Value)			1	10	mV
V_{r3}	Residual 2nd Harmonic (RMS Value)			1	10	mV
I_3	Internal Bias of Emitter Follower		3	5		mA
S/N	Signal to Noise Ratio	Note 1		55		dB
	Intermodulation 1.07MHz	Note 2		50		dB
V_{WTH}	White Noise Threshold Voltage			4.6		V
V_{WIL}	White Noise Insertion Level			3.3		V
V_{BTH}	Black Noise Threshold Voltage			1.3		V
V_{BIL}	Black Noise Insertion Level			2.5		V

AGC CIRCUIT (BG MODE)

I_{22C}	Charging Current		550	950	1300	μA
I_{22D}	Discharge Current		12	20	28	μA
C/D	Charging/Discharging Ratio			45		

Notes : 1. $\frac{S}{N} = 20 \log 10 \frac{V_{out \text{ black white}}}{V_N (\text{mV}_{RMS})}$ at BW = 5MHz

2. Video carrier relative level = 0dB , Chroma subcarrier level = -3.2dB , Sound carrier relative level = -20dB

8224-03.TBL

STV8224

ELECTRICAL CHARACTERISTICS (continued)

($T_{amb} = 25^{\circ}\text{C}$, $V_{CC} = 9\text{V}$, IF input = 10mV_{RMS} sync level at B/G, Peak-white level at L, Video modulation DSB, $D = 90\%$ at B/G, $D = 100\%$ at L, $f_{PC} = 38.9\text{MHz}$, $f_{SC} = 33.4\text{MHz}$, Video BW = 5MHz , Sound carrier input : 5.5MHz , 10mV_{RMS} , $f_M = 1\text{kHz}$, Audio BW = 20kHz , $\Delta f = \pm 50\text{kHz}$, Volume attenuation = 0dB , unless otherwise specified)

Symbol	Parameter	Test Conditions	Min.	Typ.	Max.	Unit
--------	-----------	-----------------	------	------	------	------

AGC CIRCUIT (L MODE)

I_{22C}	Charging Current	Note 3		3.3		mA
I_{22D}	Discharge Current (Frame Sampled)			40		μA
	Additional Charging Current (Frame Sampled)	L in case of missing, VITS Pulses and no White in Video Content		180		μA
	Threshold Voltage Level	L in case of missing, VITS Pulses and no White in Video Content		$V_{Black} + 0.1$		V

TUNER AGC

I_{23}	Sinked Current		1.4	2.1	2.8	mA
S23	Current Slope	$R = 3\text{k}\Omega$ on Pin 24		300		$\mu\text{A}/\text{dB}$

FM SOUND DEMODULATION

V_{8S}	Input Sensitivity	-3dB FM detected signal		60		μV
R_8	Limiter Input Resistance			1.2		$\text{k}\Omega$
AMR	Amplitude Modulation Rejection	Note 4	40	53		dB
SVR	Supply Voltage Rejection Ratio			TBF		dB
V_{15}	Detected Audio Output Signal			1		V_{RMS}
THD	Total Harmonic Distortion			0.2	1	%
R_{15}	Internal Deemphasis Resistor		600	750	900	Ω
S/N	Signal to Noise Ratio	Note 5, Weighted CCIR 468-4		55		dB

VOLUME CONTROL

V_C Range	Control Range			80		dB
-------------	---------------	--	--	----	--	----

AUDIO SWITCH

R_{16}	Input Resistance		40	65		$\text{k}\Omega$
CRtk	Crosstalk		70	80		dB
EXTHD	THD on External Signal	$V_{IN} = 2\text{V}_{RMS}$, Attenuation = 0dB		0.05	0.3	%

Notes : 3. Triggered on white level

4. $AMR = 20 \log \frac{V_{15} (\text{mV}_{RMS})}{V_{AM}}$ (dB) where V_{AM} = output amplitude in AM for $f_M = 1\text{kHz}$ and $m = 30\%$

5. $\frac{S}{N} = 20 \log \frac{V_{15} (\text{mV}_{RMS})}{V_N (\text{mV}_{RMS})}$ (dB)

8224-04.TBL

ELECTRICAL CHARACTERISTICS (continued)

($T_{amb} = 25^{\circ}\text{C}$, $V_{CC} = 9\text{V}$, IF input = 10mV_{RMS} sync level at B/G, Peak-white level at L, Video modulation DSB, $D = 90\%$ at B/G, $D = 100\%$ at L, $f_{\text{PC}} = 38.9\text{MHz}$, $f_{\text{SC}} = 33.4\text{MHz}$, Video BW = 5MHz , Sound carrier input : 5.5MHz , 10mV_{RMS} , $f_{\text{M}} = 1\text{kHz}$, Audio BW = 20kHz , $\Delta f = \pm 50\text{kHz}$, Volume attenuation = 0dB , unless otherwise specified)

Symbol	Parameter	Test Conditions	Min.	Typ.	Max.	Unit
--------	-----------	-----------------	------	------	------	------

VIDEO SWITCH

$V_{\text{DC}12}$	DC Input Level	No signal	1.6	1.9	2.2	V
$V_{\text{S}12}$	Top Sync. Clamp Level			1.8		V
V_{11}	DC Output Level	No signal	1.4	1.7	2	V
$V_{\text{S}11}$	Top Sync. Clamp Level			1.5		V
	Crosstalk			55		dB
GEX	Gain from Ext. Input to Output		5.5	6	6.5	dB
	Output Swing		4			V
I_{12}	Input Current	$V_{12} = V_{\text{DC}12} = 1.5\text{V}$		1	5	μA
VBW	Bandwidth	$V_{\text{IN}} = 1\text{V}_{\text{PP}}$		15		MHz
G_{IN}	Gain from Int. Input to Output		-0.5	0	+0.5	dB

MUTE (Pin 9 or Pin 13)

V_9	Threshold Voltage			2.1		V
V_9	DC Level when Mute Disabled	High impedance controlling circuit		2.8		V
V_{13}	Threshold			0.3		V

CONTROL INPUT

	Negative Modulation	Video : External - Audio : External Video : Internal - Audio : Internal	7.2		1.8	V V
	Positive Modulation	Video : External - Audio : External Video : Internal - Audio : External	4.9 2.6		6.4 4.1	V V
	Threshold 3	Level linked to V_{CC}	6.4	6.8	7.2	V
	Threshold 2	Level linked to V_{CC}	4.1	4.5	4.9	V
	Threshold 1	Level linked to V_{CC}	1.8	2.2	2.6	V

8224-05.TBL

INPUT/OUTPUT PIN CONFIGURATION

Figure 1 : PIF PLL Filter

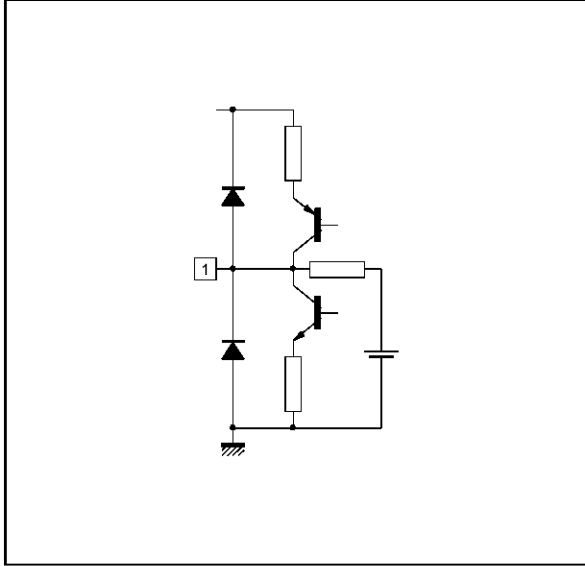

8224-03.EPS

Figure 2 : AFC Output

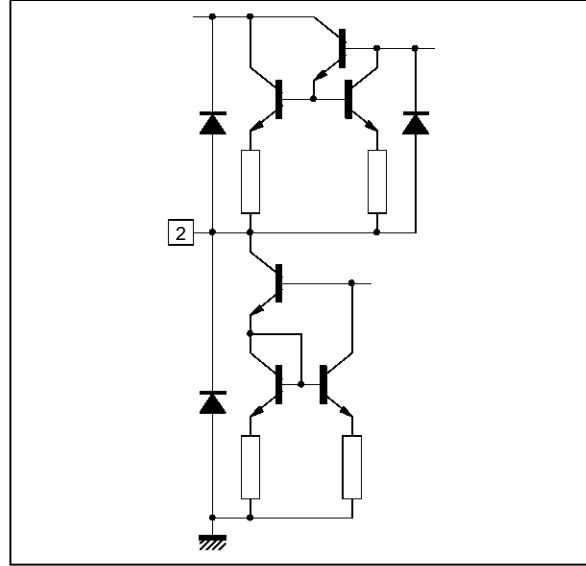

8224-04.EPS

Figure 3 : CVBS Output

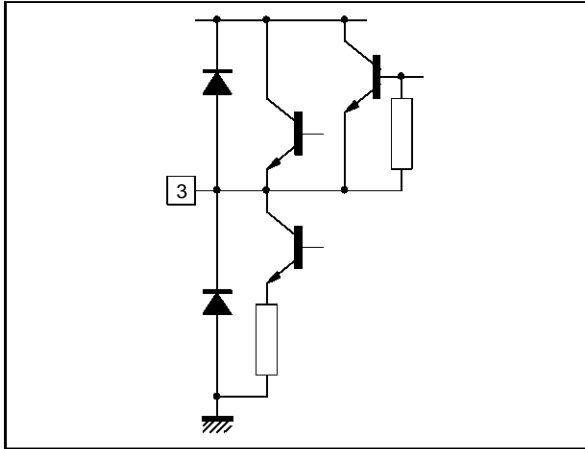

8224-05.EPS

Figure 4 : Switching Input Standard + INT/EXT

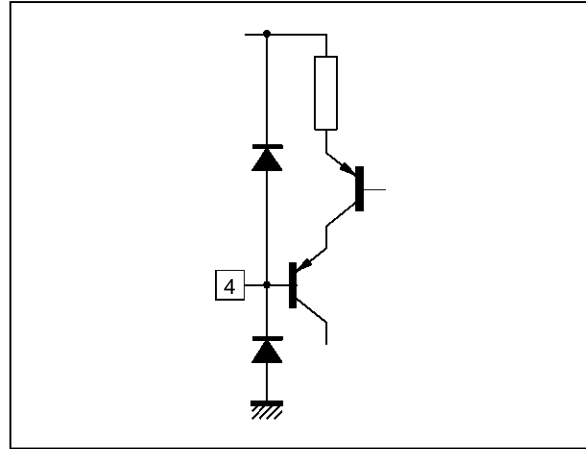

8224-06.EPS

Figure 5 : IFLC

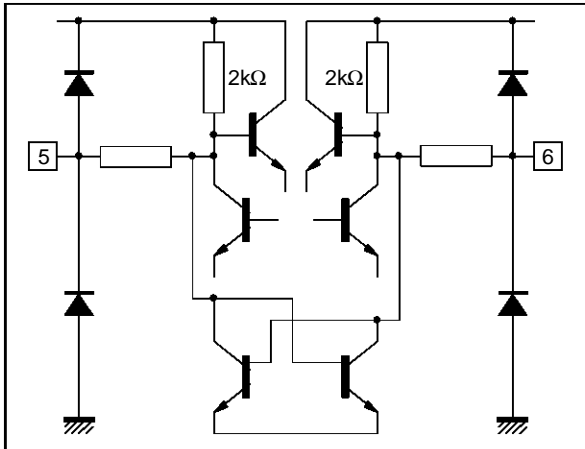

8224-07.EPS

Figure 6 : Audio High Pass Filter

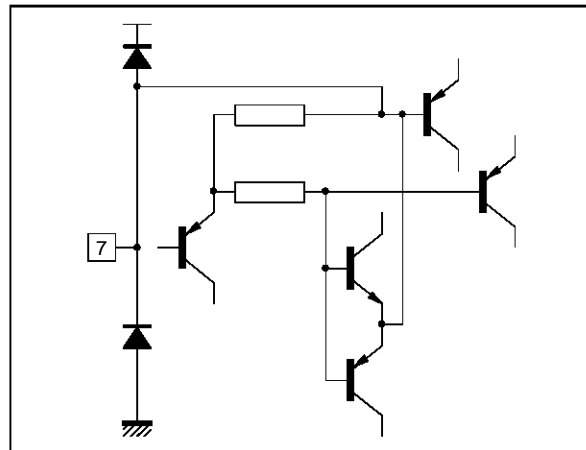

8224-08.EPS

INPUT/OUTPUT PIN CONFIGURATION (continued)

Figure 7 : 2CD IF Sound Input (Pin 8)
2CD IF Decoupling + Mute (Pin 9)

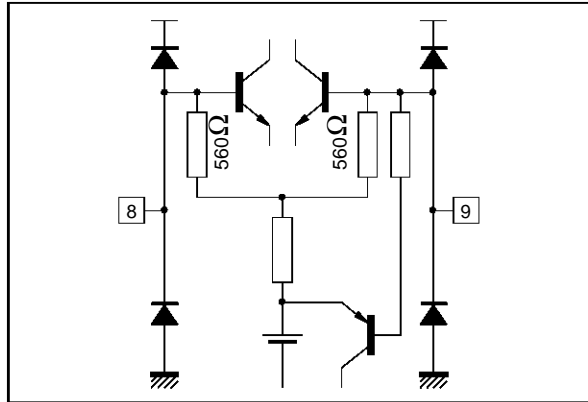

8224-09.EPS

Figure 8 : Internal Video Input

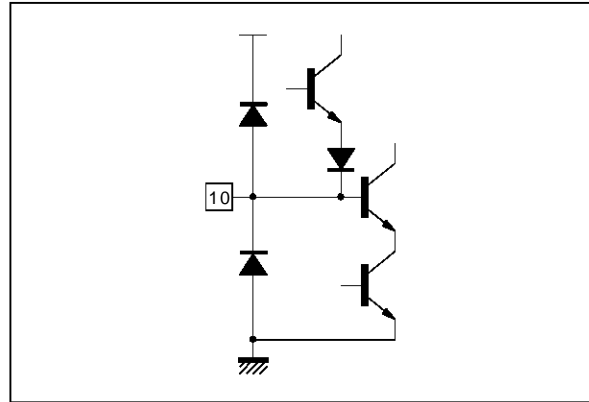

8224-10.EPS

Figure 9 : Video Switch Output

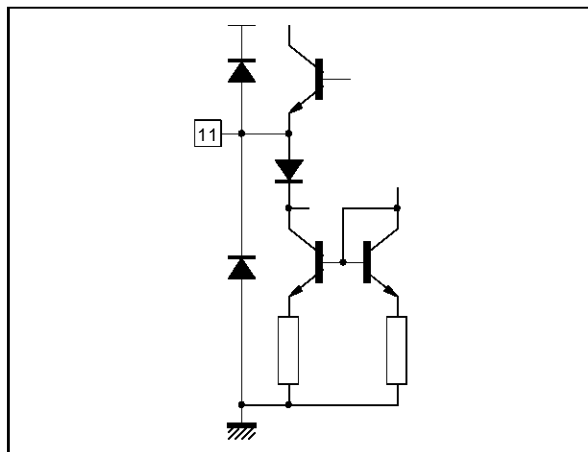

8224-11.EPS

Figure 10 : External Video Input

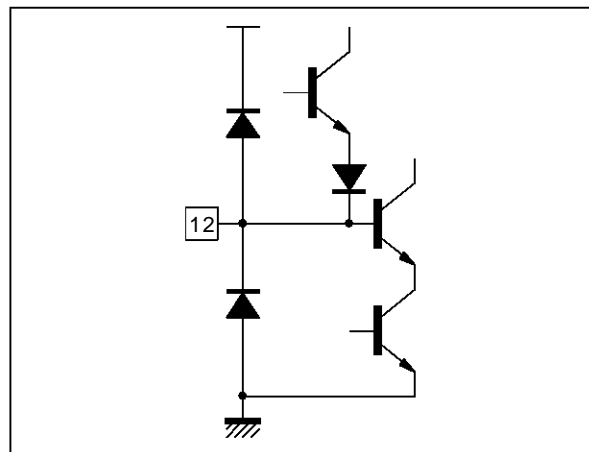

8224-12.EPS

Figure 11 : Volume Control + Mute

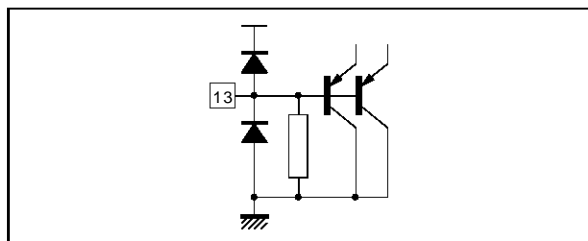

8224-13.EPS

Figure 12 : Audio Switch Output

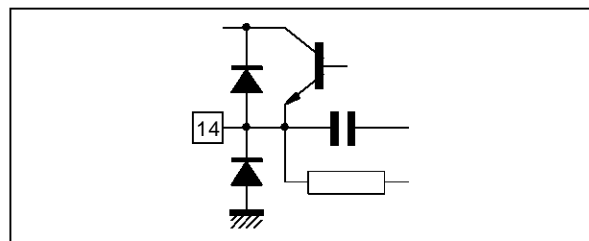

8224-14.EPS

Figure 13 : FM Demodulated Audio Output

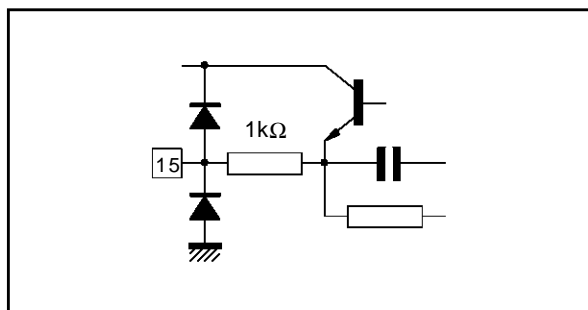

8224-15.EPS

Figure 14 : External Audio Input

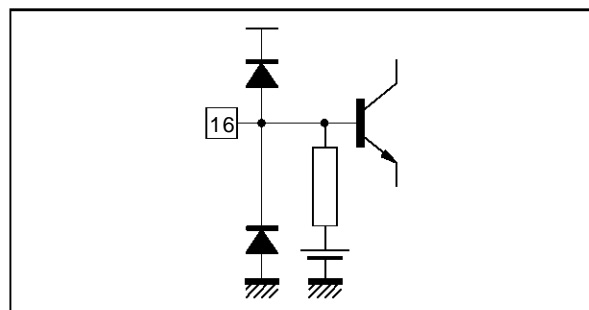

8224-16.EPS

INPUT/OUTPUT PIN CONFIGURATION (continued)

Figure 15 : Vcc

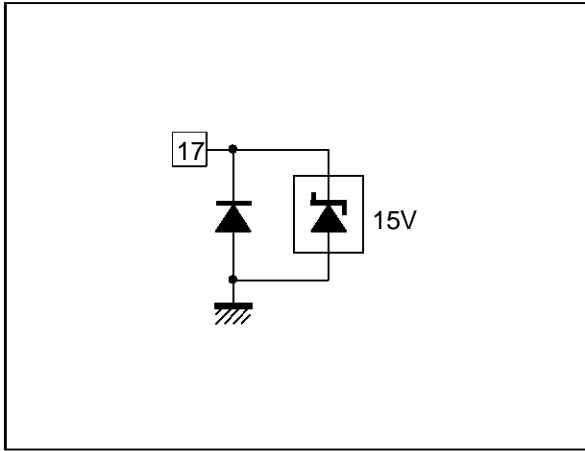

8224-17.EPS

Figure 16 : IF Input

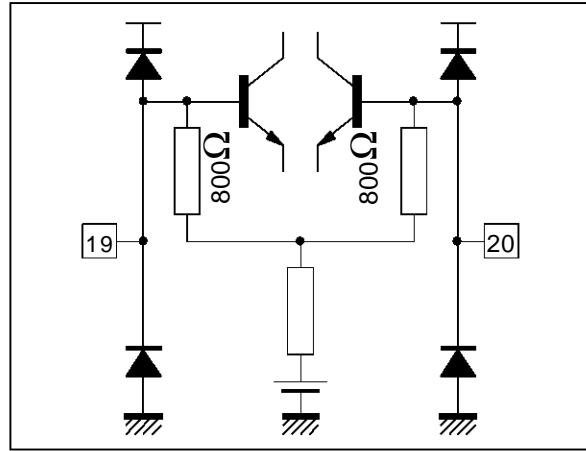

8224-18.EPS

Figure 17 : AGC Capacitor

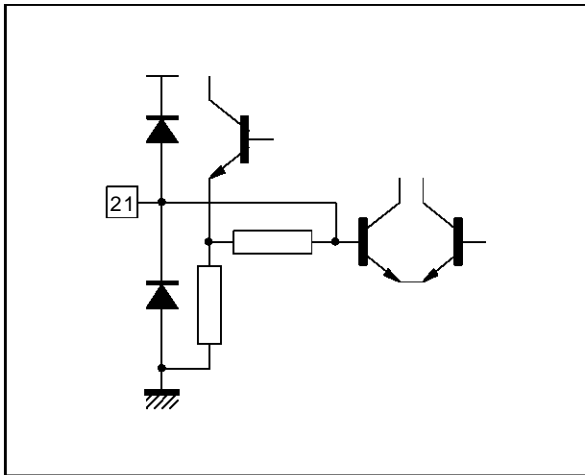

8224-19.EPS

Figure 18 : AGC Capacitor

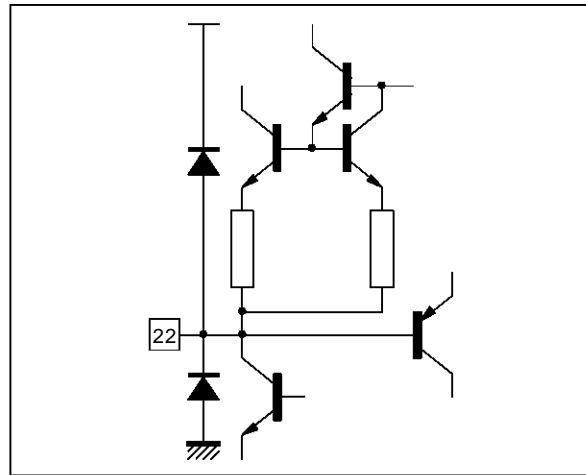

8224-20.EPS

Figure 19 : Tuner AGC Output

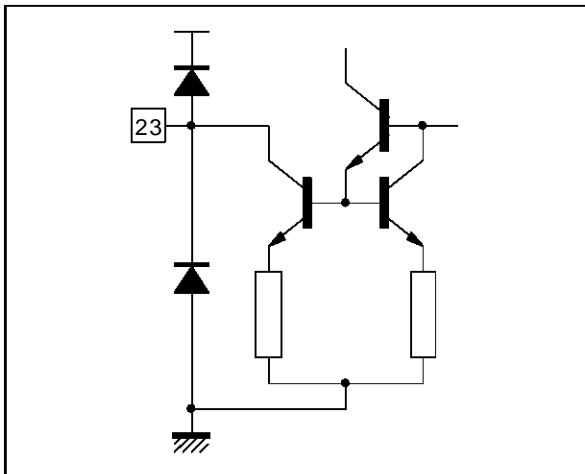

8224-21.EPS

Figure 20 : Tuner AGC Starting Point Adjustment

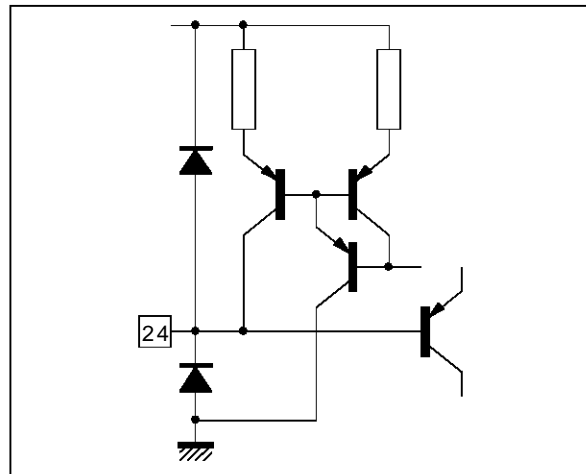

8224-22.EPS

APPLICATION DIAGRAM
STV8224

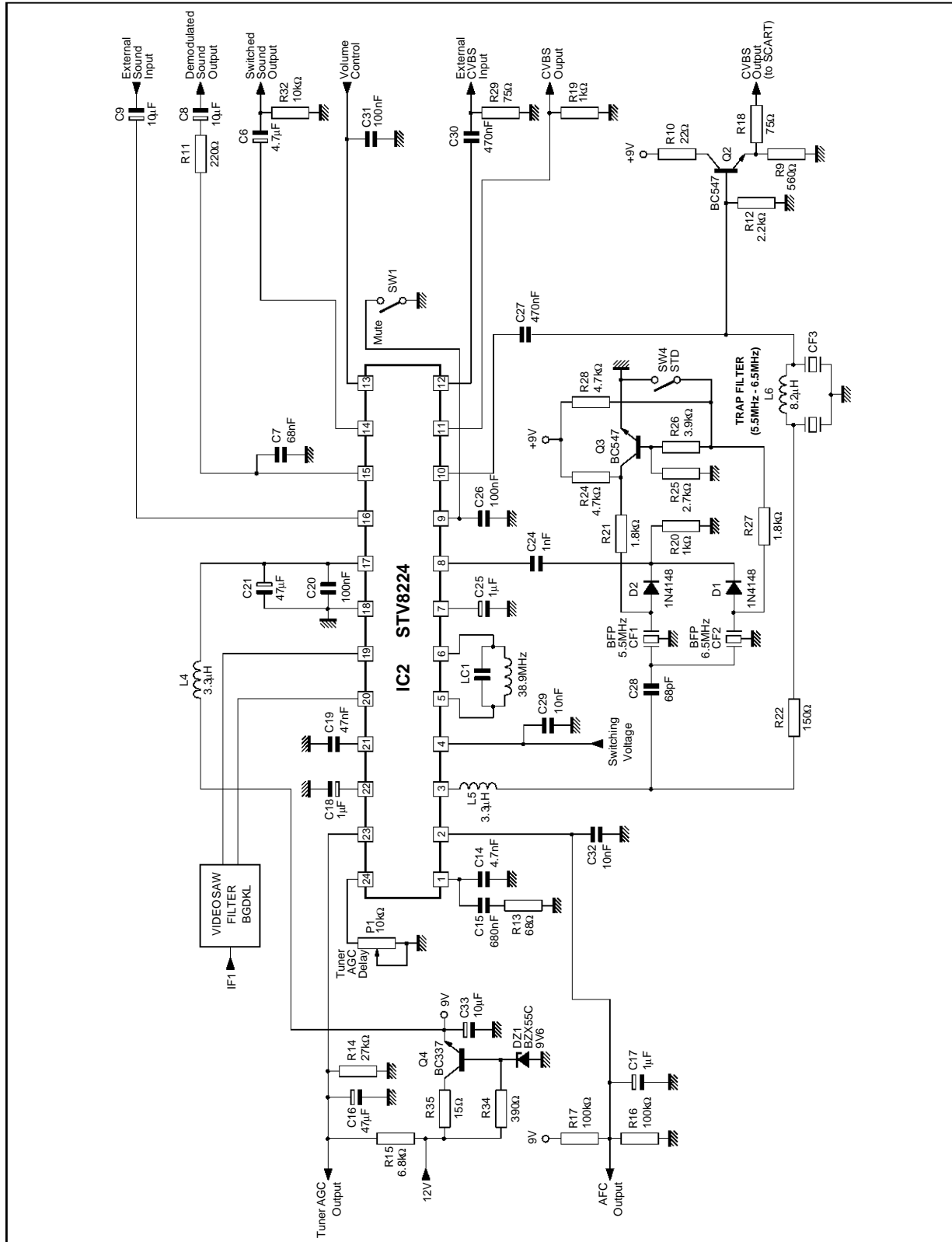

8224-23.EPS

APPLICATION DIAGRAM
STV8224 - STV8225

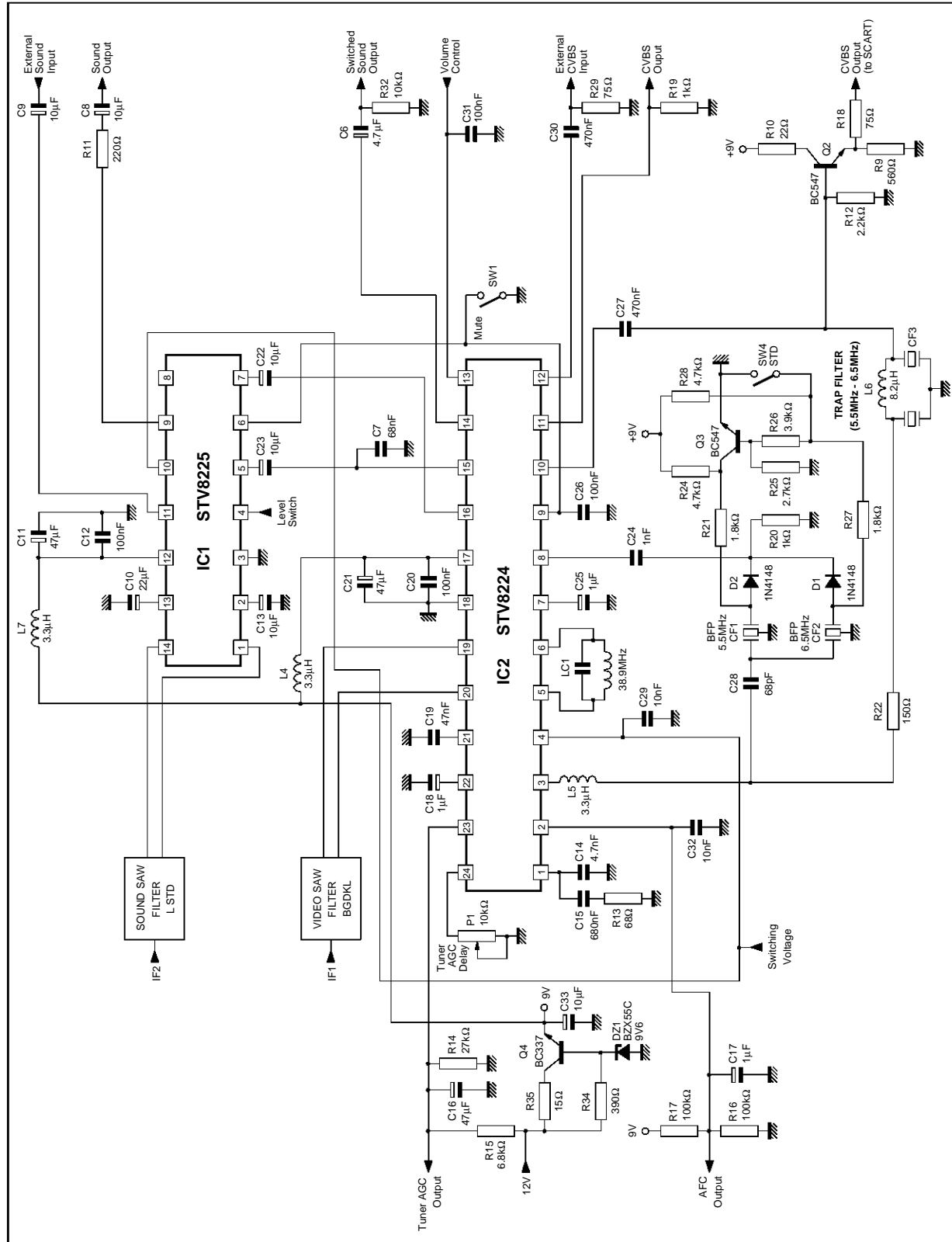

8224-24.EPS

PACKAGE MECHANICAL DATA
24 PINS - PLASTIC SHRINK DIP

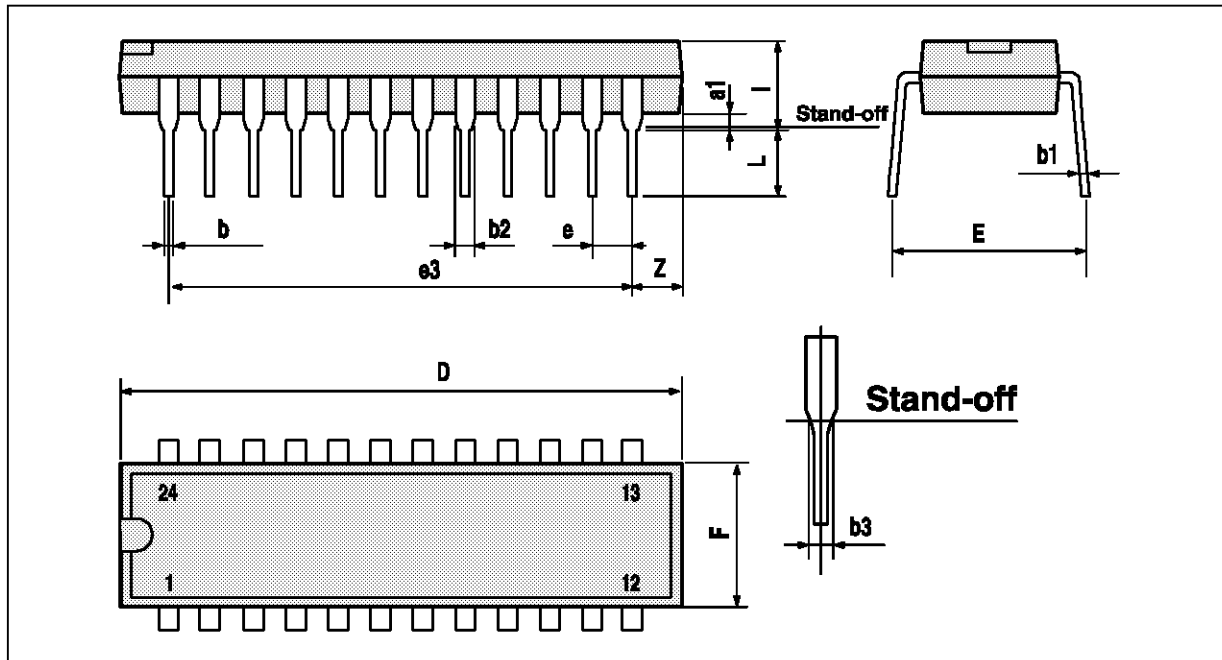

PMSDIP24.WMF

Dimensions	Millimeters			Inches		
	Min.	Typ.	Max.	Min.	Typ.	Max.
A		3.3			0.130	
a1	0.51			0.020		
b	0.35		0.59	0.014		0.023
b1	0.2		0.36	0.008		0.014
b2	0.75		1.42	0.030		0.056
b3	0.75			0.030		
D			23.11			0.910
E	7.95		9.73	0.313		0.383
e		1.778			0.070	
e3		19.558			0.770	
e4		7.62			0.300	
F			6.86			0.270
i			5.08			0.200
L	2.54			0.100		

SDIP24.TBL

Information furnished is believed to be accurate and reliable. However, SGS-THOMSON Microelectronics assumes no responsibility for the consequences of use of such information nor for any infringement of patents or other rights of third parties which may result from its use. No licence is granted by implication or otherwise under any patent or patent rights of SGS-THOMSON Microelectronics. Specifications mentioned in this publication are subject to change without notice. This publication supersedes and replaces all information previously supplied. SGS-THOMSON Microelectronics products are not authorized for use as critical components in life support devices or systems without express written approval of SGS-THOMSON Microelectronics.

© 1994 SGS-THOMSON Microelectronics - All Rights Reserved

Purchase of I²C Components of SGS-THOMSON Microelectronics, conveys a license under the Philips I²C Patent. Rights to use these components in a I²C system, is granted provided that the system conforms to the I²C Standard Specifications as defined by Philips.

SGS-THOMSON Microelectronics GROUP OF COMPANIES

Australia - Brazil - China - France - Germany - Hong Kong - Italy - Japan - Korea - Malaysia - Malta - Morocco
The Netherlands - Singapore - Spain - Sweden - Switzerland - Taiwan - Thailand - United Kingdom - U.S.A.