

HORIZONTAL AND VERTICAL DEFLECTION MONITOR

- DIRECT FRAME YOKE DRIVE $\pm 1.5A$ DRIVING CURRENT
- LINE DARLINGTON DRIVING CAPABILITY
- BUILT-IN FRAME SEPARATOR WITHOUT EXTERNAL COMPONENTS
- INTEGRATED FLYBACK GENERATOR
- FRAME OUTPUT PROTECTION AGAINST SHORT CIRCUITS
- VERY FEW EXTERNAL COMPONENTS
- HIGH DISSIPATION POWER PACKAGE
- SEPARATE POWER GROUND
- HORIZONTAL OSCILLATOR FREQUENCY RANGE FROM 15kHz TO 100kHz
- VERTICAL OSCILLATOR FREQUENCY RANGE FROM 30Hz TO 120Hz

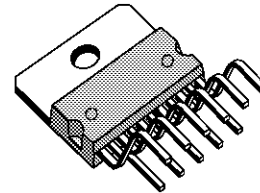

MULTIWATT 15
(Plastic Package)

ORDER CODE : TDA2117

DESCRIPTION

The TEA2117 is an horizontal and vertical deflection circuit. It is particularly intended for display video units. The TEA2117, with separate power ground, is particularly well-suited for high current applications.

PIN CONNECTIONS

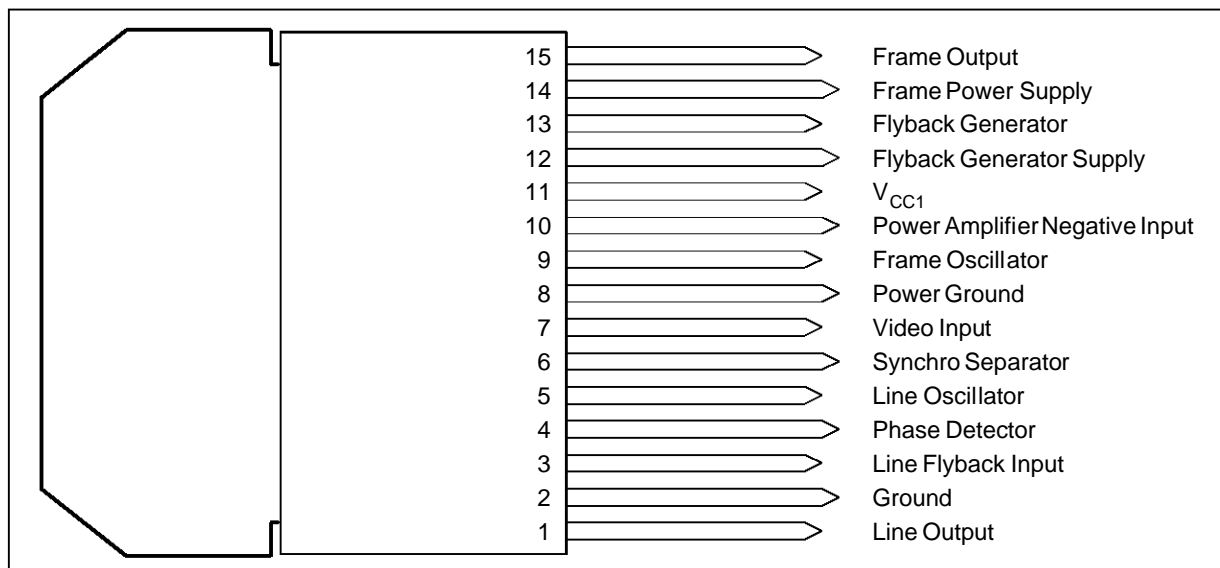

2117-01.EPS

BLOCK DIAGRAM

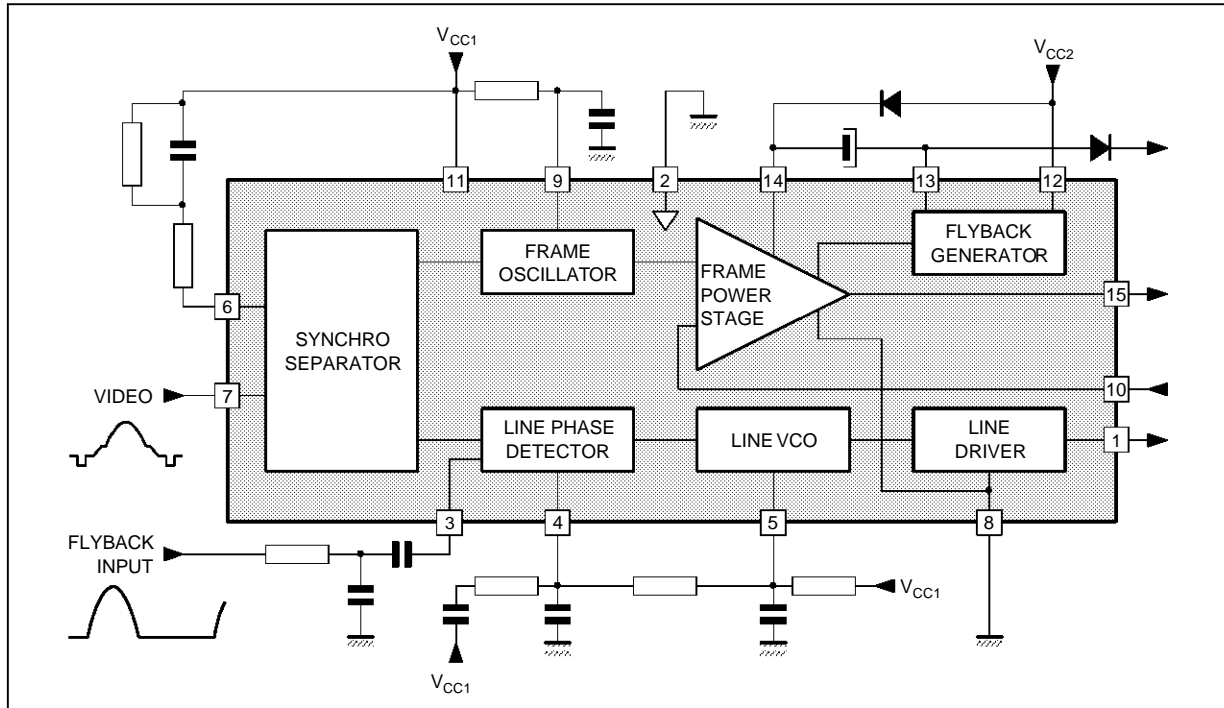

2117-02.EPS

ABSOLUTE MAXIMUM RATINGS

Symbol	Parameter	Value	Unit
V_{CC1}	Supply Voltage	20	V
V_{12}	Flyback Generator Supply Voltage	30	V
V_{14}	Frame Power Supply Voltage	60	V
I_{15}	Frame Output Current	± 1.5	A
V_1	Line Output Voltage (external)	60	V
I_{P1}	Line Output Peak Current	0.8	A
I_{C1}	Line Output Continuous Current	0.4	A
T_{stg}	Storage Temperature	- 40, + 150	$^{\circ}C$
T_j	Max Operating Junction Temperature	150	$^{\circ}C$

2117-01.TBL

THERMAL DATA

Symbol	Parameter	Value	Unit
$R_{th(j-c)}$	Max Junction-case Thermal Resistance	3	$^{\circ}C/W$
$R_{th(j-a)}$	Typical Junction-ambient Thermal Resis.	40	$^{\circ}C/W$
T_j	Max Recommended Junction Temperature	120	$^{\circ}C$

2117-02.TBL

ELECTRICAL CHARACTERISTICS ($T_{amb} = 25^{\circ}C$, $V_{CC1} = 10V$)

Symbol	Parameter	Min.	Typ.	Max.	Unit
SUPPLY (Pin 11)					
I_{CC1}	Supply Current		15		mA
V_{CC1}	Supply Voltage	8		20	V
VIDEO INPUT (Pin 7)					
V_7	Input Threshold Voltage ($I_7 = -1\mu A$)		4		V
	Video Input Signal (see application diagram)	0.4		4	V_{pp}

2117-03.TBL

ELECTRICAL CHARACTERISTICS (continued)T_{amb} = 25°C, V_{CC1} = 10V

Symbol	Parameter	Min.	Typ.	Max.	Unit
LINE FLYBACK INPUT (Pin 3)					
V ₃	Bias Voltage		2.7		V
Z ₃	Input Impedance	4.5	6	8	kΩ

PHASE COMPARATOR (Pin 4)

I ₄	Output Current During Synchro Pulse		± 600		μA
I _{4R}	Current Ratio (positive/negative)	0.9	1.0	1.1	
LI4	Leakage Current	- 1		+ 1	μA
	Control Range Voltage	2.5		7	V
	Control Sensibility (see application diagram)		750		Hz/μs
	Pull in Range (see application diagram)		± 800		Hz

LINE OSCILLATOR (Pin 5)

LT5	Low Threshold Voltage		3.2		V
HT5	High Threshold Voltage		6.6		V
BI5	Bias Current		50		nA
DR5	Discharge Impedance		800		Ω
FLP1	Free Running Line Period (R = 12kΩ tied to V _{CC1} , C = 6.8nF tied to Ground)	61.5	64	66.5	μs
FLP2	Free Running Line Period (R = 12.3kΩ, C = 2.2nF)		27		μs
OT5	Oscillator Threshold for Line Output Pulse Triggering		5		V
$\frac{\Delta T}{\Delta V}$	Supply Voltage Influence on Free-running Period		0.051		μs/V

T_{amb} = 25°C, V_{CC1} = 10V, V₁₄ = 30V

Symbol	Parameter	Min.	Typ.	Max.	Unit
LINE OUTPUT (Pin 1)					
LV1	Saturation Voltage to Ground (I ₁ = 200mA)		1.1	1.5	V
CPW	Output Pulse Width (line period = 64μs)	20	22	24	μs

FRAME OSCILLATOR (Pin 9)

LT9	Low Threshold Voltage	1.8	2	2.3	V
HT9	High Threshold Voltage	2.6	3.1	3.6	V
BI9	Bias Current		100		nA
DR9	Discharge Impedance		500		Ω
FFP1	Free Running Frame Period (R = 845kΩ tied to V _{CC1} , C = 180nF tied to Ground)	21.4	22.5	25	ms
FFP2	Free Running Frame Period (R = 425kΩ, C = 220nF)		14.3		ms
MFP	Minimum Frame Period (I ₇ = - 100μA) with the Same RC	14.6	17	19	ms
FG	Frame Sawtooth Gain between Pin 9 and Non-inverting Input of the Frame Amplifier (internal)		- 0.4		

FRAME POWER SUPPLY (Pin 14)

V ₁₄	Operating Voltage (with flyback generator)	10		58	V
I ₁₄	Supply Current (V ₁₄ = 30V)		16	25	mA

FLYBACK GENERATOR SUPPLY (Pin 12)

V ₁₂	Operating Voltage	10		30	V
-----------------	-------------------	----	--	----	---

FRAME OUTPUT

LV15A LV15B	Saturation Voltage to Ground I ₁₅ = 0.1A I ₁₅ = 1A		60 0.4		mV V
----------------	--	--	-----------	--	---------

2117-04.TBL

ELECTRICAL CHARACTERISTICS ($T_{amb} = 25^{\circ}\text{C}$, $V_{CC1} = 10\text{V}$, $V_{14} = 30\text{V}$) (continued)

Symbol	Parameter	Min.	Typ.	Max.	Unit
FRAME OUTPUT (continued)					
HV15A HV15B	Saturation Voltage to V_{CC2} $I_{15} = -0.1\text{A}$ $I_{15} = -1\text{A}$		1.3 1.7	2.4	V V
FV15A FV15B	Saturation Voltage to V_{CC2} in Flyback Mode ($V_{15} > V_{14}$) $I_{15} = 0.1\text{A}$ $I_{15} = 1\text{A}$		1.7 2.6	4	V V
FLYBACK GENERATOR (Pins 12 and 13)					
F2DA F2DB	Flyback Transistor on (output = high state) $V_{13/12}$ with $I_{13 \rightarrow 12} = 0.1\text{A}$ $I_{13 \rightarrow 12} = 1\text{A}$		1.6 3	4	V V
FSVA FSVB	Flyback Transistor on (output = high state) $V_{12/13}$ with $I_{12 \rightarrow 13} = 0.1\text{A}$ $I_{12 \rightarrow 13} = 1\text{A}$		0.9 2	4	V V
FCI	Flyback Transistor off (output = $V_{14} - 8\text{V}$) $V_{12} = V_{14} = 30\text{V}$ Leakage Current Pin 12			100	μA

2117-05.TBL

GENERAL DESCRIPTION

The TEA2117 performs all of the video and power functions required to provide signals for the direct drive of a line darlington and the frame yoke.

It contains:

- A synchronizing separator with the slice level of synchro separation determined by the external components.
- An integrated frame synchronizing separator without external components.
- A saw tooth generator for the frame with synchronization allowed during the last fourth of the free run period.
- A power amplifier for direct drive of the frame yoke with overload, short circuit and thermal protections.
- A line phase detector and a voltage control oscillator.
- An open collector output for the direct drive of a line darlington.
- Separate power ground (Pin 8)

SYNCHRONIZATION SEPARATOR CIRCUIT

(Figure 1)

The sync-tip DC level on pin 7 is clamped to 3.8V. The slice level of sync-separation present on capacitor C1 depends on the value of resistor R1 and R2. When the video signal on pin 7 decreases under the capacitor voltage the transistors Q1 and Q2 provide current for the other parts of the circuit.

FRAME SEPARATOR (Figure 2)

The sync-pulse allows the discharge of the capacitor by a $2 \times I$ current. A line sync-pulse is not able to discharge the capacitor under $V_z/2$. A frame sync pulse permits the complete discharge of the capacitor, so during the frame sync-pulse Q3 and Q4 provide current for the other parts of the circuit.

LINE OSCILLATOR (Figure 3)

The oscillator thresholds are internally fixed by resistors. The discharge of the capacitor depends on the internal resistor R4. The voltage control is applied on resistor R5.

PHASE COMPARATOR (Figure 4)

The sync-pulse drives the current in the comparator. The line flyback integrated by the external network gives on pin 3 a saw tooth, the DC offset of this saw tooth is fixed by VC. The comparator output provides a positive current for the part of the signal on pin 3 superior to VC and a negative current for the other part. When the line flyback and the video signal are synchronized, the output of the comparator is an alternately negative and positive current. The frame sync-pulse inhibits the comparator to prevent frequency drift of the line oscillator on the frame beginning. (see Figure 5)

LINE OUTPUT (Pin1)

It is an open collector output which is able to drive pulse current of 500mA for a rapid discharging of the darlington base. The output pulse time is 22 μs for a 64 μs period.

FRAME OSCILLATOR (Figure 6)

The oscillator thresholds are internally fixed by resistors. The oscillator is synchronized during the last fourth of the free run period. The input current during the charge of the capacitor is less than 100nA.

FRAME OUTPUT AMPLIFIER

This amplifier is able to drive directly the frame yoke. Its output is short circuit and overload protected ; it contains also a thermal protection. Its positive input is directly connected to the invert of the frame saw tooth.

Figure 1

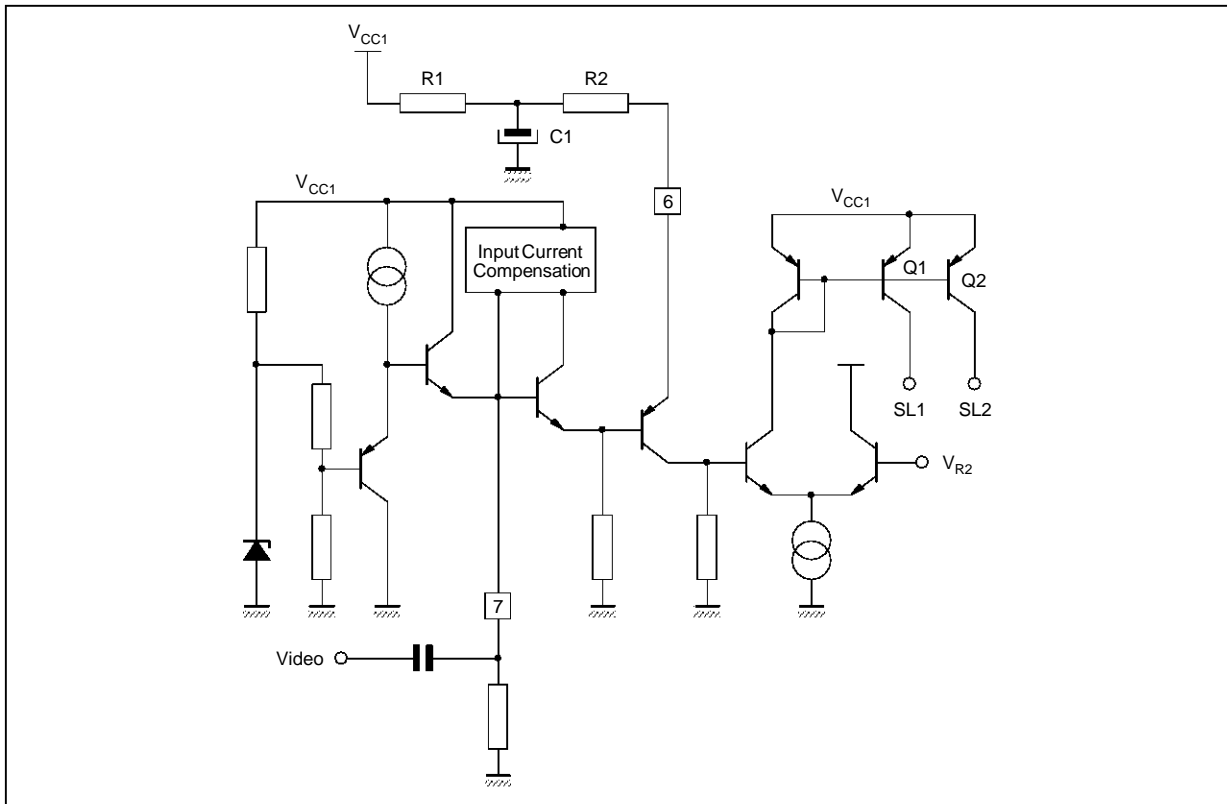

2117-03.EPS

Figure 2

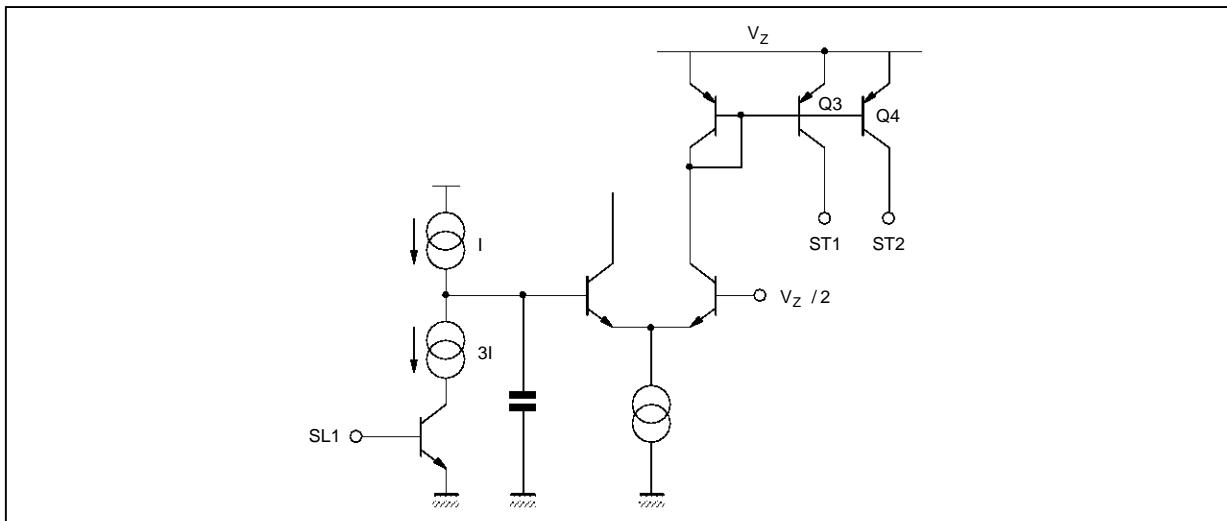

2117-04.EPS

Figure 3

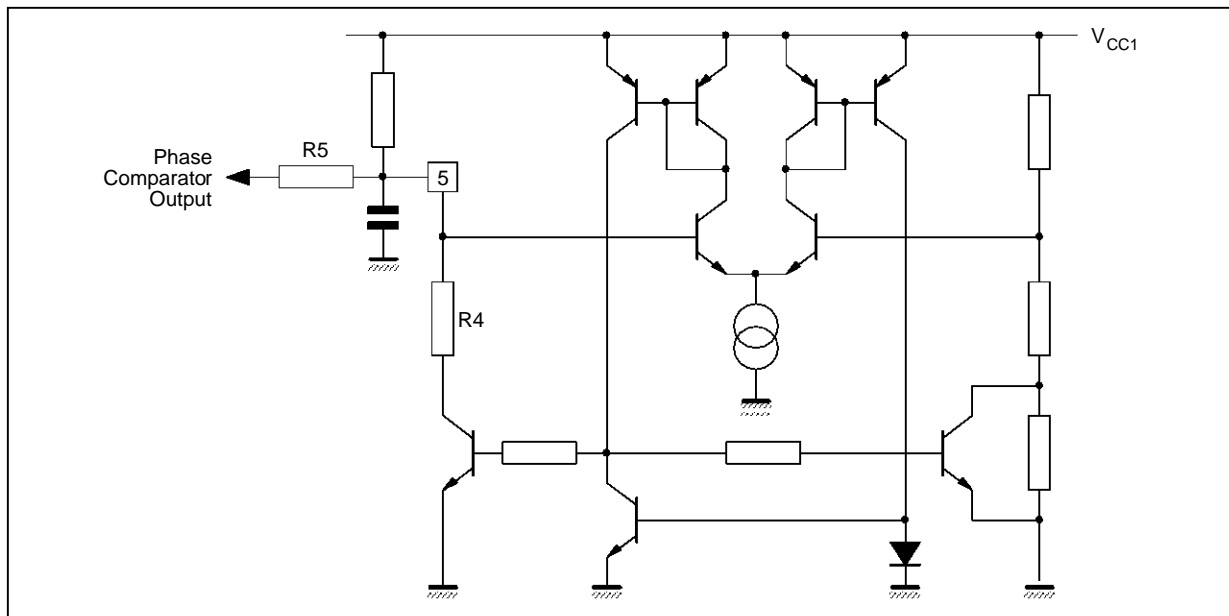

2117-06.EPS

Figure 4

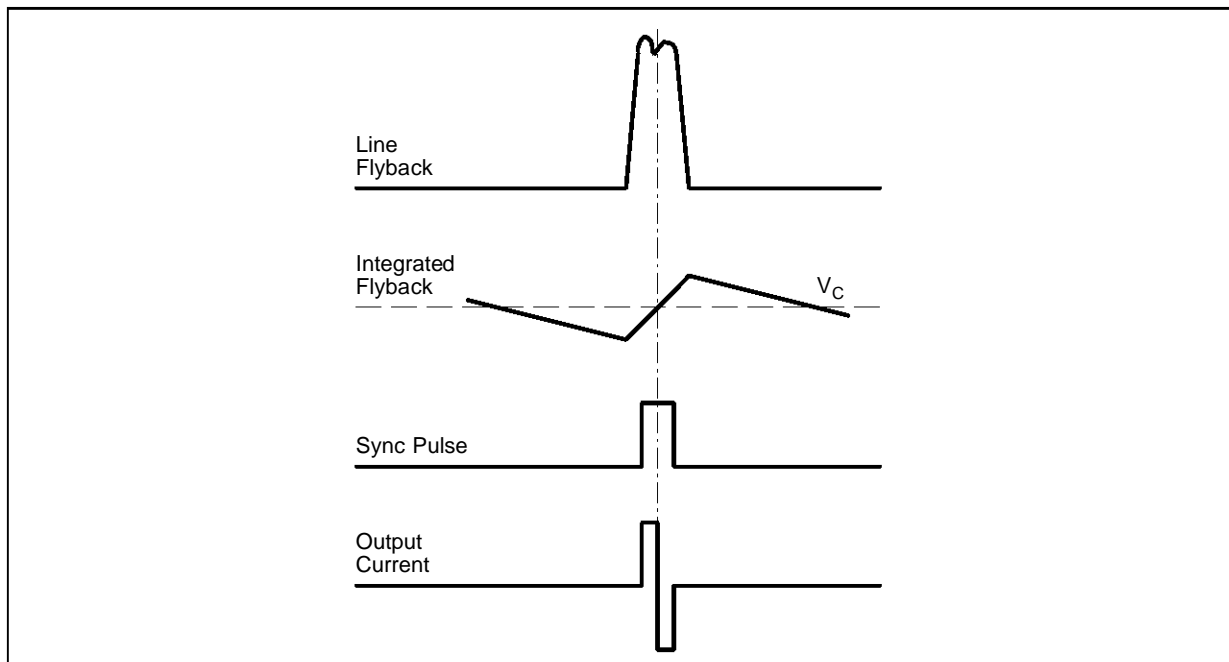

2117-06.EPS

Figure 5

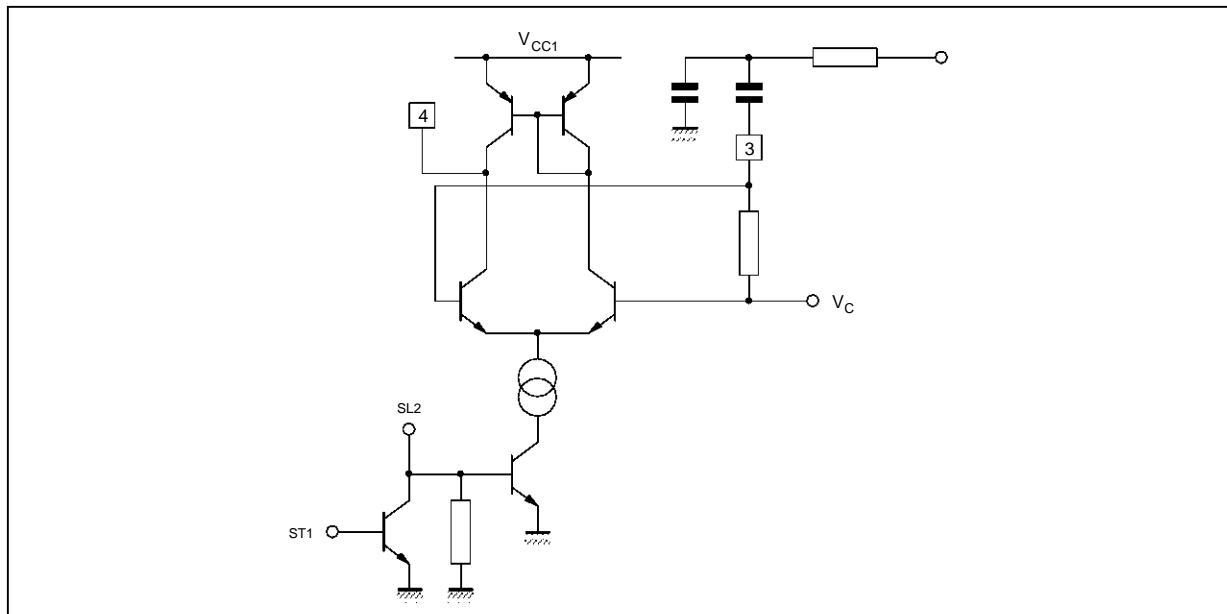

2117-07.EPS

Figure 6

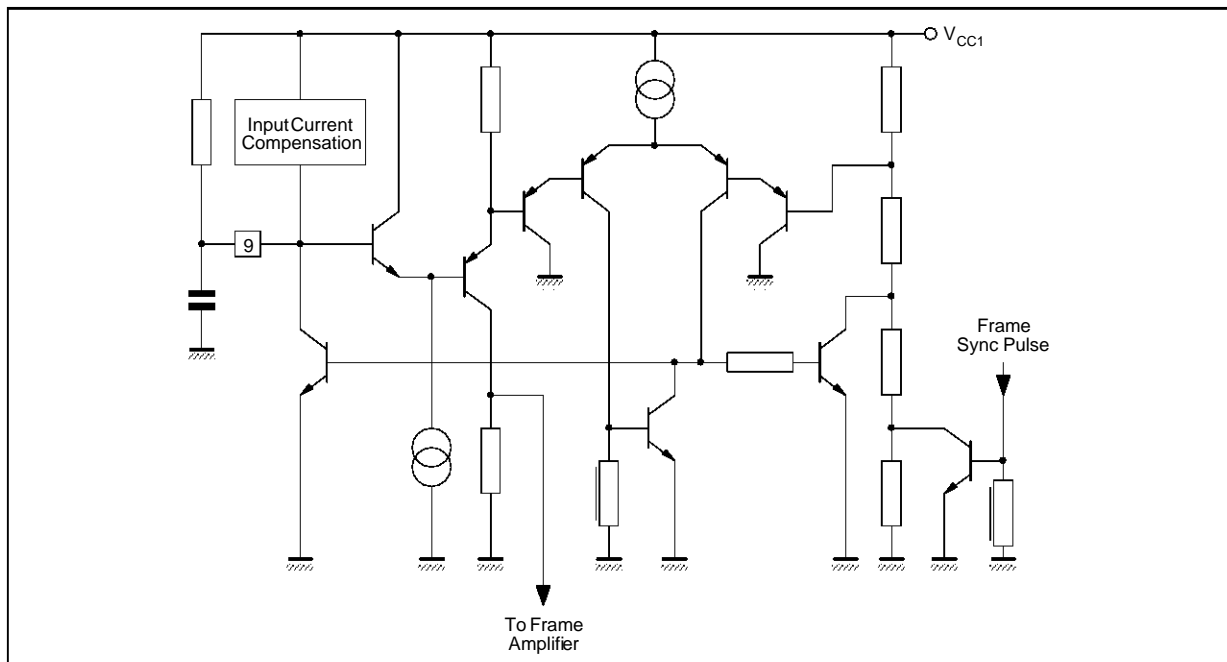

2117-08.EPS

TEA2117

APPLICATION DIAGRAM (without internal flyback generator)
 TYPICAL BLACK-WHITE MONITOR APPLICATION FOR 14" - 90° SCREEN
 (with yoke L = 5.8mH, R = 2.7Ω, I_{PP} = 2A), f_H = 31.kHz, f_V = 60/70Hz

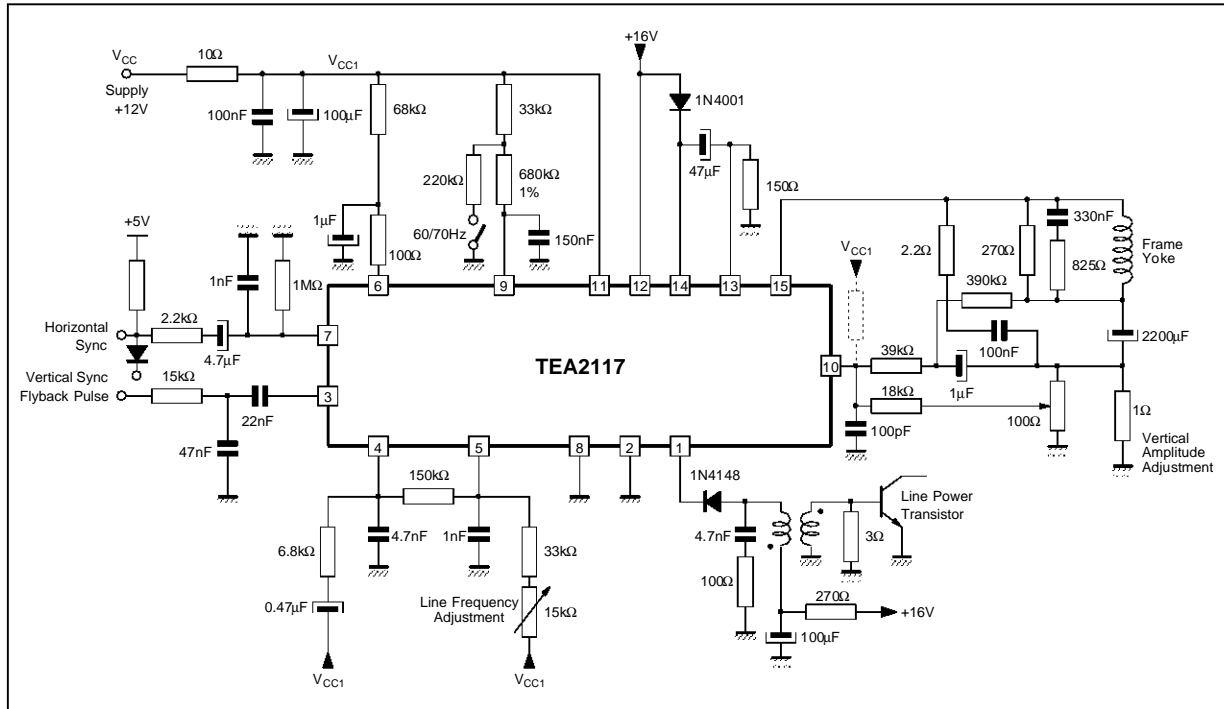

2117-08.EPS

PACKAGE MECHANICAL DATA : 15 PINS - PLASTIC MULTIWATT

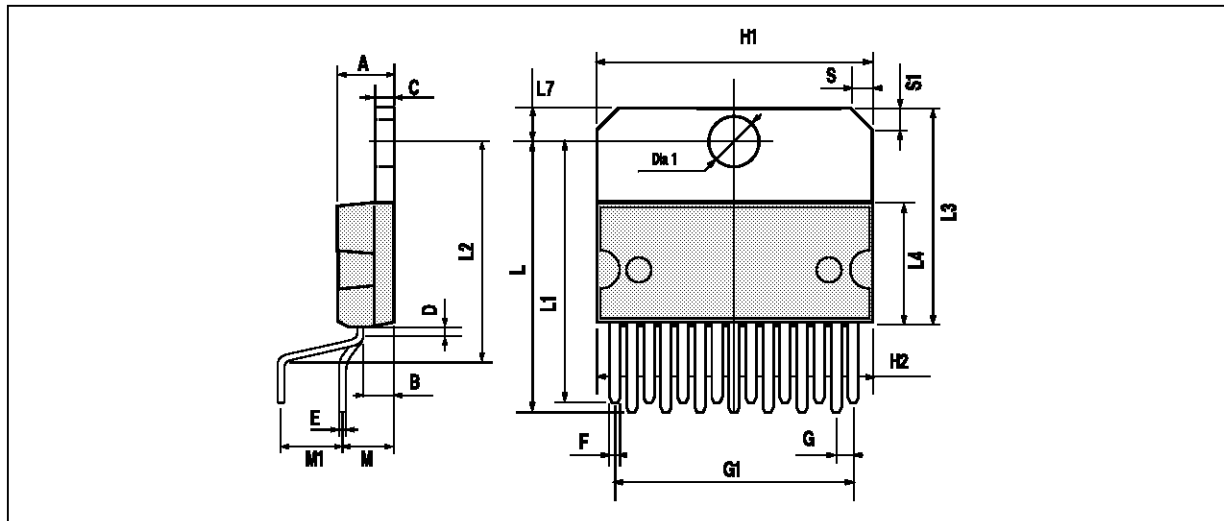

PMUL15V/EPS

Dimensions	Millimeters			Inches		
	Min.	Typ.	Max.	Min.	Typ.	Max.
A			5			0.197
B			2.65			0.104
C			1.6			0.063
D		1			0.039	
E	0.49		0.55	0.019		0.022
F	0.66		0.75	0.026		0.030
G	1.14	1.27	1.4	0.045	0.050	0.055
G1	17.57	17.78	17.91	0.692	0.700	0.705
H1	19.6			0.772		
H2			20.2			0.795
L	22.1		22.6	0.870		0.890
L1	22		22.5	0.866		0.886
L2	17.65		18.1	0.695		0.713
L3	17.25	17.5	17.75	0.679	0.689	0.699
L4	10.3	10.7	10.9	0.406	0.421	0.429
L7	2.65		2.9	0.104		0.114
M	4.2	4.3	4.6	0.165	0.169	0.181
M1	4.5	5.08	5.3	0.177	0.200	0.209
S	1.9		2.6	0.075		0.102
S1	1.9		2.6	0.075		0.102
Dia. 1	3.65		3.85	0.144		0.152

MUL15V.TBL

Information furnished is believed to be accurate and reliable. However, SGS-THOMSON Microelectronics assumes no responsibility for the consequences of use of such information nor for any infringement of patents or other rights of third parties which may result from its use. No licence is granted by implication or otherwise under any patent or patent rights of SGS-THOMSON Microelectronics. Specifications mentioned in this publication are subject to change without notice. This publication supersedes and replaces all information previously supplied. SGS-THOMSON Microelectronics products are not authorized for use as critical components in life support devices or systems without express written approval of SGS-THOMSON Microelectronics.

© 1994 SGS-THOMSON Microelectronics - All Rights Reserved

Purchase of I²C Components of SGS-THOMSON Microelectronics, conveys a license under the Philips I²C Patent. Rights to use these components in a I²C system, is granted provided that the system conforms to the I²C Standard Specifications as defined by Philips.

SGS-THOMSON Microelectronics GROUP OF COMPANIES

Australia - Brazil - China - France - Germany - Hong Kong - Italy - Japan - Korea - Malaysia - Malta - Morocco
The Netherlands - Singapore - Spain - Sweden - Switzerland - Taiwan - Thailand - United Kingdom - U.S.A.