

# DATA SHEET

## **TDA9812**

Multistandard VIF-PLL and  
FM-PLL/AM demodulator

Preliminary specification  
File under Integrated Circuits, IC02

1995 Mar 21

Philips Semiconductors



**PHILIPS**

## Multistandard VIF-PLL and FM-PLL/AM demodulator

## TDA9812

### FEATURES

- 5 V positive supply voltage
- Gain controlled wide band VIF-amplifier (AC-coupled)
- True synchronous demodulation with active carrier regeneration (very linear demodulation, good intermodulation figures, reduced harmonics, excellent pulse response)
- Gated phase detector for L/L accent standard
- VCO frequency switchable between L and L accent (alignment external) picture carrier frequency
- Separate video amplifier for sound trap buffering with high video bandwidth
- VIF AGC detector for gain control, operating as peak sync detector for B/G (optional external AGC) and peak white detector for L; signal controlled reaction time for L
- Tuner AGC with adjustable Take Over Point (TOP)
- AFC detector without extra reference circuit
- AC-coupled limiter amplifier for sound intercarrier signal
- Alignment-free FM-PLL demodulator with high linearity, switchable de-emphasis for FM
- AM-SIF AGC detector for gain controlled SIF amplifier
- AM demodulator without extra reference circuit
- Stabilizer circuit for ripple rejection and to achieve constant output signals.

### GENERAL DESCRIPTION

The TDA9812/T is an integrated circuit for multistandard vision IF signal processing and AM and FM sound demodulation in TV and VTR sets.

### ORDERING INFORMATION

TYPE NUMBER	PACKAGE		
	NAME	DESCRIPTION	VERSION
TDA9812	SDIP32	plastic shrink dual in-line package; 32 leads (400 mil)	SOT232-1
TDA9812T	SO28	plastic small outline package; 28 leads body width 7.5 mm	SOT136-1

# Multistandard VIF-PLL and FM-PLL/AM demodulator

TDA9812

## QUICK REFERENCE DATA

SYMBOL	PARAMETER	CONDITIONS	MIN.	TYP.	MAX.	UNIT
$V_P$	supply voltage		4.5	5	5.5	V
$I_P$	supply current		82	96	110	mA
$V_{i\text{ VIF(rms)}}$	vision IF input signal voltage sensitivity (RMS value)	-1 dB video at output	-	60	100	$\mu\text{V}$
$V_{o\text{ CVBS(p-p)}}$	CVBS output signal voltage (peak-to-peak value)		1.7	2.0	2.3	V
$B_{-3}$	-3 dB video bandwidth on pin CVBS	B/G and L standard; $C_L < 20\text{ pF}$ ; $R_L > 1\text{ k}\Omega$ ; AC load	7	8	-	MHz
S/N(W)	weighted signal-to-noise ratio for video		56	60	-	dB
$IM_{\alpha 1.1}$	intermodulation attenuation at 'blue'	$f = 1.1\text{ MHz}$	58	64	-	dB
$IM_{\alpha 3.3}$	intermodulation attenuation at 'blue'	$f = 3.3\text{ MHz}$	58	64	-	dB
$\alpha_{H(\text{sup})}$	suppression of harmonics in video signal		35	40	-	dB
$V_{i\text{ SIF(rms)}}$	sound IF input signal voltage sensitivity (RMS value)	-3 dB video at AF output	-	70	100	$\mu\text{V}$
$V_{o(\text{rms})}$	audio output signal voltage for FM (RMS value)	B/G standard; 54% modulation	-	0.5	-	V
	audio output signal voltage for AM (RMS value)	L standard; 54% modulation	-	0.5	-	V
THD	total harmonic distortion	54% modulation				
	FM		-	0.15	0.5	%
	AM		-	0.5	1.0	%
S/N (W)	weighted signal-to-noise ratio	54% modulation				
	FM		-	60	-	dB
	AM		47	53	-	dB

Multistandard VIF-PLL and FM-PLL/AM demodulator

TDA9812

BLOCK DIAGRAM

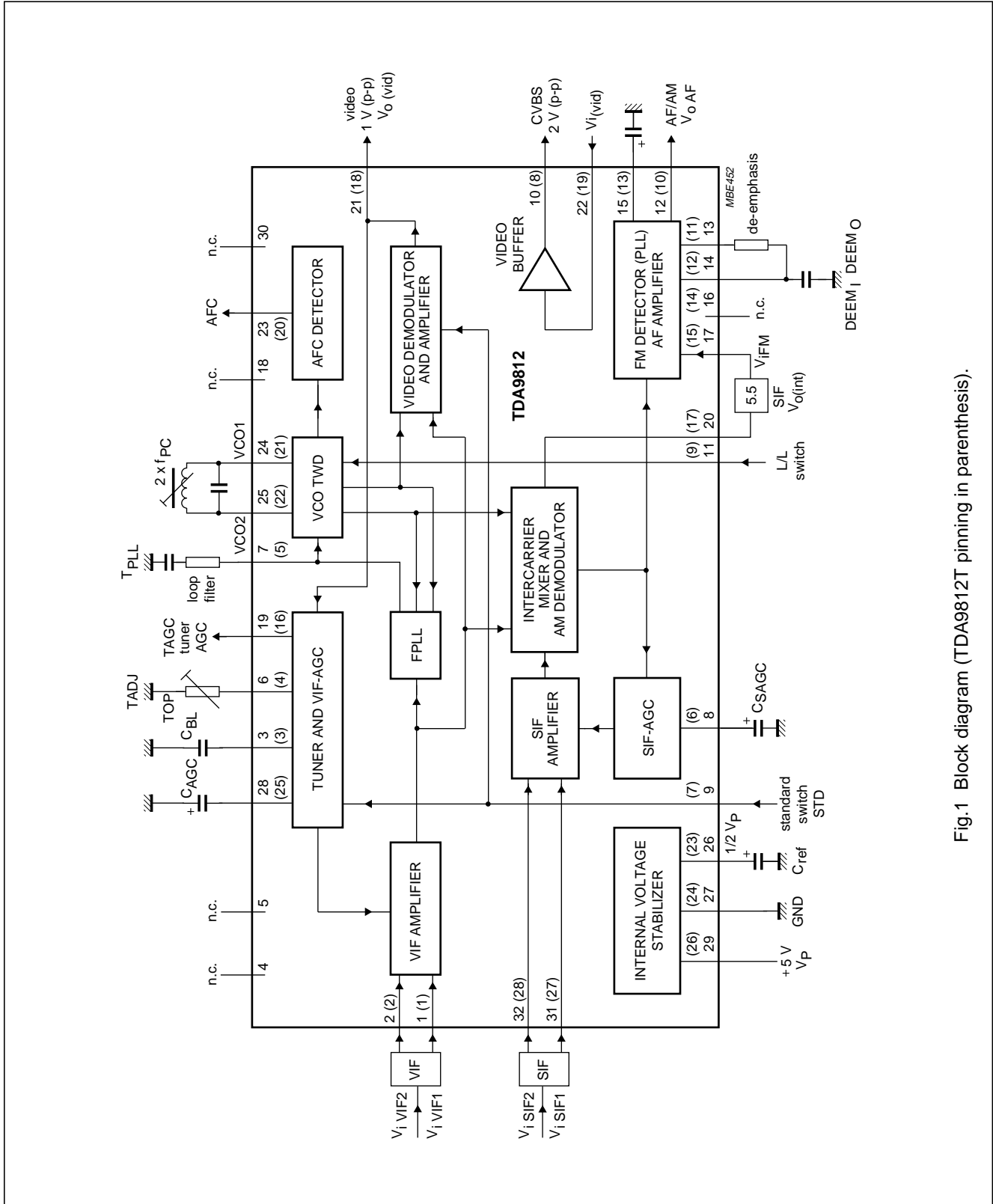

Fig.1 Block diagram (TDA9812T pinning in parenthesis).

# Multistandard VIF-PLL and FM-PLL/AM demodulator

TDA9812

## PINNING

SYMBOL	PIN SDIP32	PIN SO28	DESCRIPTION
$V_{i\ VIF1}$	1	1	VIF differential input signal voltage 1
$V_{i\ VIF2}$	2	2	VIF differential input signal voltage 2
$C_{BL}$	3	3	black level detector
n.c.	4	–	not connected
n.c.	5	–	not connected
TADJ	6	4	tuner AGC take-over adjust (TOP)
$T_{PLL}$	7	5	PLL loop filter
$C_{SAGC}$	8	6	SIF AGC capacitor
STD	9	7	standard switch
$V_{o\ CVBS}$	10	8	CVBS output signal voltage
LSWI	11	9	L/L accent switch
$V_{o\ AF}$	12	10	audio voltage frequency output
$DEEM_I$	13	11	de-emphasis input
$DEEM_O$	14	12	de-emphasis output
$C_{DEC}$	15	13	decoupling capacitor
n.c.	16	14	not connected
$V_{i\ FM}$	17	15	sound intercarrier input voltage
n.c.	18	–	not connected
TAGC	19	16	tuner AGC output
$V_{o(int)}$	20	17	sound intercarrier output voltage
$V_{o(vid)}$	21	18	composite video output voltage
$V_{i(vid)}$	22	19	video buffer input voltage
AFC	23	20	AFC output
VCO1	24	21	VCO1 reference circuit for $2f_{PC}$
VCO2	25	22	VCO2 reference circuit for $2f_{PC}$
$C_{ref}$	26	23	$\frac{1}{2}V_P$ reference capacitor
GND	27	24	ground
$C_{VAGC}$	28	25	VIF AGC capacitor
$V_P$	29	26	supply voltage
n.c.	30	–	not connected
$V_{i\ SIF1}$	31	27	SIF differential input signal voltage 1
$V_{i\ SIF2}$	32	28	SIF differential input signal voltage 2

Multistandard VIF-PLL and FM-PLL/AM demodulator

TDA9812

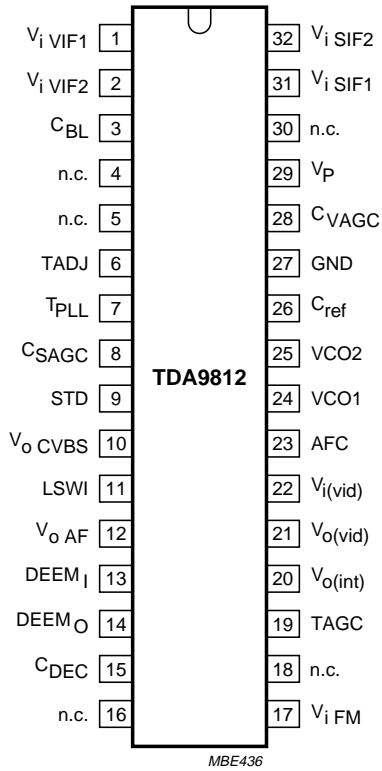

Fig.2 Pin configuration (SDIP32).

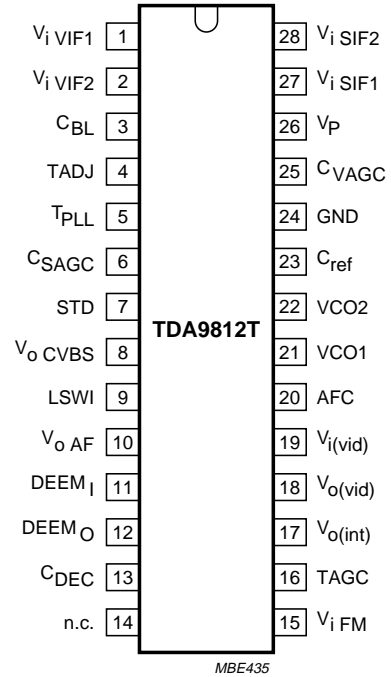

Fig.3 Pin configuration (SO28).

## Multistandard VIF-PLL and FM-PLL/AM demodulator

TDA9812

### FUNCTIONAL DESCRIPTION

#### Vision IF amplifier

The vision IF amplifier consists of three AC-coupled differential amplifier stages. Each differential stage comprises a feedback network controlled by emitter degeneration.

#### Tuner and VIF AGC

The AGC capacitor voltage is transferred to an internal IF control signal, and is fed to the tuner AGC to generate the tuner AGC output current (open-collector output). The tuner AGC take-over point can be adjusted. This allows the tuner and the SWIF filter to be matched to achieve the optimum IF input level.

The AGC detector charges/discharges the AGC capacitor to the required voltage for setting of VIF and tuner gain in order to keep the video signal at a constant level.

Therefore for negative video modulation the sync level and for positive video modulation the peak white level of the video signal is detected. In order to reduce the reaction time for positive modulation, where a very large time constant is needed, an additional level detector increases the discharging current of the AGC capacitor (fast mode) in the event of a decreasing VIF amplitude step. The additional level information is given by the black-level detector voltage.

#### Frequency-Phase detector (FPLL)

The VIF-amplifier output signal is fed into a frequency detector and into a phase detector via a limiting amplifier. During acquisition the frequency detector produces a DC current proportional to the frequency difference between the input and the VCO signal. After frequency lock-in the phase detector produces a DC current proportional to the phase difference between the VCO and the input signal. The DC current of either frequency detector or phase detector is converted into a DC voltage via the loop filter, which controls the VCO frequency. In the event of positive modulated signals the phase detector is gated by composite sync in order to avoid signal distortion for overmodulated VIF signals.

#### VCO, travelling wave divider and AFC

The VCO operates with a resonance circuit (with L and C in parallel) at double the PC frequency. The VCO is controlled by two integrated variable capacitors. The control voltage required to tune the VCO from its free-running frequency to actually double the PC frequency is generated by the Frequency-Phase detector and fed via the loop filter to the first variable capacitor (FPLL). This control voltage is amplified and additionally converted into a current which represents the AFC output signal. The VCO centre frequency can be decreased (required for L/L accent standard) by activating an additional internal capacitor. This is achieved by using the L/L accent switch. In this event the second variable capacitor can be controlled by a variable resistor at the L/L accent switch for setting the VCO centre frequency to the required L/L accent value. At centre frequency the AFC output current is equal to zero.

The oscillator signal is divided-by-two with a Travelling Wave Divider (TWD) which generates two differential output signals with a 90 degree phase difference independent of the frequency.

#### Video demodulator and amplifier

The video demodulator is realized by a multiplier which is designed for low distortion and large bandwidth. The vision IF input signal is multiplied with the 'in phase' signal of the travelling wave divider output. In the demodulator stage the video signal polarity can be switched in accordance with the TV standard.

The demodulator output signal is fed via an integrated low-pass filter for attenuation of the carrier harmonics to the video amplifier. The video amplifier is realized by an operational amplifier with internal feedback and high bandwidth. A low-pass filter is integrated to achieve an attenuation of the carrier harmonics for B/G and L standard. The standard dependent level shift in this stage delivers the same sync level for positive and negative modulation. The video output signal is 1 V (p-p) for nominal vision IF modulation.

## Multistandard VIF-PLL and FM-PLL/AM demodulator

TDA9812

### Video buffer

For an easy adaption of the sound traps an operational amplifier with internal feedback is used in the event of B/G and L standard. This amplifier is featured with a high bandwidth and 7 dB gain. The input impedance is adapted for operating in combination with ceramic sound traps. The output stage delivers a nominal 2 V (p-p) positive video signal. Noise clipping is provided.

### SIF amplifier and AGC for AM sound

The sound IF amplifier consists of two AC-coupled differential amplifier stages. Each differential stage comprises a controlled feedback network provided by emitter degeneration.

The SIF AGC detector is related to the SIF input signals (average level of AM carrier) and controls the SIF amplifier to provide a constant SIF signal to the AM demodulator. The SIF AGC reaction time is set to 'slow' for nominal video conditions. But with a decreasing VIF amplitude step the SIF AGC is set to 'fast' mode controlled by the VIF AGC detector.

### Intercarrier mixer

The intercarrier mixer is realized by a multiplier. The VIF amplifier output signal is fed to the intercarrier mixer and converted to intercarrier frequency by the regenerated picture carrier (VCO). The mixer output signal is fed via a high-pass for attenuation of the video signal components.

### AM demodulator

The AM demodulator is realized by a multiplier. The modulated SIF amplifier output signal is multiplied in phase with the limited (AM is removed) SIF amplifier output signal. The demodulator output signal is fed via an integrated low-pass filter for attenuation of the carrier harmonics to the AF amplifier.

### FM detector

The FM detector consists of a limiter, an FM-PLL and an AF amplifier. The limiter provides the amplification and limitation of the FM sound intercarrier signal before demodulation. The result is high sensitivity and AM suppression. The amplifier consists of 7 stages which are internally AC-coupled in order to minimize the DC offset and to save pins for DC decoupling.

The FM-PLL consists of an integrated relaxation oscillator, an integrated loop filter and a phase detector. The oscillator is locked to the FM intercarrier signal, output from the limiter. As a result of locking, the oscillator frequency tracks with the modulation of the input signal and the oscillator control voltage is superimposed by the AF voltage. The FM-PLL operates as an FM-demodulator

The AF amplifier consists of two parts:

- The AF preamplifier for FM sound is an operational amplifier with internal feedback, high gain and high common mode rejection. The AF voltage from the PLL demodulator, by principle a small output signal, is amplified by approximately 33 dB. The low-pass characteristic of the amplifier reduces the harmonics of the intercarrier signal at the sound output terminal, at which the de-emphasis network for FM sound is applied. An additional DC control circuit is implemented to keep the DC level constant, independent of process spread.
- The AF output amplifier (10 dB) provides the required output level by a rail-to-rail output stage. This amplifier makes use of an input selector for switching to AM, FM de-emphasis or mute state, controlled by the standard switching voltage and the mute switching voltage.

### Internal voltage stabilizer and $\frac{1}{2}V_P$ -reference

The bandgap circuit internally generates a voltage of approximately 1.25 V, independent of supply voltage and temperature. A voltage regulator circuit, connected to this voltage, produces a constant voltage of 3.6 V which is used as an internal reference voltage.

For all audio output signals the constant reference voltage cannot be used because large output signals are required. Therefore these signals refer to half the supply voltage to achieve a symmetrical headroom, especially for the rail-to-rail output stage. For ripple and noise attenuation the  $\frac{1}{2}V_P$  voltage has to be filtered via a low-pass filter by using an external capacitor together with an integrated resistor ( $f_g = 5$  Hz). For a fast setting to  $\frac{1}{2}V_P$  an internal start-up circuit is added.



# Multistandard VIF-PLL and FM-PLL/AM demodulator

TDA9812

## LIMITING VALUES

SDIP32

In accordance with the Absolute Maximum Rating System (IEC 134).

SYMBOL	PARAMETER	CONDITIONS	MIN.	MAX.	UNIT
$V_P$	supply voltage (pin 29)	maximum chip temperature of +120 °C; note 1	0	5.5	V
$V_i$	voltage at pins 1 to 9, 11 to 19, 22, 23 and 28 to 32		0	$V_P$	V
$t_{s(max)}$	maximum short-circuit time		–	10	s
$V_{19}$	tuner AGC output voltage		0	13.2	V
$T_{stg}$	storage temperature		–25	+150	°C
$T_{amb}$	operating ambient temperature		–20	+70	°C
$V_{esd}$	electrostatic handling voltage	note 2	–300	+300	V

## Notes

- $I_P = 110$  mA;  $T_{amb} = +70$  °C;  $R_{th\ j-a} = 60$  K/W for SDIP32 and  $R_{th\ j-a} = 80$  K/W for SO28.
- Charge device model class B: equivalent to discharging a 200 pF capacitor via a 0  $\Omega$  series resistor.

## THERMAL CHARACTERISTICS

SYMBOL	PARAMETER	VALUE	UNIT
$R_{th\ j-a}$	thermal resistance from junction to ambient in free air		
	SDIP32	60	K/W
	SO28	80	K/W

# Multistandard VIF-PLL and FM-PLL/AM demodulator

TDA9812

## CHARACTERISTICS

SDIP32 pinning;  $V_P = 5\text{ V}$ ;  $T_{amb} = +25\text{ °C}$ ; see Table 1 for input frequencies and level; input level  $V_{i\text{IF}1,2} = 10\text{ mV}$  RMS value (sync-level for B/G, peak white level for L); video modulation DSB; residual carrier B/G: 10%; L = 3%; video signal in accordance with "CCIR, line 17"; measurements taken in Fig.17 unless otherwise specified.

SYMBOL	PARAMETER	CONDITIONS	MIN.	TYP.	MAX.	UNIT
<b>Supply (pin 29)</b>						
$V_P$	supply voltage	note 1	4.5	5	5.5	V
$I_P$	supply current		82	96	110	mA
<b>Vision IF amplifier (pins 1 and 2)</b>						
$V_{i(\text{VIF})\text{(rms)}}$	input signal voltage sensitivity (RMS value)	B/G standard; -1 dB video at output	-	60	100	$\mu\text{V}$
$V_{i(\text{max})\text{(rms)}}$	maximum input signal voltage (RMS value)	B/G standard; +1 dB video at output	120	200	-	mV
$\Delta V_{o(\text{int})}$	internal IF amplitude difference between picture and sound carrier	within AGC range; B/G standard; $\Delta f = 5.5\text{ MHz}$	-	0.7	1	dB
$G_{\text{IF}}$	IF gain control range	see Figs 5 and 6	65	70	-	dB
$R_{i(\text{diff})}$	differential input resistance	note 2	1.7	2.2	2.7	$\text{k}\Omega$
$C_{i(\text{diff})}$	differential input capacitance	note 2	1.2	1.7	2.5	pF
$V_{1/2}$	DC input voltage		-	3.4	-	V
<b>True synchronous video demodulator; see note 3</b>						
$f_{\text{VCO}(\text{max})}$	maximum oscillator frequency for carrier regeneration	$f = 2f_{\text{pc}}$	125	130	-	MHz
$\Delta f_{\text{VCO}}$	oscillator drift (free-running) as a function of temperature	$I_{\text{AFC}} = 0$ ; note 4	-20	-	+20	ppm/K
$V_{0\text{ref}(\text{rms})}$	oscillator voltage swing at pins 24 and 25 (RMS value)	B/G and L standard	70	100	130	mV
		L/L accent standard	45	65	85	mV
$\Delta f_{\text{pc}(\text{capt})}$	vision carrier capture frequency range	B/G and L standard	$\pm 1.5$	$\pm 2.0$	-	MHz
		L/L accent standard; $f_{\text{pc}} = 33.9\text{ MHz}$ ; $R_{11} = 5.6\text{ k}\Omega$	$\pm 1.0$	$\pm 1.3$	-	MHz
$\Delta f_{\text{pc}(\text{ff})}$	vision carrier frequency (free-running) accuracy	L/L accent standard; $f_{\text{pc}} = 33.9\text{ MHz}$ ; $R_{11} = 5.6\text{ k}\Omega$	-	$\pm 200$	$\pm 400$	kHz
$\Delta f_{\text{pc}(\text{alg})}$	L/L accent alignment frequency range	$I_{\text{AFC}} = 0$	$\pm 400$	$\pm 600$	-	kHz
$t_{\text{acqu}}$	acquisition time	BL = 60 kHz; note 5	-	-	30	ms
$V_{i(\text{VIF})\text{(rms)}}$	VIF input signal voltage sensitivity for PLL to be locked (RMS value; pins 1 and 2)	maximum IF gain; note 6	-	30	70	$\mu\text{V}$
$I_{\text{PLL}(\text{os})}$	FPLL offset current at pin 7	note 7	-	-	$\pm 4.5$	$\mu\text{A}$

# Multistandard VIF-PLL and FM-PLL/AM demodulator

TDA9812

SYMBOL	PARAMETER	CONDITIONS	MIN.	TYP.	MAX.	UNIT
<b>Composite video amplifier (pin 21; sound carrier OFF)</b>						
$V_{o \text{ video(p-p)}}$	output signal voltage (peak-to-peak value)	see Fig.13	0.88	1.0	1.12	V
$V_{21(\text{sync})}$	sync voltage level	B/G and L standard	–	1.5	–	V
$V_{21(\text{clu})}$	upper video clipping voltage level		$V_P - 1.1$	$V_P - 1$	–	V
$V_{21(\text{cll})}$	lower video clipping voltage level		–	0.3	0.4	V
$R_{21}$	output resistance	note 2	–	–	10	$\Omega$
$I_{\text{int } 21}$	internal DC bias current for emitter-follower		1.6	2.0	–	mA
$I_{21(\text{max})(\text{sink})}$	maximum AC and DC output sink current		1.0	–	–	mA
$I_{21(\text{max})(\text{source})}$	maximum AC and DC output source current		2.0	–	–	mA
$B_{-1}$	–1 dB video bandwidth	B/G and L standard; $C_L < 50 \text{ pF}$ ; $R_L > 1 \text{ k}\Omega$ ; AC load	5	6	–	MHz
$B_{-3}$	–3 dB video bandwidth	B/G and L standard; $C_L < 50 \text{ pF}$ ; $R_L > 1 \text{ k}\Omega$ ; AC load	7	8	–	MHz
$\alpha_H$	suppression of video signal harmonics	$C_L < 50 \text{ pF}$ ; $R_L > 1 \text{ k}\Omega$ ; AC load; note 8a	35	40	–	dB
PSRR	power supply ripple rejection at pin 21	video signal; grey level; see Fig.16 B/G standard L standard	32 26	35 30	– –	dB dB
<b>CVBS buffer amplifier (only) and noise clipper (pins 10 and 22)</b>						
$R_{22}$	input resistance	note 2	2.6	3.3	4.0	$\text{k}\Omega$
$C_{22}$	input capacitance	note 2	1.4	2	3.0	pF
$V_{22}$	DC input voltage		1.5	1.8	2.1	V
$G_v$	voltage gain	B/G and L standard; note 9	6.5	7	7.5	dB
$V_{10(\text{clu})}$	upper video clipping voltage level		3.9	4.0	–	V
$V_{10(\text{cll})}$	lower video clipping voltage level		–	1.0	1.1	V
$R_{10}$	output resistance	note 2	–	–	10	$\Omega$
$I_{\text{int } 10}$	DC internal bias current for emitter-follower		2.0	2.5	–	mA
$I_{10(\text{max})(\text{sink})}$	maximum AC and DC output sink current		1.4	–	–	mA
$I_{10(\text{max})(\text{source})}$	maximum AC and DC output source current		2.4	–	–	mA

# Multistandard VIF-PLL and FM-PLL/AM demodulator

TDA9812

SYMBOL	PARAMETER	CONDITIONS	MIN.	TYP.	MAX.	UNIT
B <sub>-1</sub>	-1 dB video bandwidth	B/G and L standard; C <sub>L</sub> < 20 pF; R <sub>L</sub> > 1 kΩ; AC load	8.4	11	–	MHz
B <sub>-3</sub>	-3 dB video bandwidth	B/G and L standard; C <sub>L</sub> < 20 pF; R <sub>L</sub> > 1 kΩ; AC load	11	14	–	MHz
<b>Measurements from IF input to CVBS output (pin 10; 330 Ω between pins 21 and 22, sound carrier OFF)</b>						
V <sub>o CVBS(p-p)</sub>	CVBS output signal voltage on pin 10 (peak-to-peak value)	note 9	1.7	2.0	2.3	V
V <sub>o CVBS(sync)</sub>	sync voltage level	B/G standard	–	1.35	–	V
		L standard	–	1.35	–	V
ΔV <sub>o</sub>	deviation of CVBS output signal voltage at B/G	50 dB gain control	–	–	0.5	dB
		30 dB gain control	–	–	0.1	dB
ΔV <sub>o(b/BG)</sub>	black level tilt in B/G standard	gain variation; note 10	–	–	1	%
ΔV <sub>o(b/L)</sub>	black level tilt for worst case in L standard	vision carrier modulated by test line (VITS) only; gain variation; note 10	–	–	1.9	%
ΔG <sub>diff</sub>	differential gain	"CCIR, line 330"	–	2	5	%
Δφ <sub>diff</sub>	differential phase	"CCIR, line 330"	–	1	2	deg
B <sub>-1</sub>	-1 dB video bandwidth	B/G and L standard; C <sub>L</sub> < 20 pF; R <sub>L</sub> > 1 kΩ; AC load	5	6	–	MHz
B <sub>-3</sub>	-3 dB video bandwidth	B/G and L standard; C <sub>L</sub> < 20 pF; R <sub>L</sub> > 1 kΩ; AC load	7	8	–	MHz
S/N (W)	weighted signal-to-noise ratio	see Figs 9 and 10; note 11	56	60	–	dB
S/N	unweighted signal-to-noise ratio	see Figs 9 and 10; note 11	49	53	–	dB
IMα <sub>1.1</sub>	intermodulation attenuation at 'blue'	f = 1.1 MHz; see Fig.11; note 12	58	64	–	dB
	intermodulation attenuation at 'yellow'	f = 1.1 MHz; see Fig.11; note 12	60	66	–	dB
IMα <sub>3.3</sub>	intermodulation attenuation at 'blue'	f = 3.3 MHz; see Fig.11; note 12	58	64	–	dB
	intermodulation attenuation at 'yellow'	f = 3.3 MHz; see Fig.11; note 12	59	65	–	dB
α <sub>c(rms)</sub>	residual vision carrier (RMS value)	B/G and L standard; fundamental wave and harmonics	–	2	5	mV
α <sub>H(sup)</sub>	suppression of video signal harmonics	note 8a	35	40	–	dB
α <sub>H(spur)</sub>	spurious elements	note 8b	40	–	–	dB

# Multistandard VIF-PLL and FM-PLL/AM demodulator

TDA9812

SYMBOL	PARAMETER	CONDITIONS	MIN.	TYP.	MAX.	UNIT
PSRR	power supply ripple rejection at pin 10	video signal; grey level; see Fig.16				
		B/G standard	25	28	–	dB
		L standard	20	23	–	dB
<b>VIF-AFC detector (pin 28)</b>						
$I_{28}$	charging current	B/G and L standard; note 10	0.75	1	1.25	mA
	additional charging current	L standard in event of missing VITS pulses and no white video content	1.9	2.5	3.1	$\mu$ A
	discharging current	B/G standard	15	20	25	$\mu$ A
		normal mode L	225	300	375	nA
	fast mode L	30	40	50	$\mu$ A	
$t_{resp}$	AGC response to an increasing VIF step	B/G and L standard; note 13	–	0.05	0.1	ms/dB
	AGC response to a decreasing VIF step	B/G standard	–	2.2	3.5	ms/dB
		fast mode L	–	1.1	1.8	ms/dB
		normal mode L; note 13	–	150	240	ms/dB
$\Delta$ IF	VIF amplitude step for activating fast AGC mode	L standard	–2	–6	–10	dB
$V_3$	threshold voltage level additional charging current	see Fig.13				
		L standard	–	1.95	–	V
		L standard; fast mode L	–	1.65	–	V
<b>Tuner AGC (pin 19)</b>						
$V_{i(rms)}$	IF input signal voltage for minimum starting point of tuner take-over (RMS value)	input at pins 1 and 2; $R_{TOP} = 22 \text{ k}\Omega$ ; $I_{19} = 0.4 \text{ mA}$	–	2	5	mV
	IF input signal voltage for maximum starting point of tuner take-over (RMS value)	input at pins 1 and 2; $R_{TOP} = 0 \text{ }\Omega$ ; $I_{19} = 0.4 \text{ mA}$	50	100	5	mV
$V_{19}$	permissible output voltage	from external source; note 2	–	–	13.2	V
	saturation voltage	$I_{19} = 1.5 \text{ mA}$	–	–	0.2	V
$\Delta V_{19}$	variation of take-over point by temperature	$I_{19} = 0.4 \text{ mA}$	–	0.03	0.07	dB/K
$I_{19(sink)}$	sink current	no tuner gain reduction; see Figs 5 and 6				
		$V_{19} = 12 \text{ V}$	–	–	2.5	$\mu$ A
		$V_{19} = 13.2 \text{ V}$	–	–	5	$\mu$ A
	maximum tuner gain reduction		1.5	2	2.6	mA
$\Delta G_{IF}$	IF slip by automatic gain control	tuner gain current from 20 to 80%	–	6	8	dB

# Multistandard VIF-PLL and FM-PLL/AM demodulator

TDA9812

SYMBOL	PARAMETER	CONDITIONS	MIN.	TYP.	MAX.	UNIT
<b>AFC circuit (pin 23); see Fig.12 and note 14</b>						
S	control steepness $\Delta I_{23}/\Delta f$	note 15	0.5	0.72	1.0	$\mu\text{A}/\text{kHz}$
$\Delta f_{IF}$	frequency variation by temperature	$I_{AFC} = 0$ ; note 5	-20	-	+20	ppm/K
$V_{23}$	output voltage upper limit	see Fig.12	$V_P - 0.6$	$V_P - 0.3$	-	V
	output voltage lower limit	see Fig.12	-	0.3	0.6	V
$I_{23(\text{source})}$	output source current		150	200	250	$\mu\text{A}$
$I_{23(\text{sink})}$	output sink current		150	200	250	$\mu\text{A}$
$\Delta I_{23(p-p)}$	residual video modulation current (peak-to-peak value)	B/G and L standard	-	20	30	$\mu\text{A}$
<b>Sound IF amplifier (pins 31 and 32)</b>						
$V_{i(\text{SIF})(\text{rms})}$	input signal voltage sensitivity (RMS value)	-3 dB video at AF output; pin 12	-	70	100	$\mu\text{V}$
$V_{i(\text{max})(\text{rms})}$	maximum input signal voltage (RMS value)	+1 dB video at AF output; pin 12	80	140	-	mV
$G_{\text{SIF}}$	SIF gain control range	see Figs 7 and 8	60	66	-	dB
$R_{i(\text{diff})}$	differential input resistance	note 2	1.7	2.2	2.7	k $\Omega$
$C_{i(\text{diff})}$	differential input capacitance	note 2	1.2	1.7	2.5	pF
$V_{31/32}$	DC input voltage		-	3.4	-	V
$\alpha_{\text{SIF/VIF}}$	crosstalk attenuation between SIF and VIF input	between pins 1 and 2 and pins 31 and 32; note 16	50	-	-	dB
<b>SIF-AFC detector (pin 8)</b>						
$I_8$	charging current		0.8	1.2	1.6	mA
	discharging current	normal mode AM	1	1.4	1.8	$\mu\text{A}$
		fast mode AM	60	85	110	$\mu\text{A}$
<b>Intercarrier mixer (B/G standard) (pin 20)</b>						
$V_{o(\text{rms})}$	IF intercarrier level (RMS value)	SC; note 17	-	see formula	-	mV
$B_{-3}$	-3 dB intercarrier bandwidth	upper limit	7.5	9	-	MHz
$\alpha_{c(\text{rms})}$	residual sound carrier (RMS value)	fundamental wave and harmonics	-	2	-	mV
$R_{20}$	output resistance	note 2	-	-	25	$\Omega$
$V_{20}$	DC output voltage		-	2.0	-	V
$I_{\text{int}20}$	DC internal bias current for emitter-follower		1.5	1.9	-	mA
$I_{20(\text{max})(\text{sink})}$	maximum AC and DC output sink current		1.1	1.5	-	mA
$I_{20(\text{max})(\text{source})}$	maximum AC and DC output source current		3.0	3.5	-	mA

# Multistandard VIF-PLL and FM-PLL/AM demodulator

TDA9812

SYMBOL	PARAMETER	CONDITIONS	MIN.	TYP.	MAX.	UNIT
<b>Limiting amplifier (pin 17); see note 18</b>						
$V_{i\text{ FM(rms)}}$	input signal voltage for lock-in (RMS value)		–	–	100	$\mu\text{V}$
$V_{i\text{ FM(rms)}}$	input signal voltage (RMS value)	$\left(\frac{S+N}{N}\right) = 40\text{ dB}$	–	300	400	$\mu\text{V}$
	allowed input signal voltage (RMS value)		200	–	–	mV
$R_{17}$	input resistance	note 2	480	600	720	$\Omega$
$V_{17}$	DC input voltage		–	2.8	–	V
<b>FM-PLL detector</b>						
$f_{i\text{ FM(catch)}}$	catching range of PLL	upper limit	7.0	–	–	MHz
		lower limit	–	–	4.0	MHz
$f_{i\text{ FM(hold)}}$	holding range of PLL	upper limit	9.0	–	–	MHz
		lower limit	–	–	3.5	MHz
$t_{\text{acq}}$	acquisition time		–	–	4	$\mu\text{s}$
<b>FM operation (B/G standard) (pin 12); see notes 18 and 1818</b>						
$V_{o\text{ AF12(rms)}}$	AF output signal voltage (RMS value)	without de-emphasis; short-circuit from pin 13 to pin 14; 27 kHz (54% FM deviation); see Fig.17 and note 19				
		$R_x = 470\ \Omega$ $R_x = 0\ \Omega$	200 400	250 500	300 600	mV mV
$V_{o\text{ AF12(cl)}}$	AF output clipping signal voltage level	THD < 1.5%	1.3	1.4	–	V
$\Delta f_{\text{AF}}$	frequency deviation	THD < 1.5%; note 19	–	–	53	kHz
$\Delta V_o$	temperature drift of AF output signal voltage		–	3	7	$10^{-3}\text{ dB/K}$
$V_{15}$	DC voltage at decoupling capacitor	voltage dependent on VCO frequency; note 20	1.2	–	3.0	V
$R_{12}$	output resistance	note 2	–	–	100	$\Omega$
$V_{12}$	DC output voltage	tracked with supply voltage	–	$\frac{1}{2}V_P$	–	V
$I_{12(\text{max})(\text{sink})}$	maximum AC and DC output sink current		–	–	1.1	mA
$I_{12(\text{max})(\text{source})}$	maximum AC and DC output source current		–	–	1.1	mA
$B_{-3}$	–3 dB video bandwidth	without de-emphasis; short-circuit from pin 13 to pin 14	100	125	–	kHz
THD	total harmonic distortion		–	0.15	0.5	%

Multistandard VIF-PLL and  
FM-PLL/AM demodulator

TDA9812

SYMBOL	PARAMETER	CONDITIONS	MIN.	TYP.	MAX.	UNIT
S/N (W)	weighted signal-to-noise ratio	FM-PLL only; with 50 $\mu$ s de-emphasis; 27 kHz (54% FM deviation); "CCIR 468-4"	55	60	–	dB
$\alpha_{c(rms)}$	residual sound carrier (RMS value)	fundamental wave and harmonics	–	–	75	mV
$\alpha_{AM}$	AM suppression	50 $\mu$ s de-emphasis; AM: f = 1 kHz; m = 0.3 refer to 27 kHz (54% FM deviation)	46	50	–	dB
$\alpha_{12}$	mute attenuation of AF signal	B/G and L standard	70	75	–	dB
$\Delta V_{12}$	DC jump voltage of AF output terminal for switching AF output to mute state and vice versa	FM-PLL in lock mode	–	$\pm 50$	$\pm 150$	mV
PSRR	power supply ripple rejection at pin 12	$R_x = 470 \Omega$ ; see Fig.16	26	30	–	dB
<b>AF performance for FM operation (B/G standard);</b> see notes 21, 22 and 23; Table 1						
S/N (W)	weighted signal-to-noise ratio	PC/SC ratio at pins 1 and 2; 27 kHz (54% FM deviation); "CCIR 468-4"	27	–	–	dB
		black picture	45	51	–	dB
		white picture	45	51	–	dB
		6 kHz sine wave (black to white modulation)	40	46	–	dB
		sound carrier subharmonics; f = 2.75 MHz $\pm 3$ kHz	35	40	–	dB
<b>AM operation (L standard) (pin 12);</b> see note 24						
$V_{o AF12(rms)}$	AF output signal voltage (RMS value)	54% modulation	400	500	600	mV
THD	total harmonic distortion	54% modulation; see Fig.15	–	0.5	1.0	%
$B_{-3}$	–3 dB AF bandwidth		100	125	–	kHz
S/N (W)	weighted signal-to-noise ratio	"CCIR 468-4"; see Fig.14	47	53	–	dB
$V_{12}$	DC potential voltage	tracked with supply voltage	–	$\frac{1}{2}V_P$	–	V
PSRR	power supply ripple rejection	see Fig.16	22	25	–	dB



# Multistandard VIF-PLL and FM-PLL/AM demodulator

TDA9812

SYMBOL	PARAMETER	CONDITIONS	MIN.	TYP.	MAX.	UNIT
<b>Standard switch (pin 9); see also Table 2</b>						
V <sub>9</sub>	DC potential voltage for preferred settings					
	input voltage for negative standard	B/G standard; note 25	2.8	–	V <sub>P</sub>	V
	input voltage for negative standard	negative AGC OFF	1.3	–	2.3	V
	input voltage for positive standard	L standard	0	–	0.8	V
I <sub>IL</sub>	LOW level input current	V <sub>9</sub> = 0 V	190	250	310	μA
<b>L/L accent switch (pin 11)</b>						
V <sub>11</sub>	DC potential voltage for L standard VCO frequency switching					
	L standard	note 25	2.8	–	V <sub>P</sub>	V
	L/L accent standard and alignment		–	–	2.0	V
I <sub>IL</sub>	LOW level input current	V <sub>11</sub> = 0 V	150	200	250	μA

## Notes

- Values of video and sound parameters are decreased at V<sub>P</sub> = 4.5 V.
- This parameter is not tested during production and is only given as application information for designing the television receiver.
- Loop bandwidth BL = 60 kHz (natural frequency f<sub>n</sub> = 15 kHz; damping factor d = 2; calculated with sync level within gain control range). Resonance circuit of VCO: Q<sub>0</sub> > 50; C<sub>ext</sub> = 8.2 pF ±0.25 pF; C<sub>int</sub> ≈ 8.5 pF (loop voltage approximately 2.7 V).
- Temperature coefficient of external LC-circuit is equal to zero.
- V<sub>iIF</sub> = 10 mV RMS; Δf = 1 MHz (VCO frequency offset related to picture carrier frequency); white picture video modulation.
- V<sub>iIF</sub> signal for nominal video signal.
- Offset current measured between pin 7 and half of supply voltage (V<sub>P</sub> = 2.5 V) under the following conditions: no input signal at VIF input (pins 1 and 2) and VIF amplifier gain at minimum (V<sub>28</sub> = V<sub>P</sub>). Due to sample-and-hold mode of the FPLL in L standard, the leakage current of the loop filter capacitor (C = 220 nF) should not exceed 500 nA.
- Measurements taken with SAW filter G1962 (sound shelf: 20 dB); loop bandwidth BL = 60 kHz.
  - Modulation VSB; sound carrier OFF; f<sub>video</sub> > 0.5 MHz.
  - Sound carrier ON; SIF SAW filter L9453; f<sub>video</sub> = 10 kHz to 10 MHz.
- The 7 dB buffer gain accounts for 1 dB loss in the sound trap. Buffer output signal is typical 2 V (p-p), in event of CVBS video amplifier output typical 1 V (p-p). If no sound trap is applied a 330 Ω resistor must be connected from output to input (from pin 21 to pin 22).
- The leakage current of the AGC capacitor should not exceed 1 μA at B/G standard respectively 10 nA current at L standard. Larger currents will increase the tilt.
- S/N is the ratio of black-to-white amplitude to the black level noise voltage (RMS value, pin 10). B = 5 MHz weighted in accordance with "CCIR 567".

## Multistandard VIF-PLL and FM-PLL/AM demodulator

TDA9812

12. The intermodulation figures are defined:  $\alpha_{1,1} = 20 \log (V_0 \text{ at } 4.4 \text{ MHz} / V_0 \text{ at } 1.1 \text{ MHz}) + 3.6 \text{ dB}$ ;  $\alpha_{1,1}$  value at 1.1 MHz referenced to black/white signal;  $\alpha_{3,3} = 20 \log (V_0 \text{ at } 4.4 \text{ MHz} / V_0 \text{ at } 3.3 \text{ MHz})$ ;  $\alpha_{3,3}$  value at 3.3 MHz referenced to colour carrier.
13. Response speed valid for a VIF input level range of 200  $\mu\text{V}$  up to 70 mV.
14. To match the AFC output signal to different tuning systems a current source output is provided. The test circuit is given in Fig.12. The AFC-steepness can be changed by the resistors at pin 23.
15. Depending on the ratio  $\Delta C/C_0$  of the LC resonant circuit of VCO ( $Q > 50$ ; see note 3;  $C_0 = C_{\text{int}} + C_{\text{ext}}$ ).
16. Source impedance: 2.3 k $\Omega$  in parallel to 12 pF (SAW filter);  $f_{\text{IF}} = 38.9 \text{ MHz}$ .
17. The intercarrier output signal at pin 20 can be calculated by the following formula taking into account the video output signal at pin 21 ( $V_{\text{o video(p-p)}} = 1 \text{ V}$  typical) as a reference:

$$V_{\text{o(rms)}} = 1V_{\text{(p-p)}} \times \frac{1}{2\sqrt{2}} \times 10^{\frac{\frac{V_{\text{iSC}}}{V_{\text{iPC}}} \text{ (dB)} + 6 \text{ dB} \pm 3 \text{ dB}}{20}}$$

with  $\frac{1}{2\sqrt{2}}$  = correction term for RMS value,

$\frac{V_{\text{iSC}}}{V_{\text{iPC}}} \text{ (dB)}$  = sound-to-picture carrier ratio at VIF input (pins 1 and 2) in dB,

6 dB = correction term of internal circuitry

and  $\pm 3 \text{ dB}$  = tolerance of video output and intercarrier output amplitude  $V_{\text{o(rms)}}$ .

Example: SAW filter G1962 (sound shelf: 20 dB)  $\Rightarrow \frac{V_{\text{iSC}}}{V_{\text{iPC}}} = -27 \text{ dB} \Rightarrow V_{\text{o(rms)}} = 32 \text{ mV}$  typical.

18. Input level for second IF from an external generator with 50  $\Omega$  source impedance. AC-coupled with 10 nF capacitor,  $f_{\text{mod}} = 1 \text{ kHz}$ , 27 kHz (54% FM deviation) of audio references. A VIF/SIF input signal is not permitted. Pins 8 and 28 have to be connected to positive supply voltage for minimum IF gain. S/N and THD measurements are taken at 50  $\mu\text{s}$  de-emphasis.  
Second IF input level 10 mV RMS.
19. Measured with an FM deviation of 27 kHz the typical AF output signal is 500 mV RMS ( $R_x = 0 \Omega$ ; see Fig.17). By using  $R_x = 470 \Omega$  the AF output signal is attenuated by 6 dB (250 mV RMS). For handling an FM deviation of more than 53 kHz the AF output signal has to be reduced by using  $R_x$  in order to avoid clipping (THD < 1.5%). For an FM deviation up to 100 kHz an attenuation of 6 dB is recommended with  $R_x = 470 \Omega$ .
20. The leakage current of the decoupling capacitor (2.2  $\mu\text{F}$ ) should not exceed 1  $\mu\text{A}$ .
21. For all S/N measurements the used vision IF modulator has to meet the following specifications:  
Incidental phase modulation for black-to-white jump less than 0.5 degrees.  
Picture-to-sound carrier ratio; PC/SC = 13 dB; (transmitter).  
Sound shelf of VIF SAW filter: minimum 20 dB.
22. Measurements taken with SAW filter K6256 (Siemens) for vision and sound IF (sound shelf: 20 dB). Input level  $V_{\text{i SIF}} = 10 \text{ mV}$  RMS, 27 kHz (54% FM deviation).
23. The PC/SC ratio at pins 1 and 2 is calculated as the addition of TV transmitter PC/SC ratio and SAW filter PC/SC ratio. This PC/SC ratio is necessary to achieve the S/N(W) values as noted. A different PC/SC ratio will change these values.
24. Measurements taken with SAW filter L9453 (Siemens) for AM sound IF (suppressed picture carrier).
25. The input voltage has to be  $V > 2.8 \text{ V}$ , or open-circuit.

# Multistandard VIF-PLL and FM-PLL/AM demodulator

TDA9812

**Table 1** Input frequencies and carrier ratios

DESCRIPTION	SYMBOL	B/G STANDARD	L STANDARD	L/L ACCENT STANDARD	UNIT
Picture carrier	$f_{pc}$	38.9	38.9	33.9	MHz
Sound carrier	$f_{sc}$	33.4	32.4	40.4	MHz
Picture-to-sound carrier ratio	SC	13	10	10	dB

**Table 2** Switch logic

STANDARD SWITCH	SELECTED STANDARD	VIDEO POLARITY	FM-PLL	AF-AMPLIFIER
2.8 V to $V_P$	B/G	negative	ON	FM
1.3 to 2.3 V	B/G, with external VIF AGC	negative	ON	FM
0 to 0.8 V	L	positive	OFF	AM

Multistandard VIF-PLL and FM-PLL/AM demodulator

TDA9812

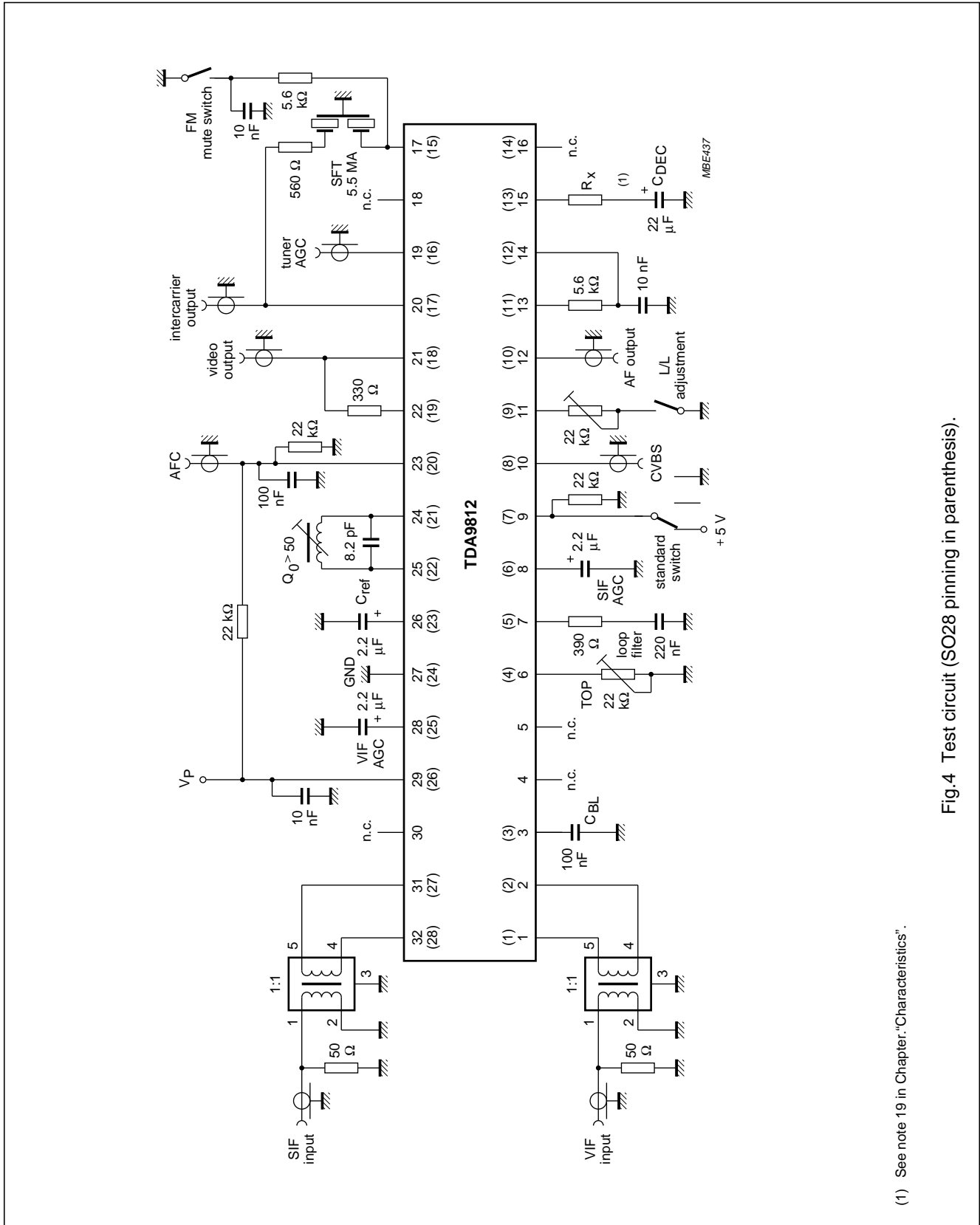
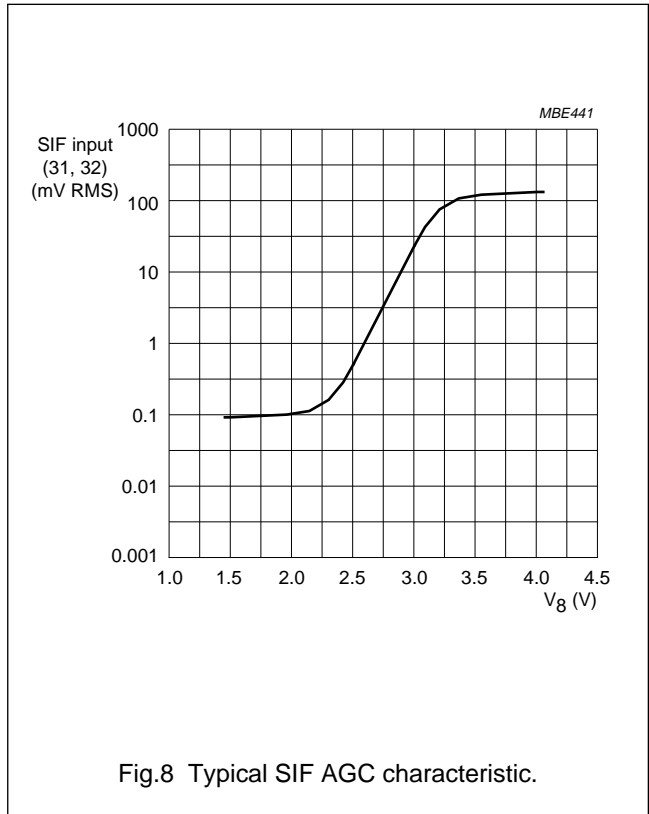
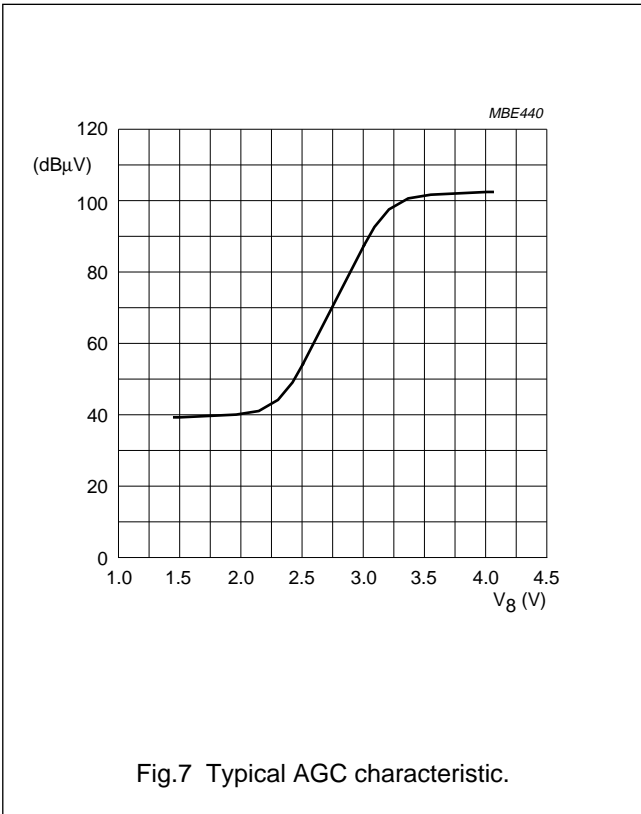
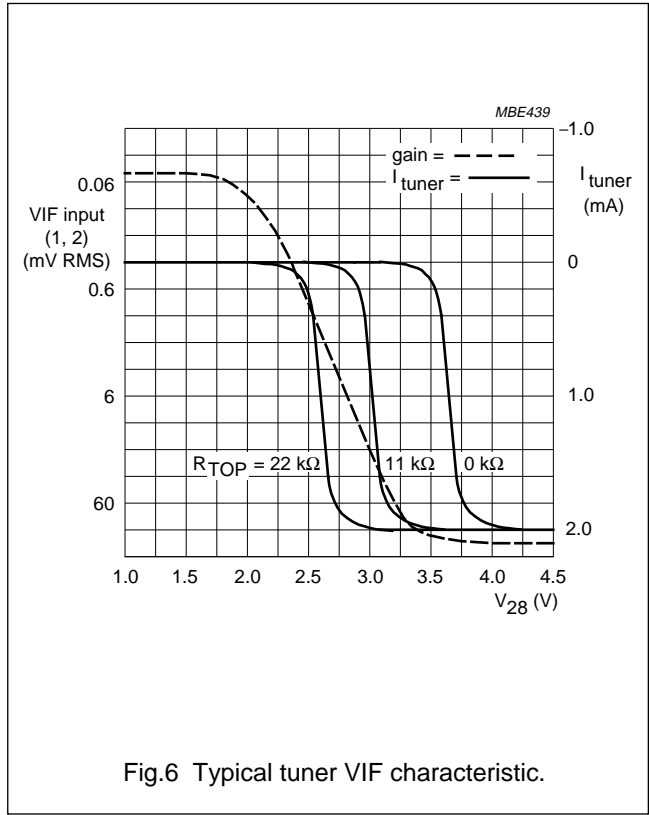
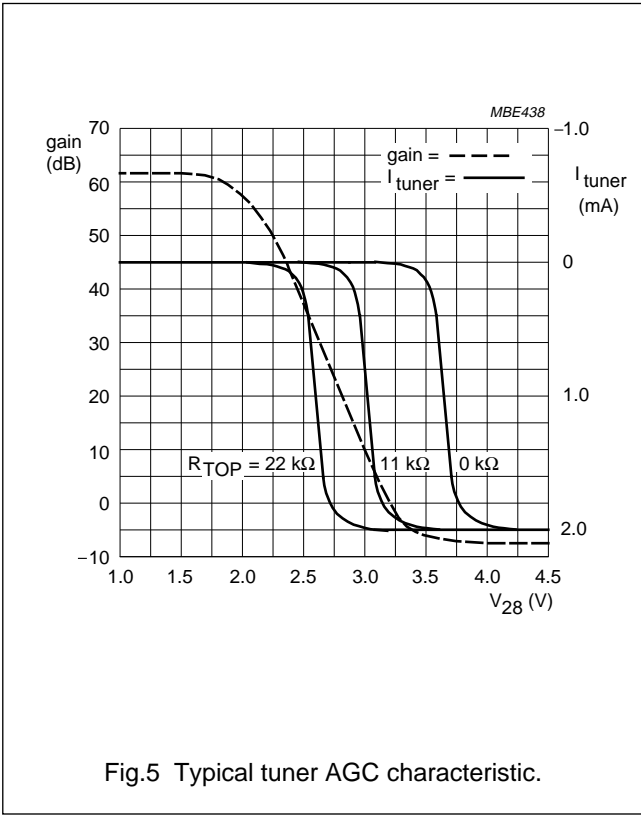

Fig.4 Test circuit (SO28 pinning in parenthesis).

(1) See note 19 in Chapter "Characteristics".

# Multistandard VIF-PLL and FM-PLL/AM demodulator

## TDA9812



Multistandard VIF-PLL and FM-PLL/AM demodulator

TDA9812

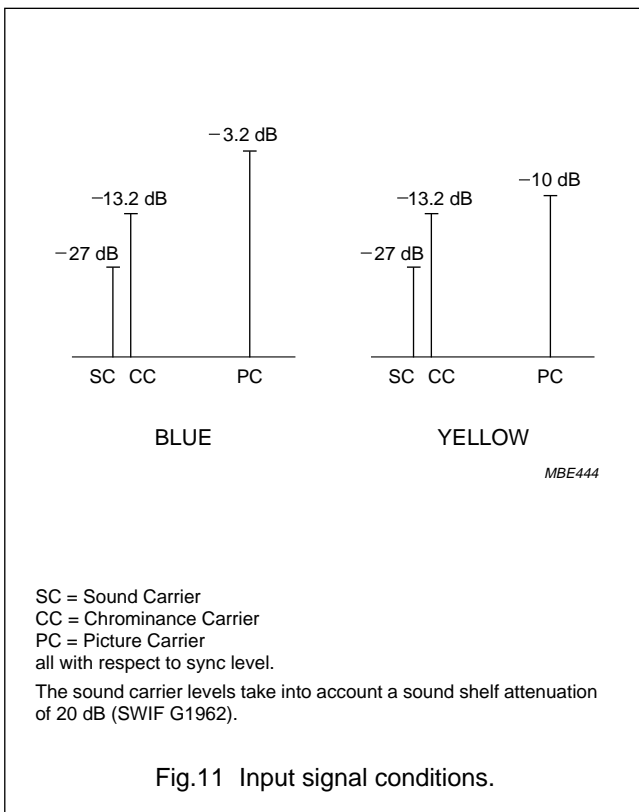
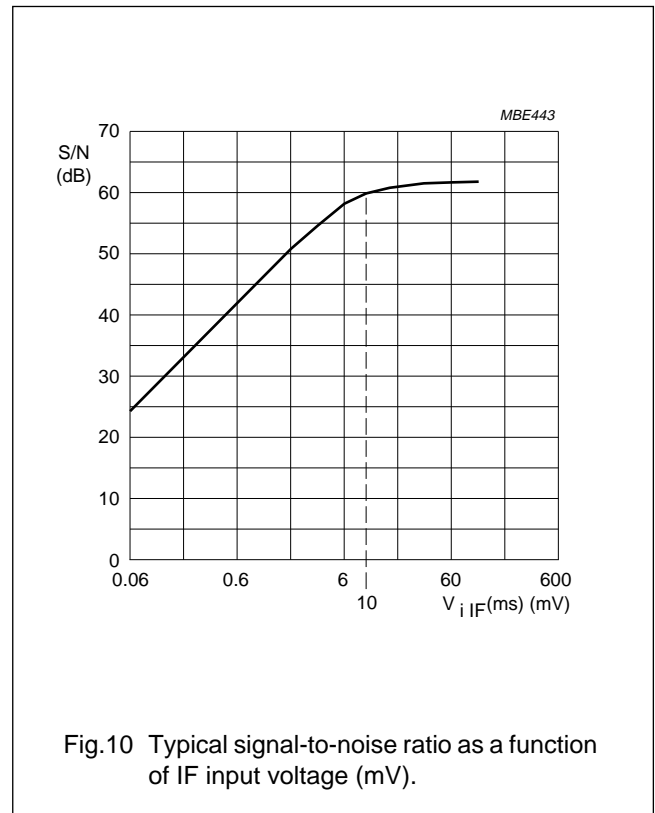
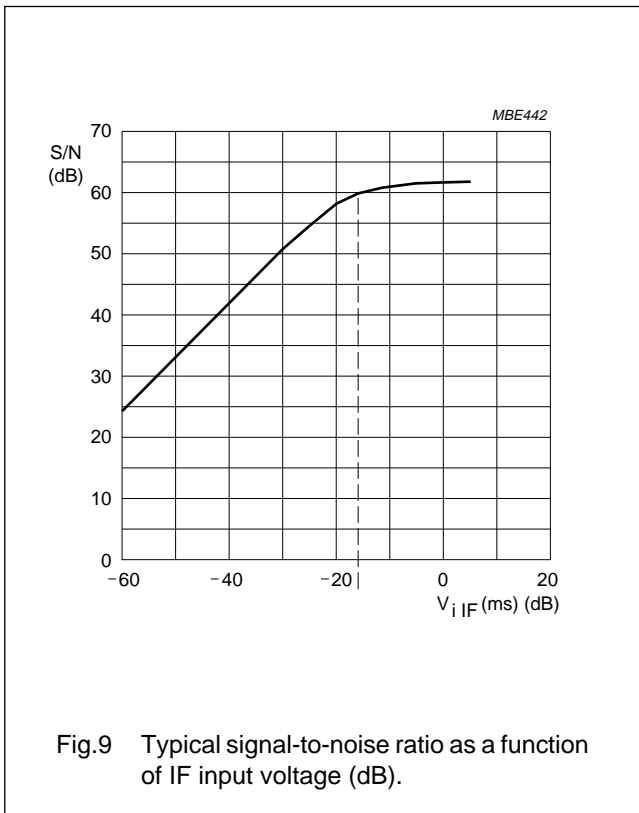

Multistandard VIF-PLL and FM-PLL/AM demodulator

TDA9812

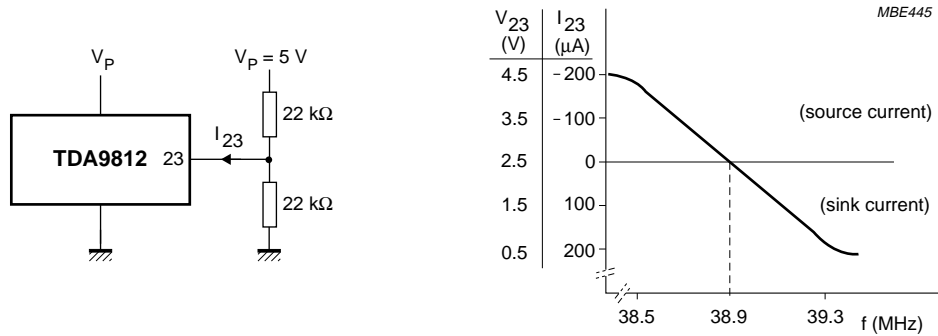

Fig.12 Measurement conditions and typical AFC characteristic.

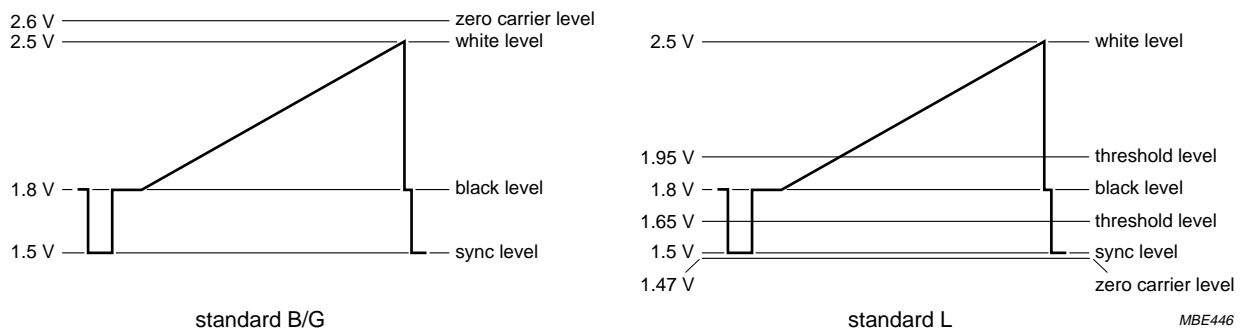
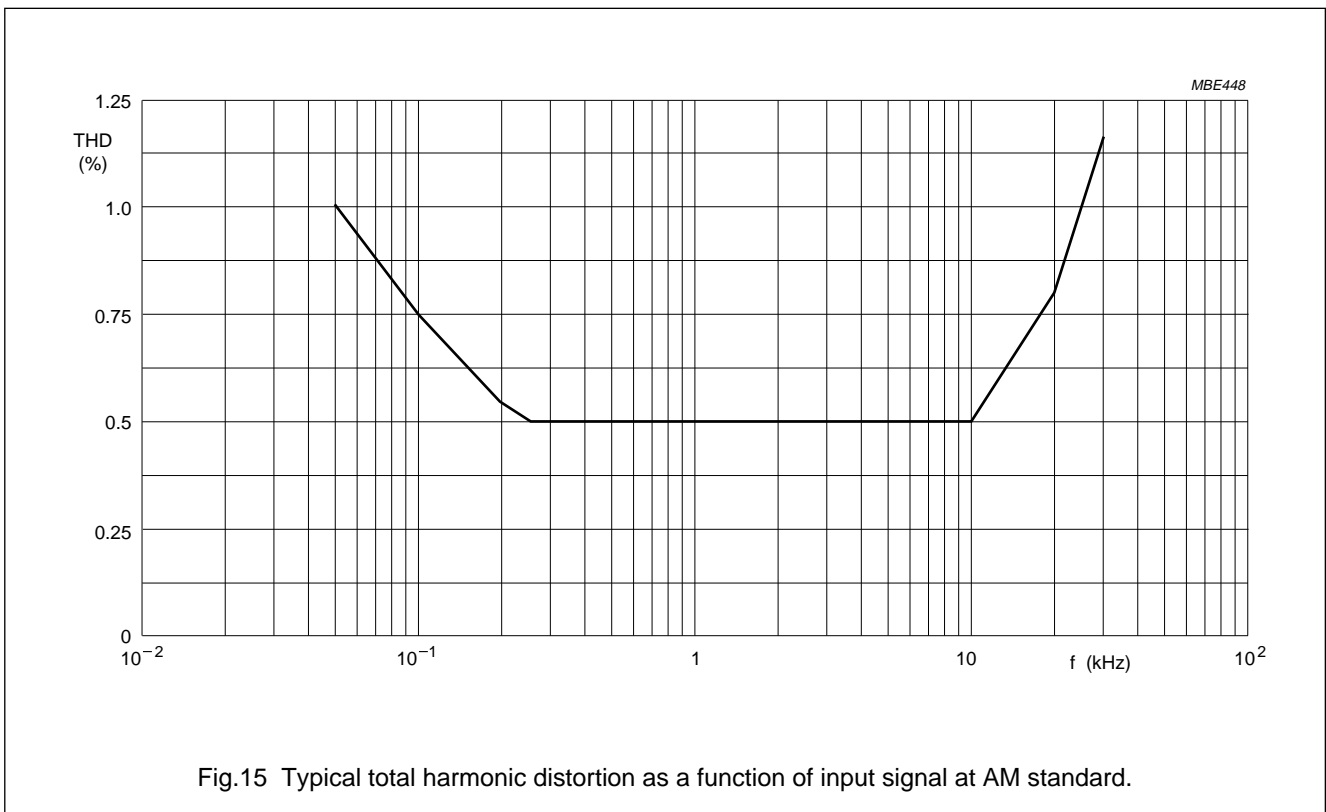
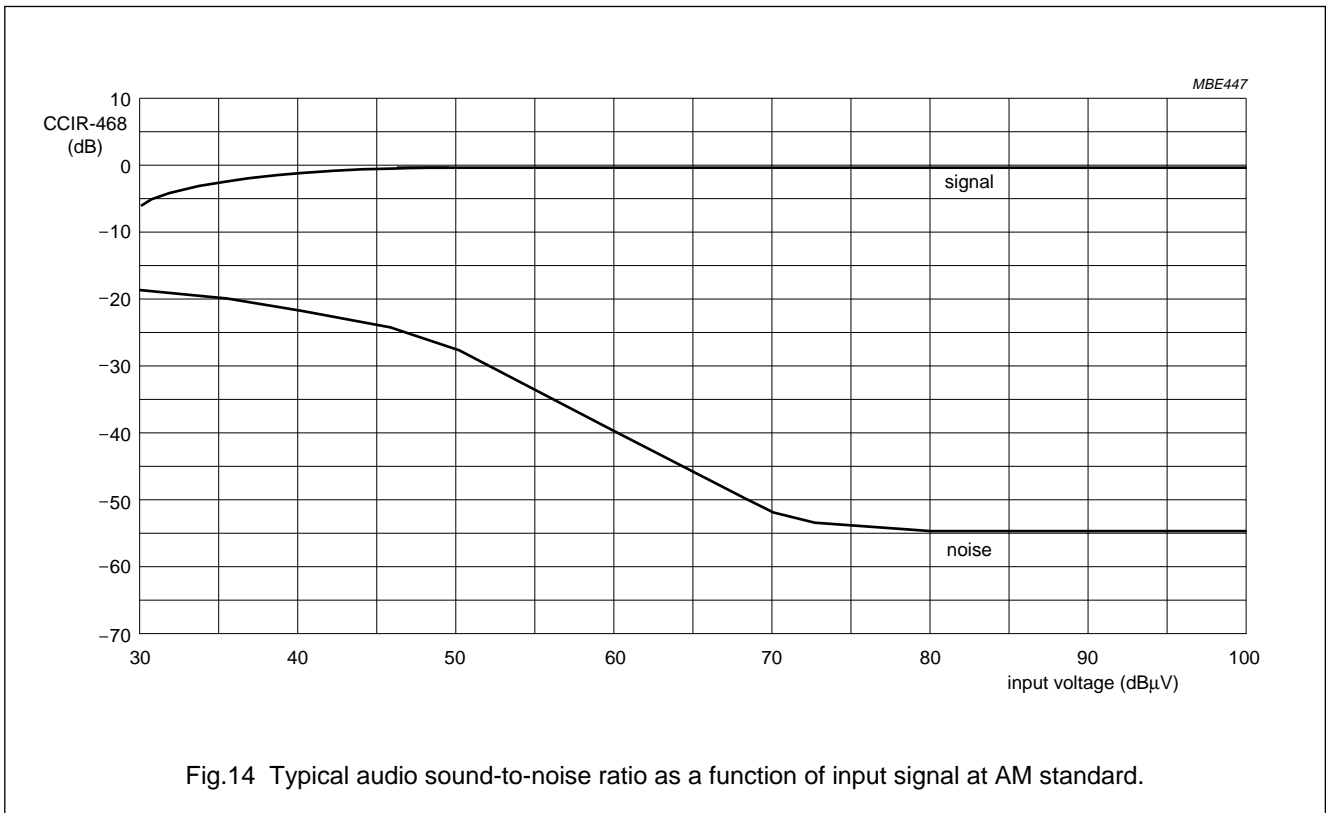

Fig.13 Typical video signal levels on output composite video (sound carrier OFF).

# Multistandard VIF-PLL and FM-PLL/AM demodulator

TDA9812





Multistandard VIF-PLL and  
FM-PLL/AM demodulator

TDA9812

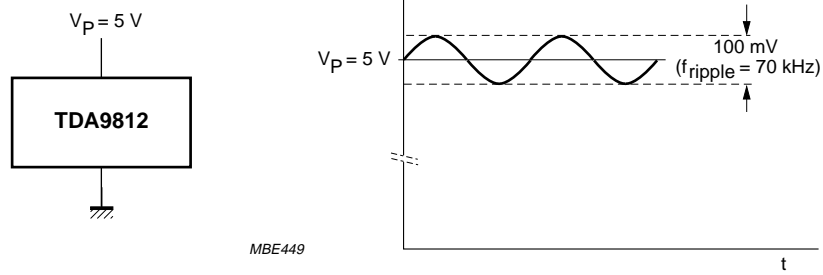

MBE449

Fig.16 Ripple rejection condition.

# Multistandard VIF-PLL and FM-PLL/AM demodulator

TDA9812

## INTERNAL CIRCUITRY

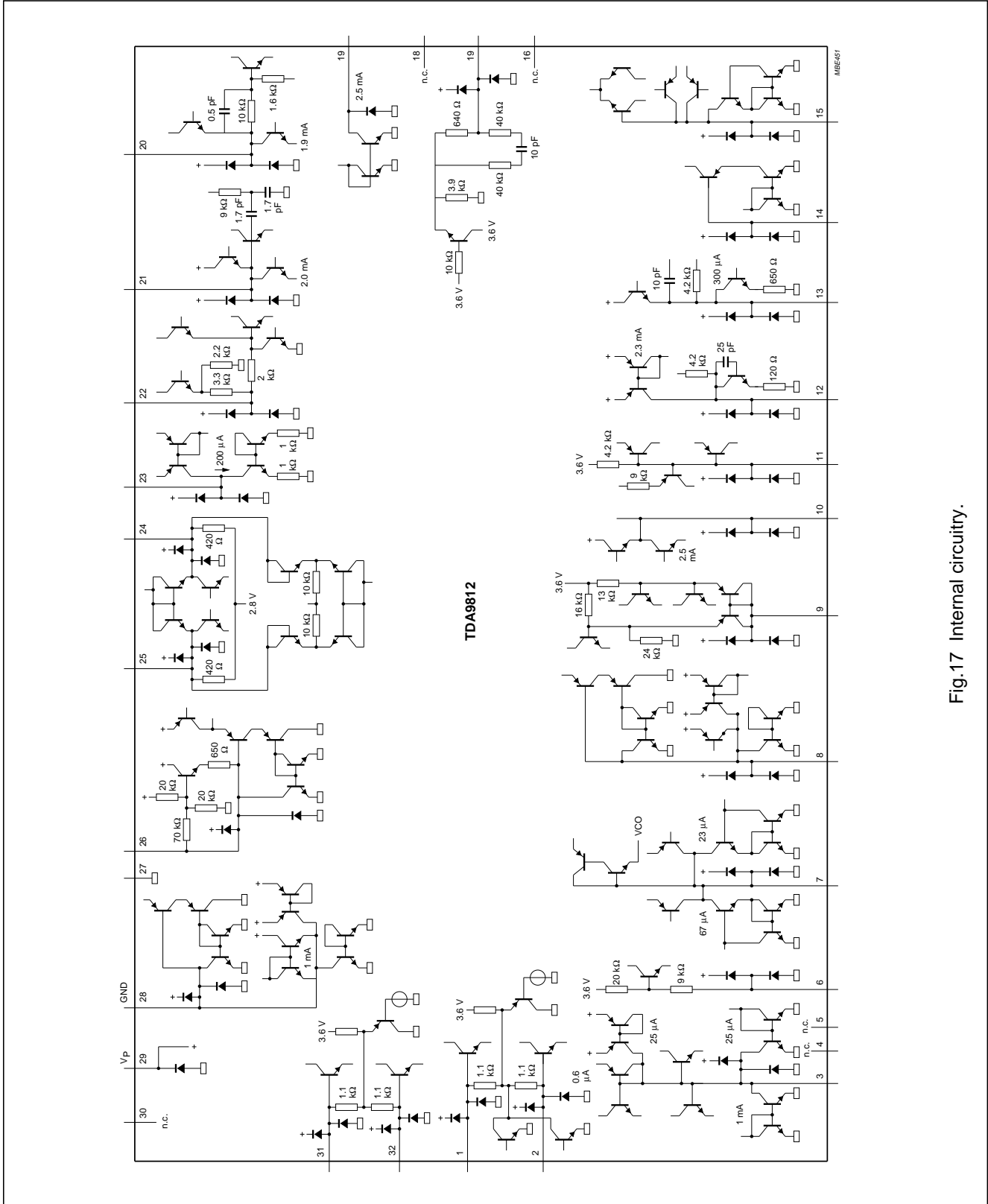
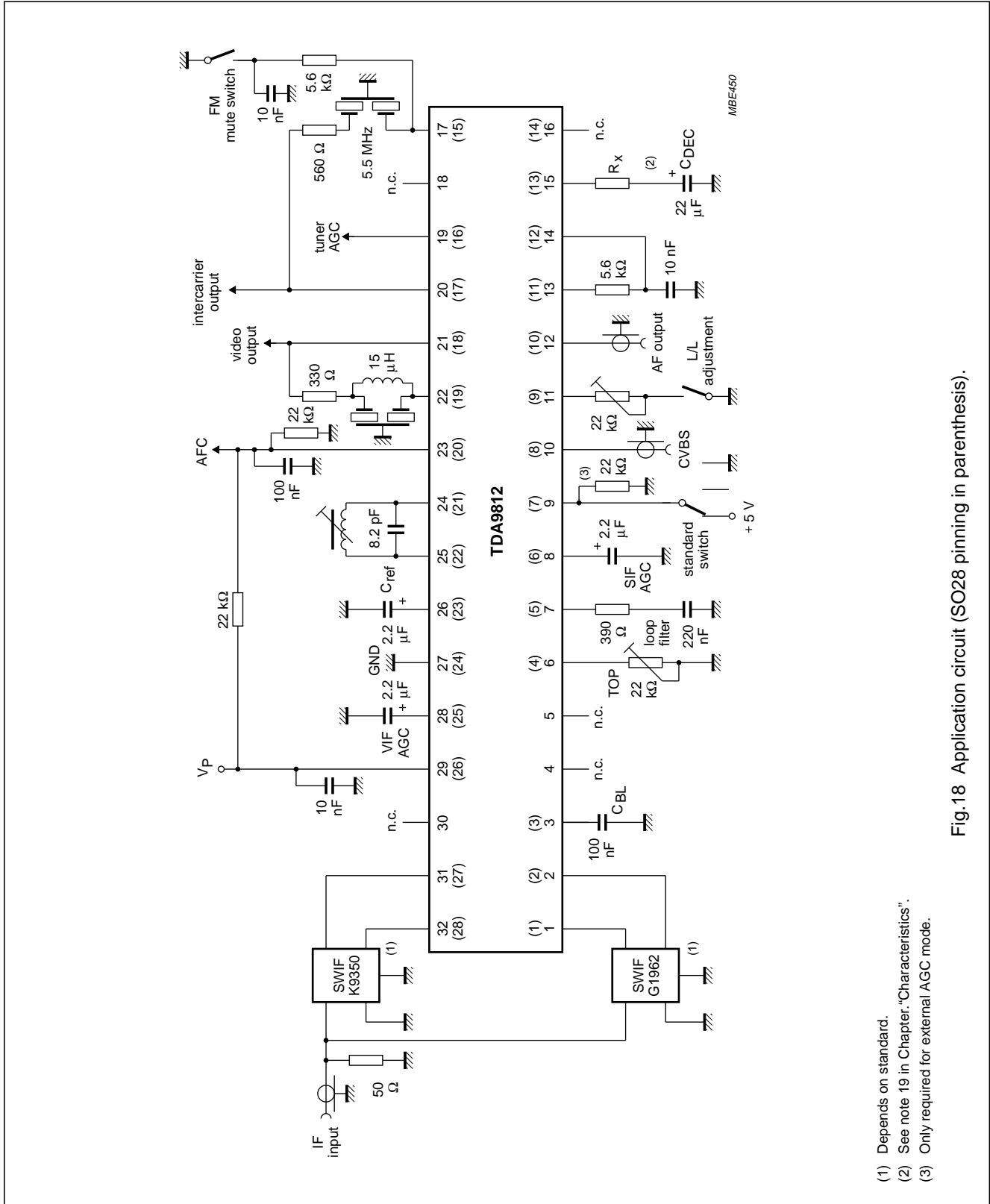

Fig.17 Internal circuitry.

Multistandard VIF-PLL and FM-PLL/AM demodulator

TDA9812

APPLICATION INFORMATION



- (1) Depends on standard.
- (2) See note 19 in Chapter "Characteristics".
- (3) Only required for external AGC mode.

Fig.18 Application circuit (SO28 pinning in parenthesis).

Multistandard VIF-PLL and FM-PLL/AM demodulator

TDA9812

PACKAGE OUTLINES

SDIP32: plastic shrink dual in-line package; 32 leads (400 mil)

SOT232-1

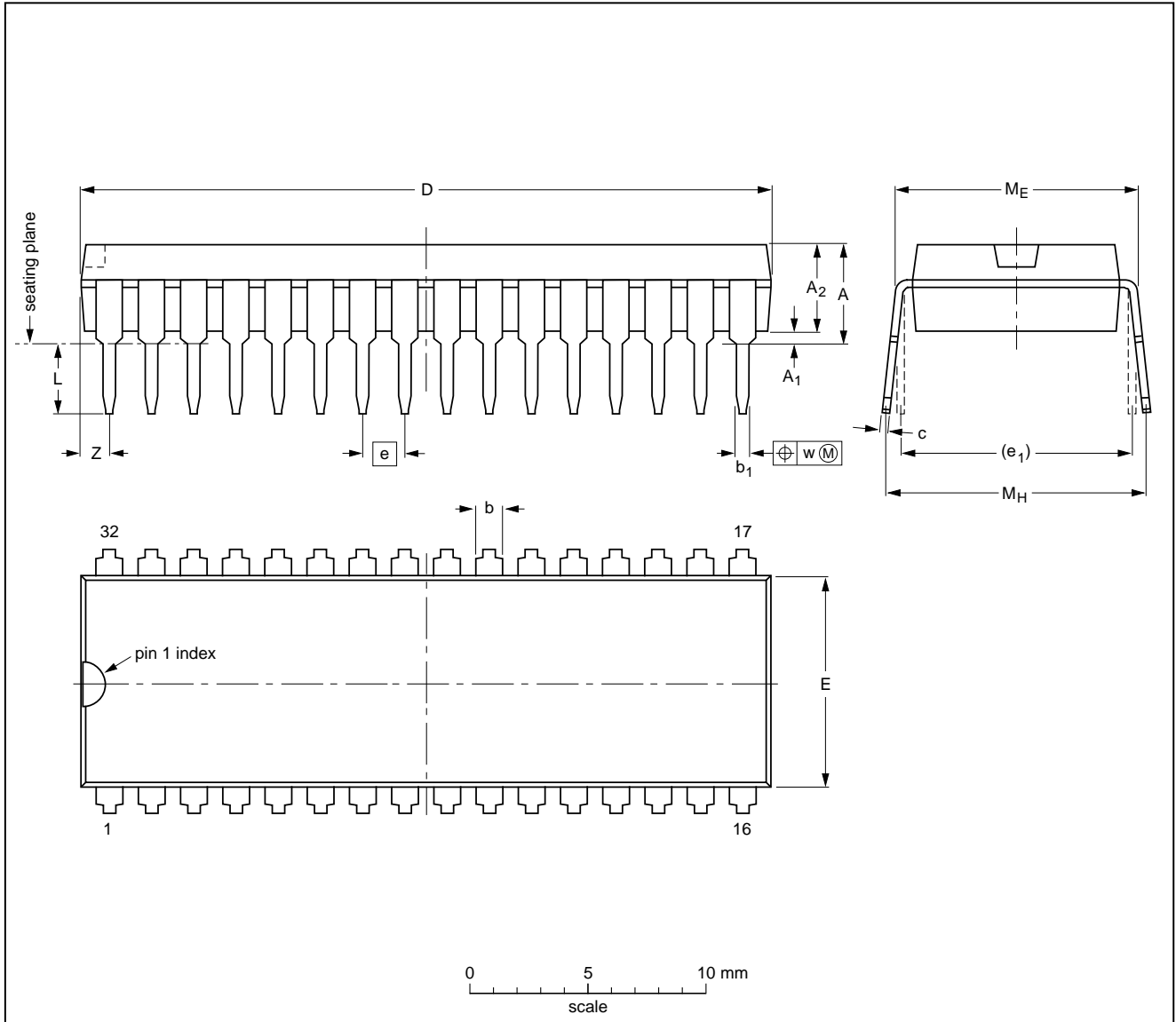

DIMENSIONS (mm are the original dimensions)

UNIT	A max.	A <sub>1</sub> min.	A <sub>2</sub> max.	b	b <sub>1</sub>	c	D <sup>(1)</sup>	E <sup>(1)</sup>	e	e <sub>1</sub>	L	M <sub>E</sub>	M <sub>H</sub>	w	z <sup>(1)</sup> max.
mm	4.7	0.51	3.8	1.3 0.8	0.53 0.40	0.32 0.23	29.4 28.5	9.1 8.7	1.778	10.16	3.2 2.8	10.7 10.2	12.2 10.5	0.18	1.6

Note

1. Plastic or metal protrusions of 0.25 mm maximum per side are not included.

OUTLINE VERSION	REFERENCES				EUROPEAN PROJECTION	ISSUE DATE
	IEC	JEDEC	EIAJ			
SOT232-1						92-11-17 95-02-04

Multistandard VIF-PLL and FM-PLL/AM demodulator

TDA9812

SO28: plastic small outline package; 28 leads; body width 7.5 mm

SOT136-1

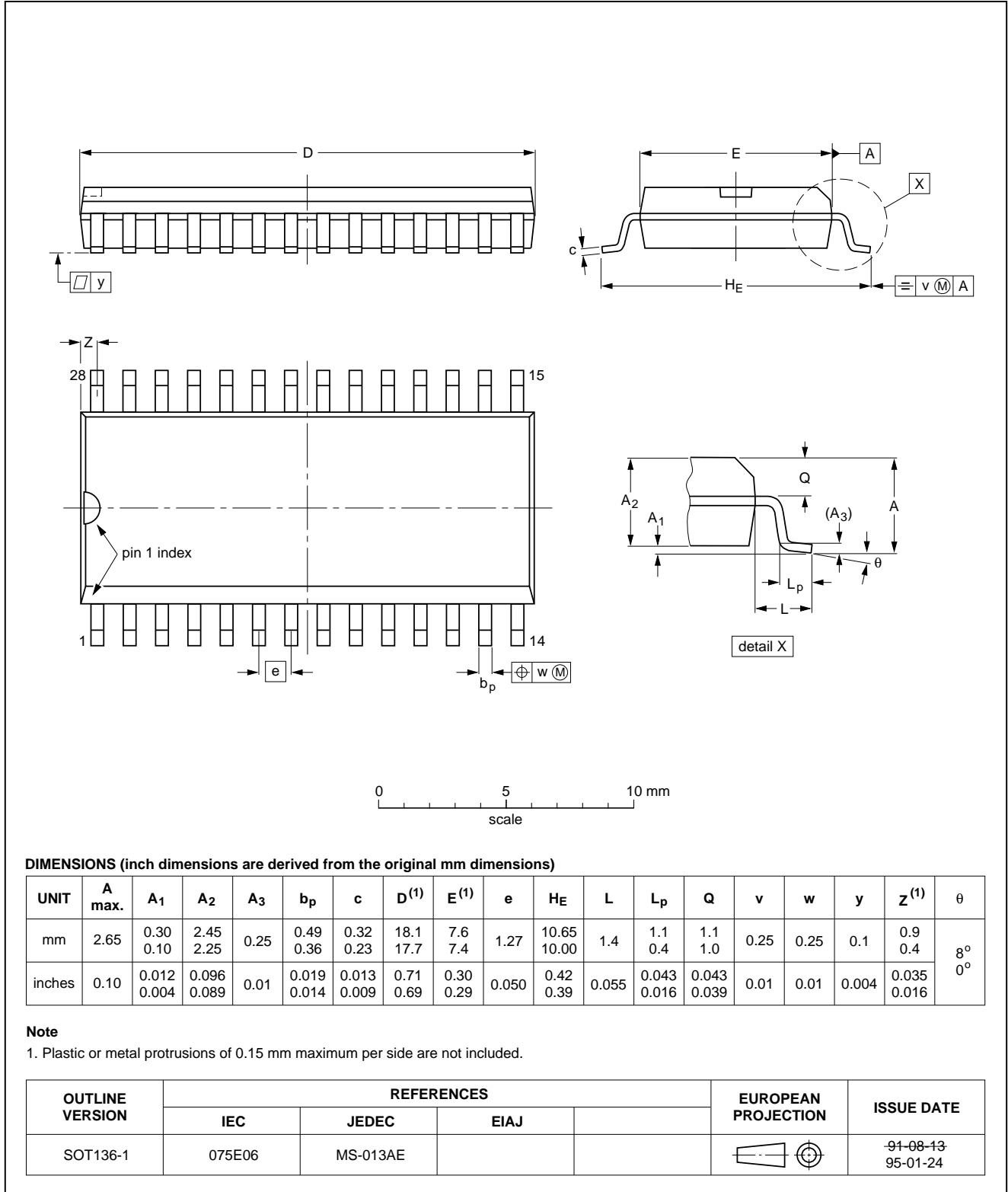

---

**Multistandard VIF-PLL and  
FM-PLL/AM demodulator**

---

**TDA9812****SOLDERING****Plastic dual in-line packages**

BY DIP OR WAVE

The maximum permissible temperature of the solder is 260 °C; this temperature must not be in contact with the joint for more than 5 s. The total contact time of successive solder waves must not exceed 5 s.

The device may be mounted up to the seating plane, but the temperature of the plastic body must not exceed the specified storage maximum. If the printed-circuit board has been pre-heated, forced cooling may be necessary immediately after soldering to keep the temperature within the permissible limit.

**REPAIRING SOLDERED JOINTS**

Apply a low voltage soldering iron below the seating plane (or not more than 2 mm above it). If its temperature is below 300 °C, it must not be in contact for more than 10 s; if between 300 and 400 °C, for not more than 5 s.

**Plastic small outline packages**

BY WAVE

During placement and before soldering, the component must be fixed with a droplet of adhesive. After curing the adhesive, the component can be soldered. The adhesive can be applied by screen printing, pin transfer or syringe dispensing.

Maximum permissible solder temperature is 260 °C, and maximum duration of package immersion in solder bath is 10 s, if allowed to cool to less than 150 °C within 6 s. Typical dwell time is 4 s at 250 °C.

A modified wave soldering technique is recommended using two solder waves (dual-wave), in which a turbulent wave with high upward pressure is followed by a smooth laminar wave. Using a mildly-activated flux eliminates the need for removal of corrosive residues in most applications.

**BY SOLDER PASTE REFLOW**

Reflow soldering requires the solder paste (a suspension of fine solder particles, flux and binding agent) to be applied to the substrate by screen printing, stencilling or pressure-syringe dispensing before device placement.

Several techniques exist for reflowing; for example, thermal conduction by heated belt, infrared, and vapour-phase reflow. Dwell times vary between 50 and 300 s according to method. Typical reflow temperatures range from 215 to 250 °C.

Preheating is necessary to dry the paste and evaporate the binding agent. Preheating duration: 45 min at 45 °C.

**REPAIRING SOLDERED JOINTS (BY HAND-HELD SOLDERING IRON OR PULSE-HEATED SOLDER TOOL)**

Fix the component by first soldering two, diagonally opposite, end pins. Apply the heating tool to the flat part of the pin only. Contact time must be limited to 10 s at up to 300 °C. When using proper tools, all other pins can be soldered in one operation within 2 to 5 s at between 270 and 320 °C. (Pulse-heated soldering is not recommended for SO packages.)

For pulse-heated solder tool (resistance) soldering of VSO packages, solder is applied to the substrate by dipping or by an extra thick tin/lead plating before package placement.

---

**Multistandard VIF-PLL and  
FM-PLL/AM demodulator**

---

TDA9812

**DEFINITIONS**

<b>Data sheet status</b>	
Objective specification	This data sheet contains target or goal specifications for product development.
Preliminary specification	This data sheet contains preliminary data; supplementary data may be published later.
Product specification	This data sheet contains final product specifications.
<b>Limiting values</b>	
Limiting values given are in accordance with the Absolute Maximum Rating System (IEC 134). Stress above one or more of the limiting values may cause permanent damage to the device. These are stress ratings only and operation of the device at these or at any other conditions above those given in the Characteristics sections of the specification is not implied. Exposure to limiting values for extended periods may affect device reliability.	
<b>Application information</b>	
Where application information is given, it is advisory and does not form part of the specification.	

**LIFE SUPPORT APPLICATIONS**

These products are not designed for use in life support appliances, devices, or systems where malfunction of these products can reasonably be expected to result in personal injury. Philips customers using or selling these products for use in such applications do so at their own risk and agree to fully indemnify Philips for any damages resulting from such improper use or sale.