

The Data Book Project

DatasheetArchive.com has launched an ambitious effort to digitize thousands of obsolete data books and technical manuals, making them searchable via the DatasheetArchive website.

Scroll down to see the scanned document.

FOR MAINTENANCE PURPOSES ONLY: DO NOT USE FOR NEW DESIGNS

TBA530

RGB MATRIX PRE-AMPLIFIER

The TBA530 is an integrated R-G-B matrix pre-amplifier for colour television receivers incorporating a matrix pre-amplifier for R-G-B cathode or grid drive of the picture tube without clamping circuits. The chip layout has been designed to ensure tight thermal coupling between all transistors in each channel to minimise thermal drifts between channels. Also, each channel follows an identical layout to ensure equal frequency behaviour of the three channels.

This integrated circuit has been designed to be driven from the TBA520 synchronous demodulator integrated circuit.

ABSOLUTE MAXIMUM RATINGS

Supply voltage, V_{CC}	13.2V
Supply currents:—	
$I_1 = I_{11} = I_{14} \text{ max}$	10mA
$I_{10} = I_{13} = I_{16} \text{ max}$	50mA*
Total power dissipation at $T_{amb} = 60^\circ\text{C}$, P_{TOT}	400mW*
Storage temperature	-55 to $+125^\circ\text{C}$
Operating ambient temperature	-10 to $+60^\circ\text{C}$

At increased voltages due to external failures (e.g., collector-base breakdown in the output transistors) a maximum current of 50mA is permitted between pins 16 and 8, 13 and 8, 10 and 8. The maximum permissible power dissipation is then 500mW.

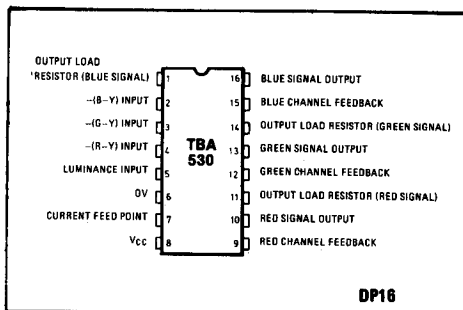

Fig. 1 Pin connections

QUICK REFERENCE DATA

■ Supply Voltage (Nominal)	12V
■ Total Supply Current (Nominal)	30mA
■ Operating Ambient Temperature Range	-10 to $+60^\circ\text{C}$
■ Gain of Luminance and Colour-difference Channels (Typ.)	100

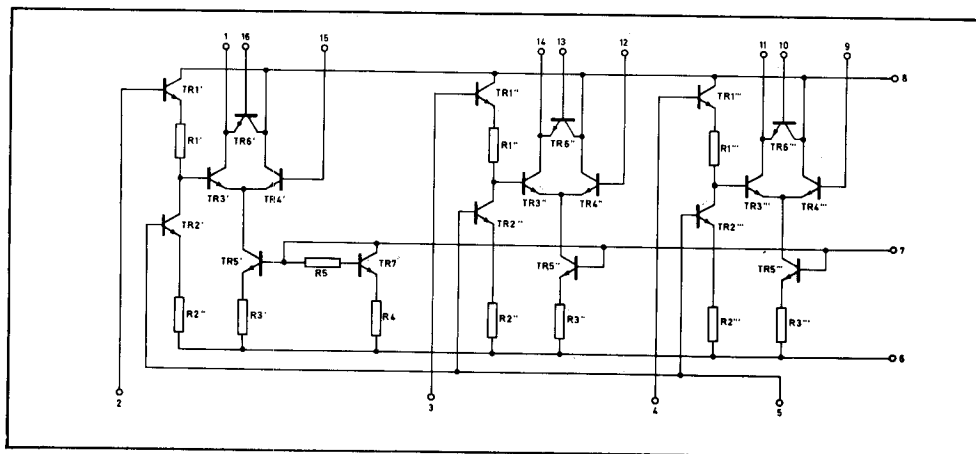

Fig. 2 TBA530 circuit diagram

ELECTRICAL CHARACTERISTICS

Test conditions (unless otherwise stated):-

$V_{CC} = +12V, T_{amb} = +25^{\circ}C$

Black level: $V_{R-Y} = V_{G-Y} = V_{B-Y} = 7.5V$

$V_Y = 1.5V$

Reference = pin 6

Characteristic	Symbol	Value			Units	Conditions
		Min.	Typ.	Max.		
Gain of colour channels (B-Y, G-Y, R-Y)	G ₂		100		-	f = 0.5MHz (see note 1)
	G ₃		100		-	
	G ₄		100		-	
Ratio of gain of luminance amplifier to colour amplifiers DC output voltages	V _R	0.9	140	1.1	-	See note 2
	V _G		140		V	
	V _B		140		V	
Input resistance of colour difference amplifiers	R ₂		60		kΩ	f = 1kHz
	R ₃		60		kΩ	
	R ₄		60		kΩ	
Input capacitance of colour difference amplifiers	C ₂		3		pF	f = 1MHz
	C ₃		3		pF	
	C ₄		3		pF	
Input resistance of luminance amplifier	R ₅		20		kΩ	f = 1kHz
Input capacitance of luminance amplifier	C ₅		10		pF	f = 1MHz
3dB bandwidth of all channels	B		6		MHz	
Total current drain	I _{TOT}		30		mA	

NOTES

1. G is defined as the voltage ratio between the input signals at the pins 2, 3, 4 and the output signals at the collectors of the output transistors.
2. At the collectors of the output transistors. The value of this voltage is also dependent on the external circuitry.

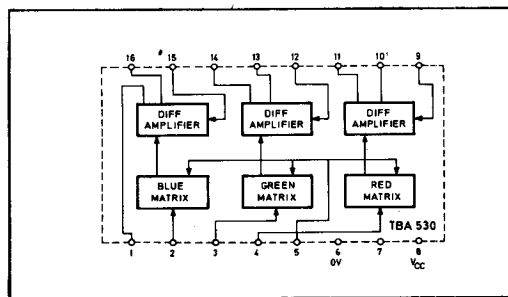

Fig.3 TBA530 block diagram

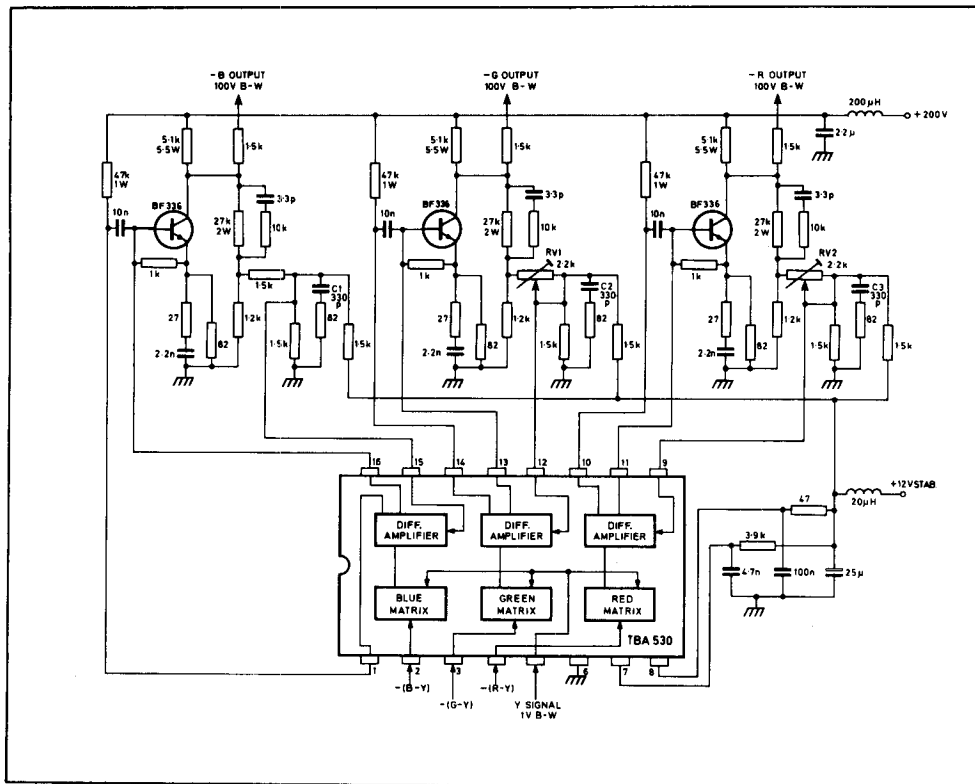

Fig. 4 Typical application diagram

FUNCTIONAL DESCRIPTION

Pin

1. Output load resistor, blue signal
(Also pins 11 and 14 for red and green signals respectively.) Resistors (47k Ω , 1W) connected to +200V provide the high value loads for the internal amplifying stages. The nominal operating potential on these pins is defined by the IC and the DC feedback and is approximately +8V. The maximum current which can be allowed at each of these pins is 10mA.
2. -(B-Y) input signal
This signal is fed via a low-pass filter from the TBA520 demodulator IC (pin 7) having a DC level of about +7.5V. The input resistance for this pin is typically 60k Ω with an input capacitance of less than 5pF (similarly for pins 3 and 4).
3. -(G-Y) input signal
The DC black level of this signal is about +7.5V. (See pin 2.)
4. -(R-Y) input signal
The DC black level of this signal is about +7.5V. (See pin 2.)
5. Luminance signal input
The DC level on this pin for picture black is +1.6V. The required signal amplitude is 1V black-to-white with negative-going syncs (or blanking) for cathode drive as shown. The input resistance at this pin is 20k Ω approximately with a capacitance of less than 15pF.
6. Negative supply (earth).
7. Current feed point
A current of approximately 2.5mA is required at this pin, fed via a 3.9k Ω resistor from +12V, to bias the internal differential amplifiers. A decoupling capacitor of 4.7nF is necessary.
8. Positive 12V supply
Maximum supply voltage permitted, 13.2V. Current consumption approximately 30mA.
9. Red channel feedback (green channel, pin 12; blue channel, pin 15)
The DC working points and gains of both the output stages and the IC amplifier stages are stabilised by the feedback circuits. The black level potentials at the collectors of the output stages (tube cut-off) are adjusted by setting correctly the DC levels of the colour difference signals produced by the TBA520 demodulator IC. The gains of the R-G-B output stages are adjusted to give the correct white points setting on the picture tube by adjusting the potentiometers in the feedback paths (RV1, RV2).

10. Red signal output (green and blue signal outputs on 13 and 16)

These pins are internally connected with pins 11, 14 and 1 respectively via zener type junctions to give a DC level shift appropriate for driving the output transistor bases directly. To by-pass the Zener junctions at HF three 10nF capacitors are required.

11. Output load resistor, red channel (see pin 1).
12. Green channel feedback (see pin 9).
13. Green signal output (see pin 10).
14. Output load resistors, green channel (see pin 1).
15. Blue channel feedback (see pin 9).
16. Blue signal output (see pin 10).

OPERATING NOTES

Careful attention to earth paths should be given, avoiding common impedances between the input (decoder) side and the output stages. Also, to enable matched performance to be achieved, a symmetrical board and component layout should be adopted for the three output stages. To compensate for the effect upon HF response of inevitable differences the compensating capacitors C₁ and C₂ and C₃ may be appropriately selected for any given board layout.

The signal black level at the collectors of the R-G-B output stages depends upon the +12V supply, the DC level of the colour difference signals from the TBA520 demodulator IC and the black level potential of the luminance signal applied to the TBA530 matrix IC. The DC levels of the signals produced and handled by the IC's are designed to have approximately proportional tracking with the 12V supply potential,

$$\text{i.e., } \frac{\Delta V (\text{DC level, signal})}{\Delta V 12V} \approx \frac{V_{\text{nom}} (\text{DC level, signal})}{12}$$

To ensure that changes in picture black level due to variations on the 12V supply to the IC's occur in a predictable way, all the IC's should be operated from a common supply line. This is specially important for the TBA520 and TBA530. Furthermore, to limit the changes in picture black level during receiver operation, the 12V supply should have a stability of not worse than $\pm 3\%$ due to operational variations.

To reduce the possibility of patterning on the picture due to radiation of the harmonics of the products of the demodulation process, the leads carrying the drive signals to the picture tube should be as short as the receiver layout will allow. Resistors (typically 1.5k Ω connected in series with the leads and mounted close to the collectors of the output transistors provide useful additional filtering of harmonics.